



BANKSY Display

Contents

[Safety and usage cautions](#)

[Mounting](#)

[Wiring Instructions](#)

[Wiring of position and direction inputs](#)

[Service Messages](#)

[Datasheet](#)

[Download](#)



✔ Updated to EN81-28:2018 regulation.

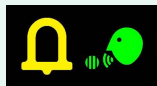

Safety and usage cautions

Before installing our products, we recommend you to consult the section about safety and usage cautions at the link below.



Mounting

⊖ DB1 – With D1 Screen (frontal mounting)

Frontal mounted on 0,7/3 mm pushbutton panel

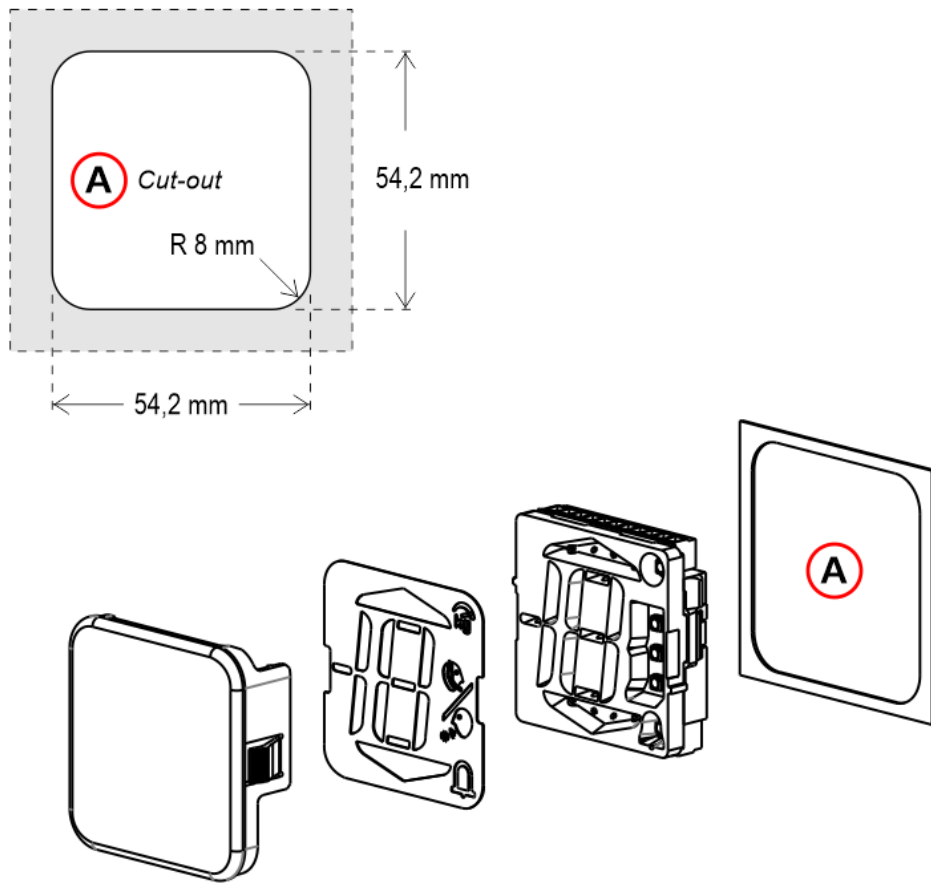

A) – Cut-out – Compatible with DMG D1 series displays

DB2 – (frontal mounting)

Frontal mounted on 0,7/3 mm pushbutton panel

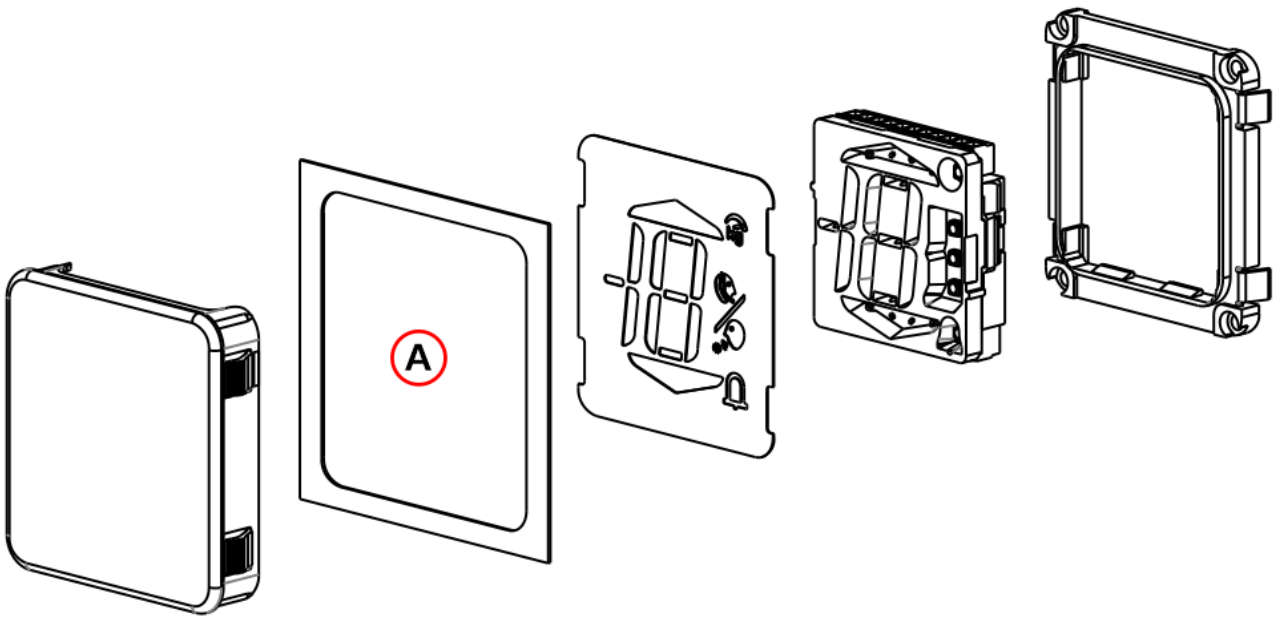
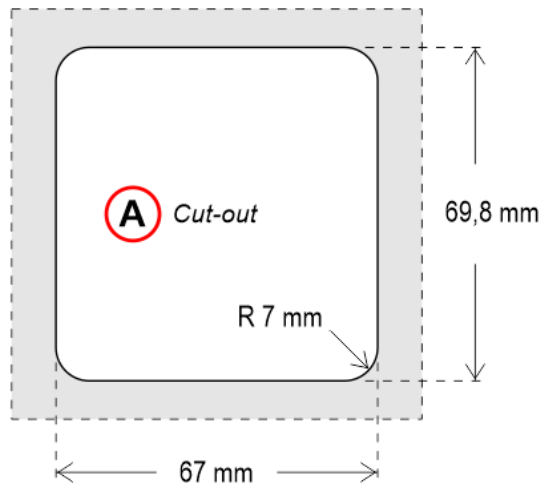

DB3 – (frontal mounting)

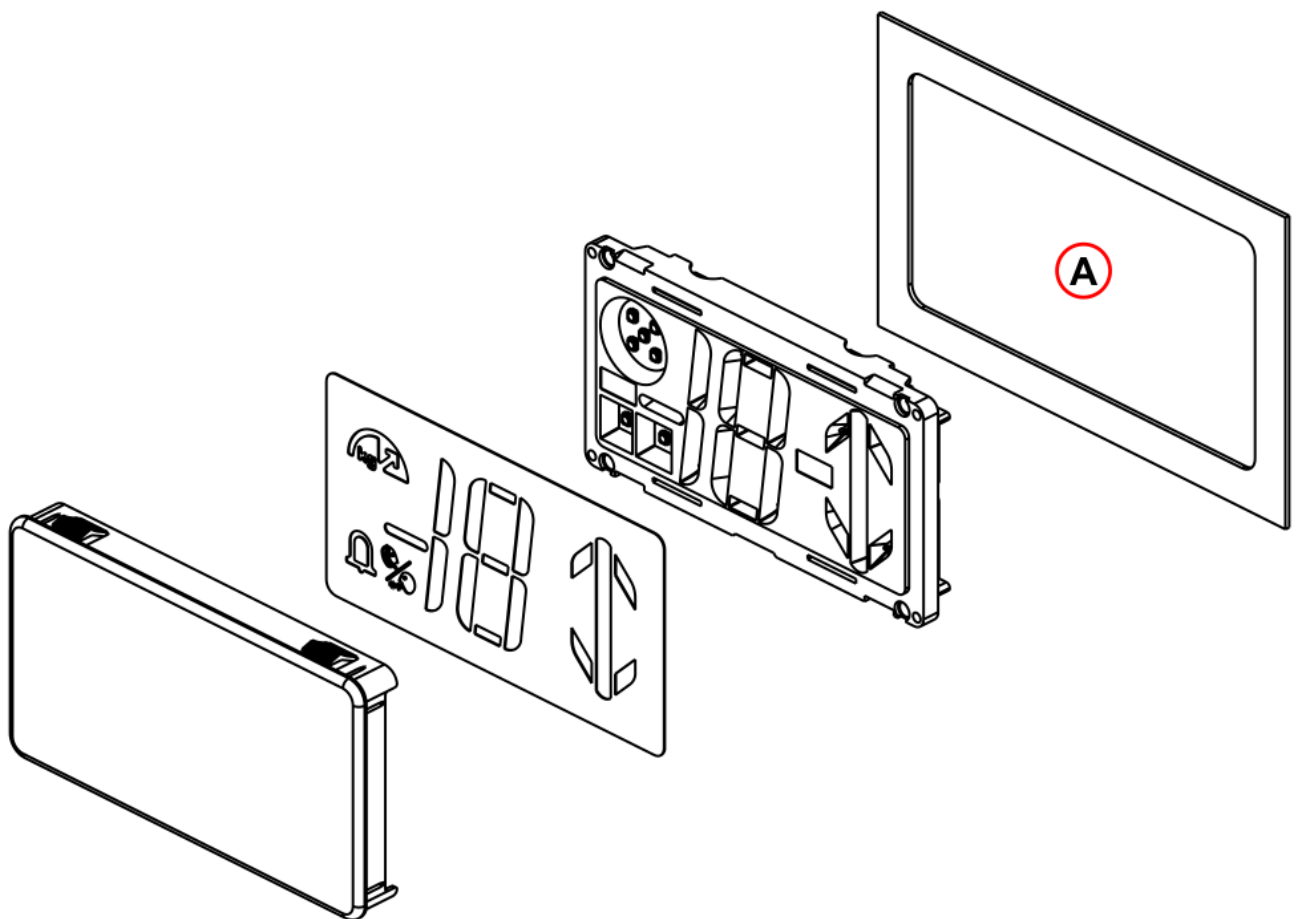
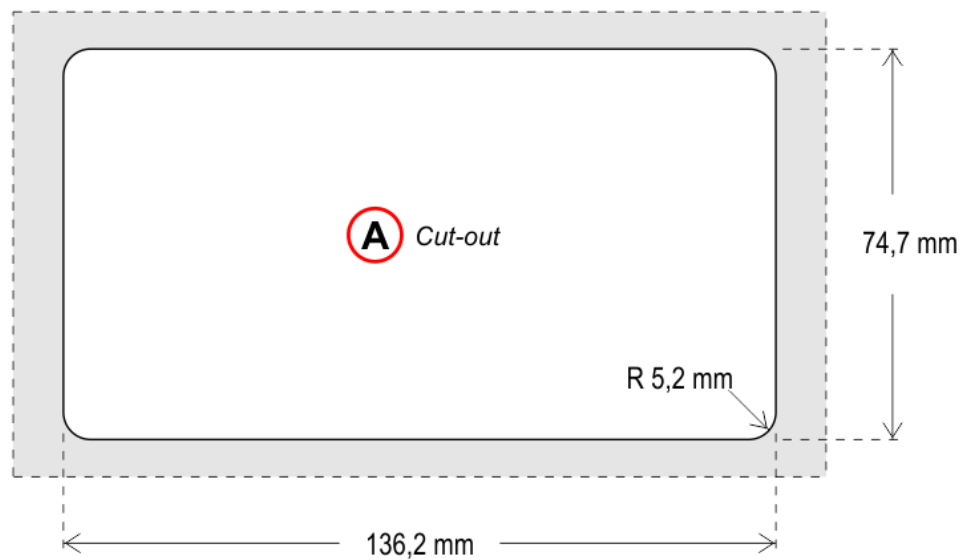

Wiring Instructions

Wiring of position and direction inputs

DMG

3-wires serial

DB1/DB2

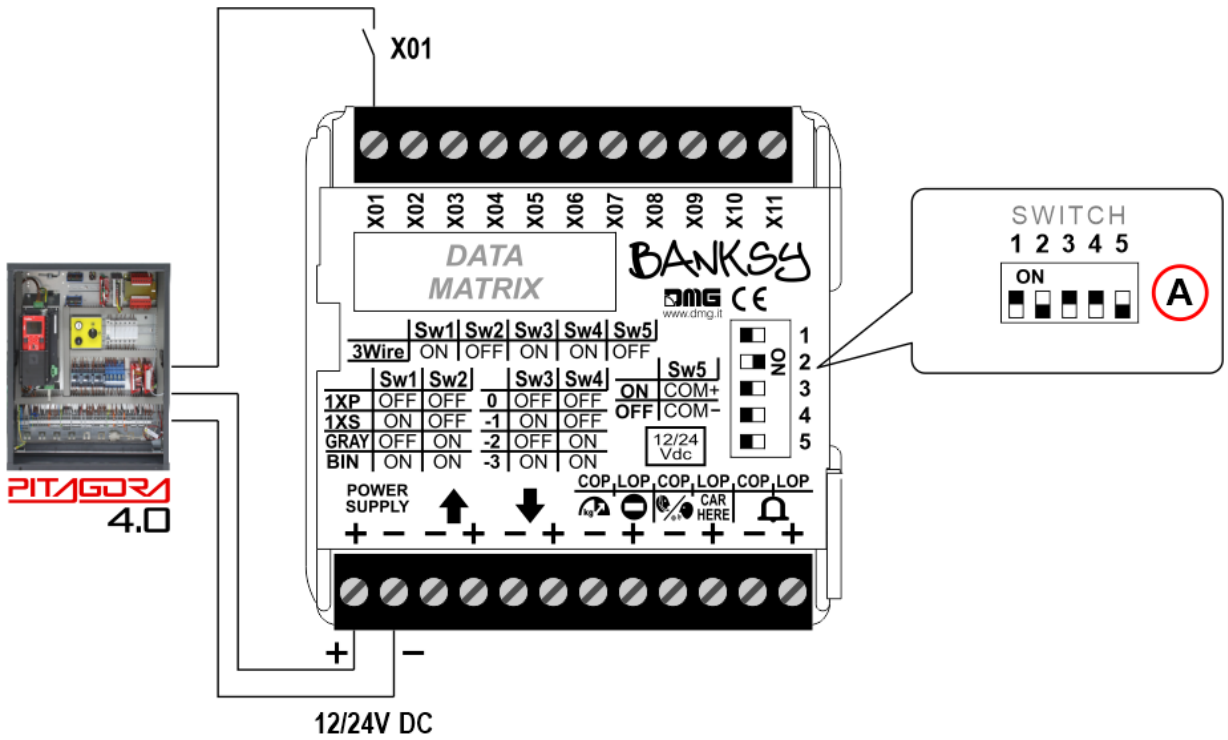

DB3

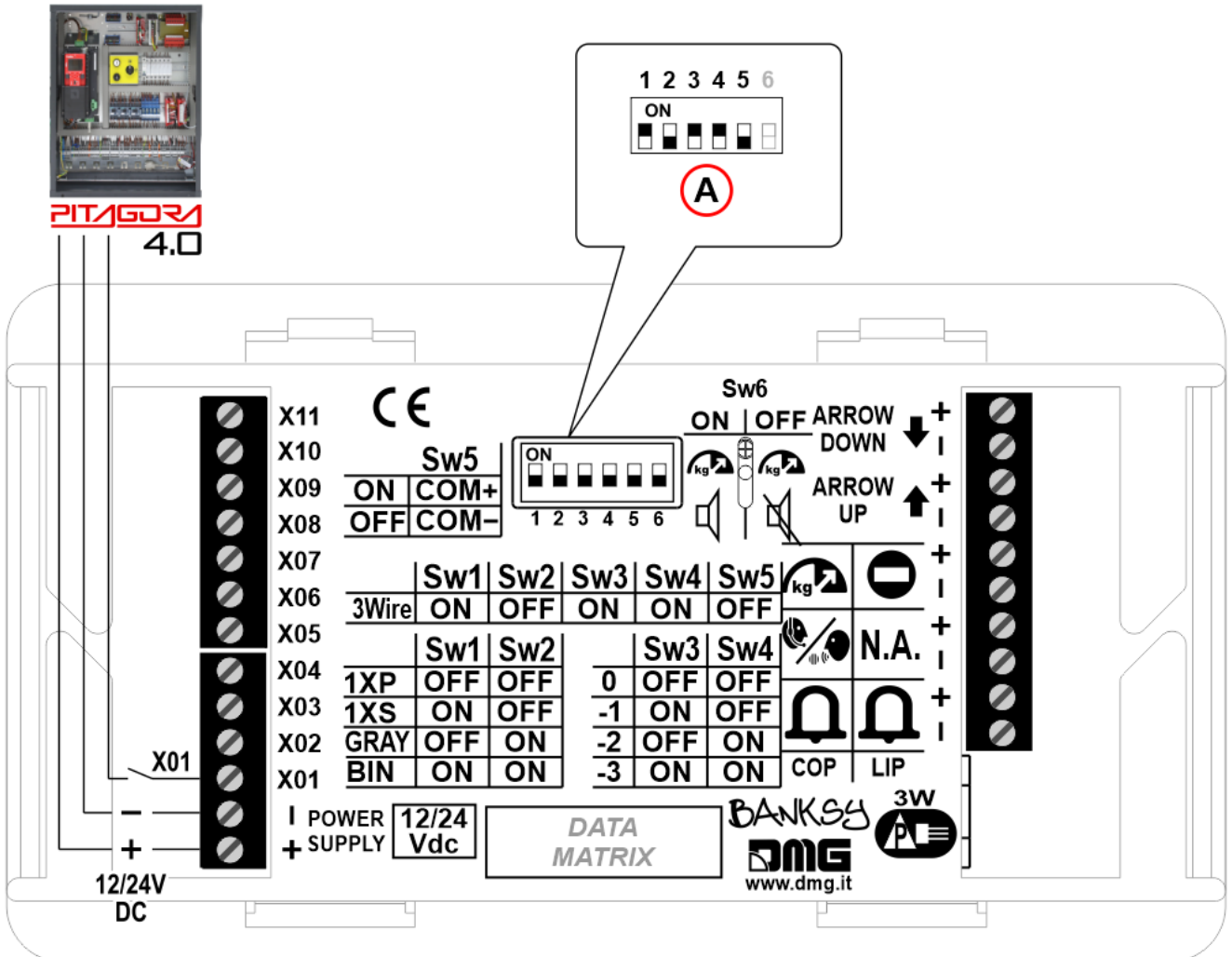

A) – Coding

3-wires serial (pre-wiring with JST)

DB3

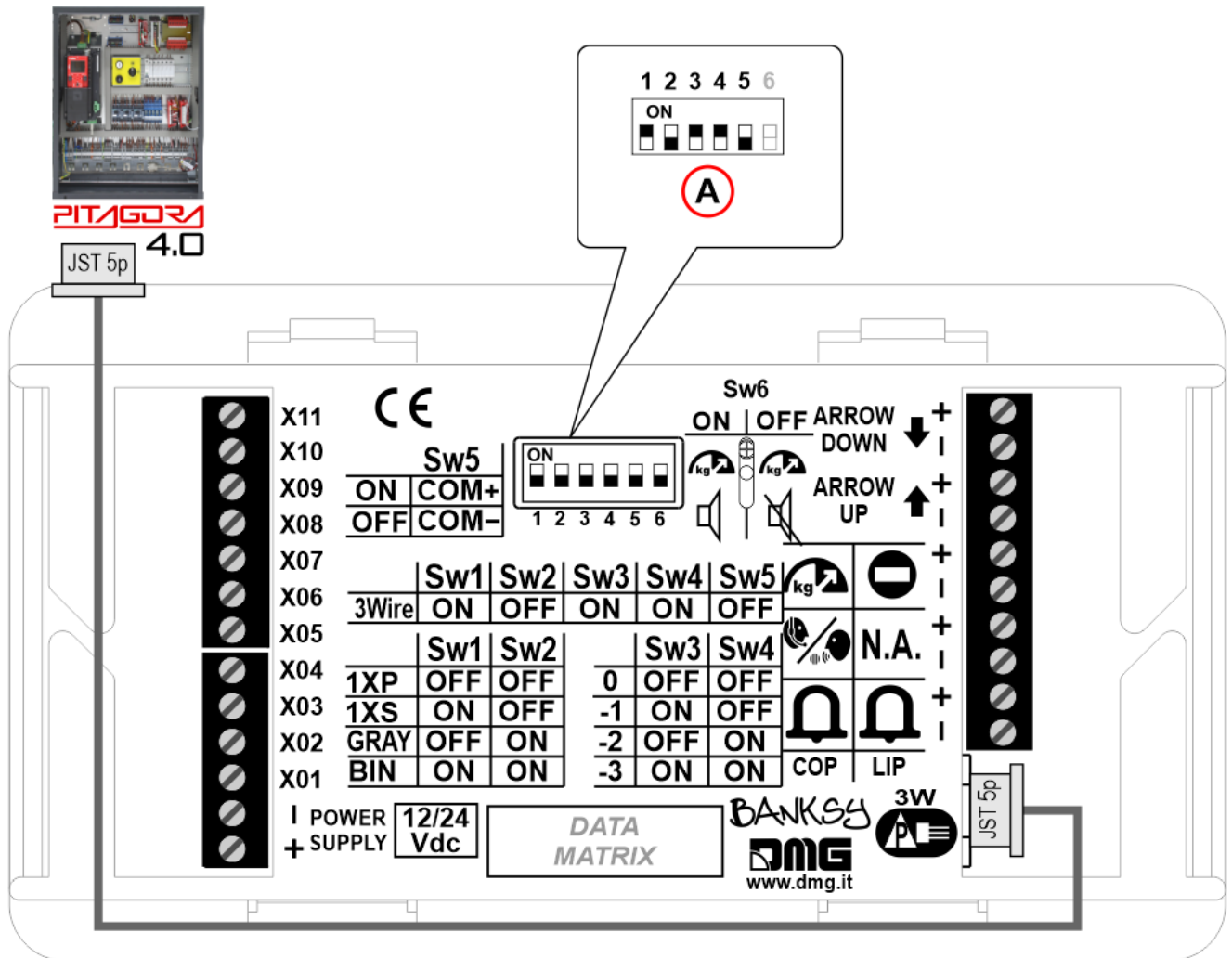

A) – Coding



29 floors max. (-9, 0, 19)

Encoder DEUM



For more details please refer to the [Encoder DEUM](#) support page.

DMG

3-wires serial

DB1/DB2

Encoder DEUM.M15CAN

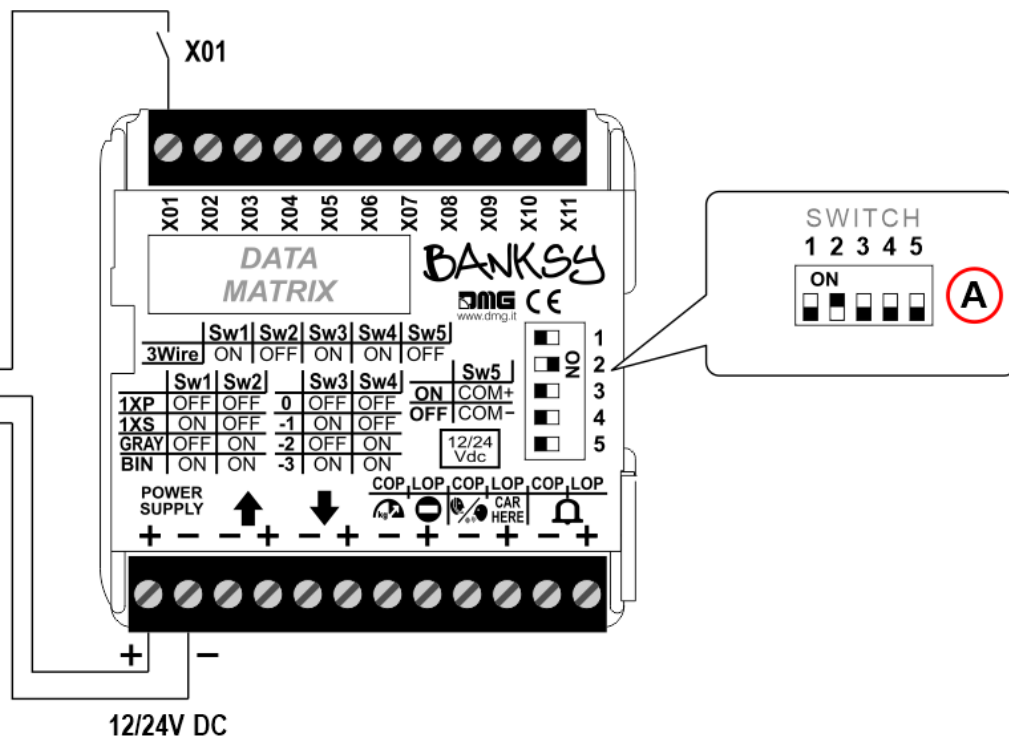

DB3

Encoder DEUM.M15CAN

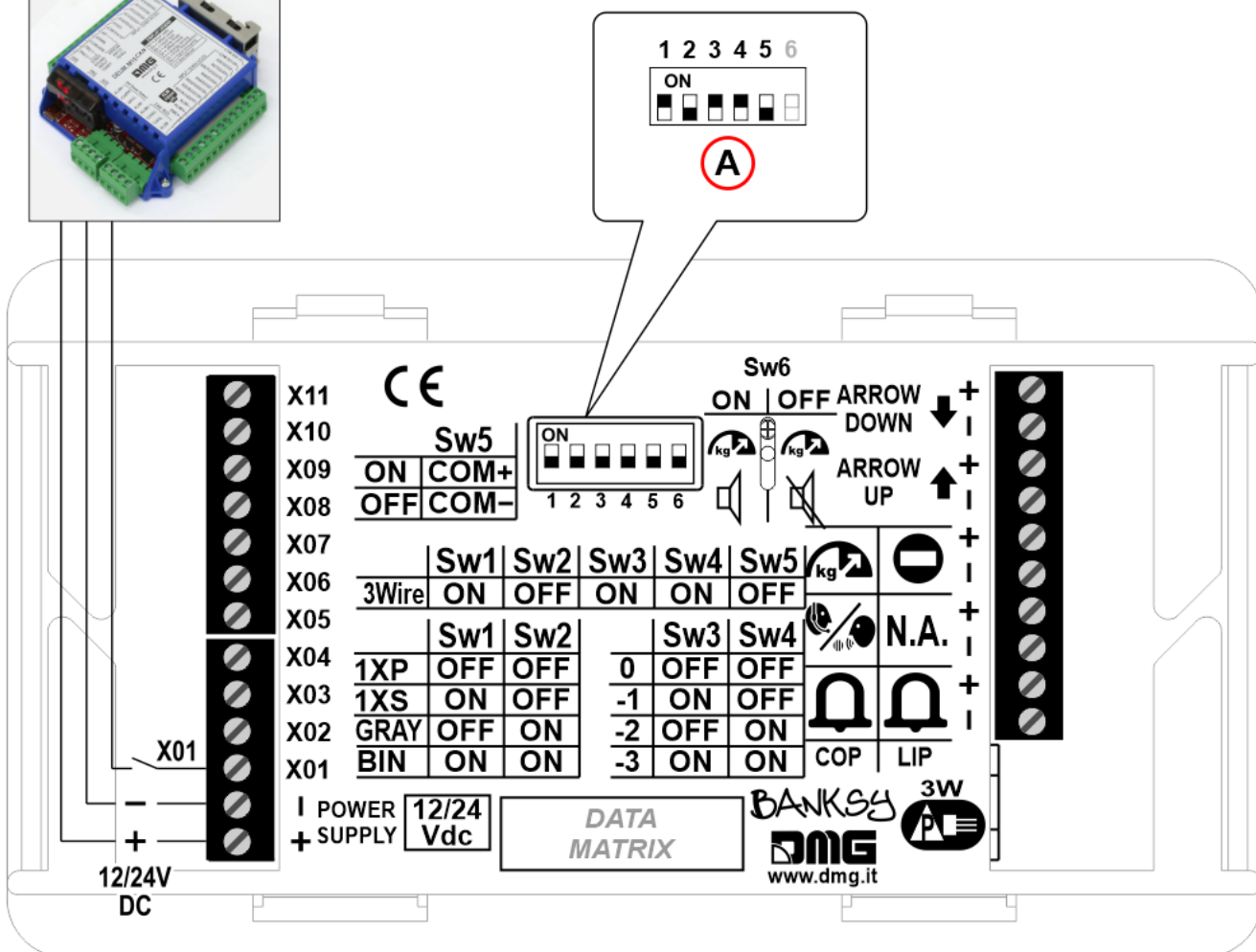

A) – Coding



29 floors max. (-9, 0, 19)

Other Controllers

1 Wire / Floor

DB1/DB2

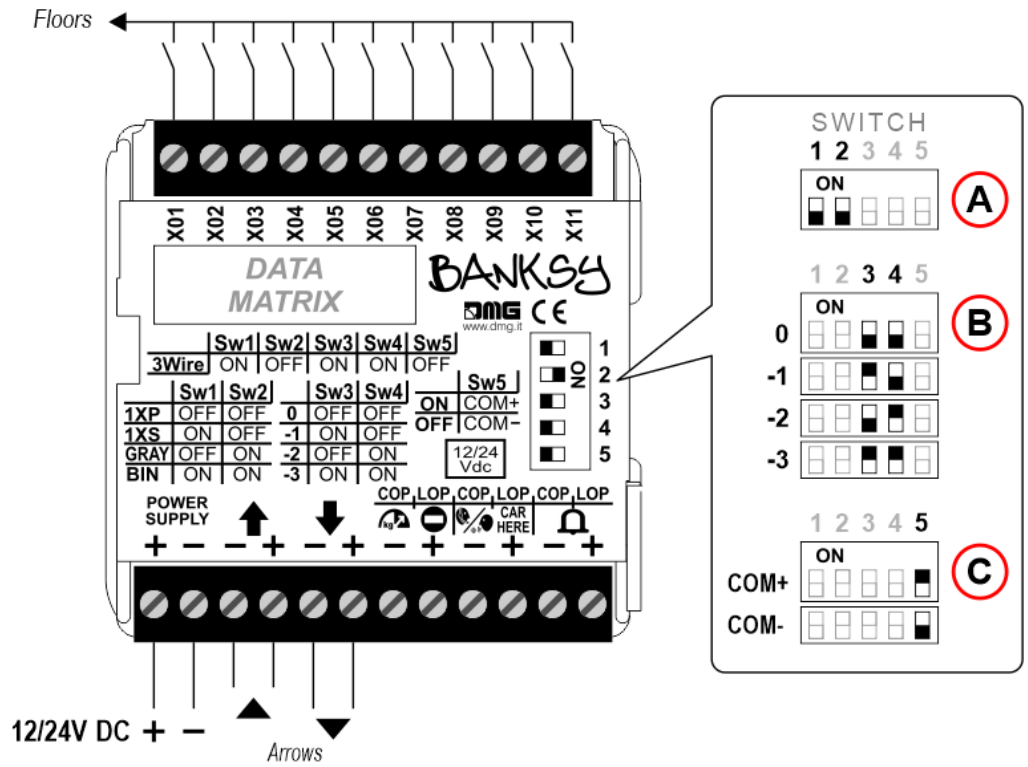

DB3

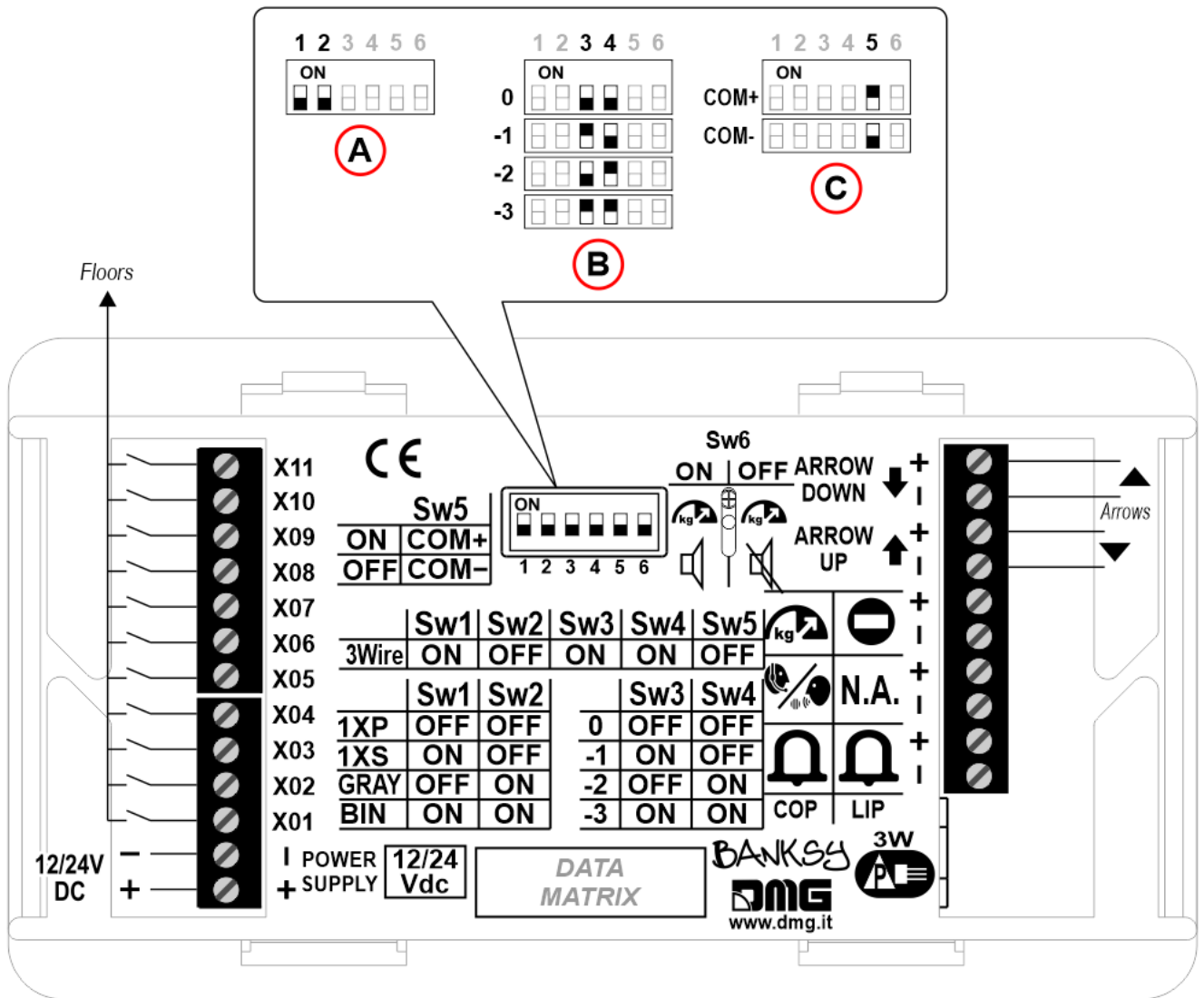

- A) – Coding
- B) – Offset (-3 ÷ 0)
- C) – Common (Inputs)



11 floors max.

1 Wire / Segment
DB1/DB2

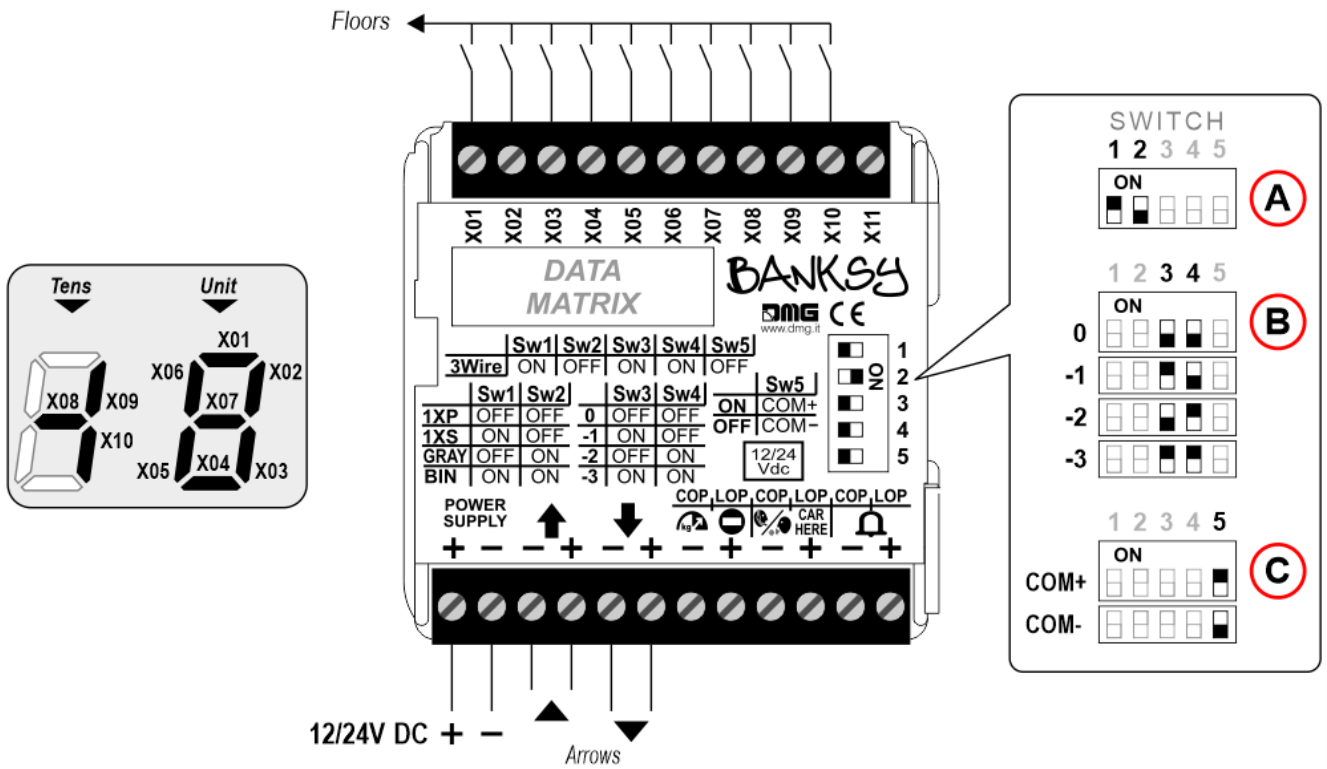

DB3

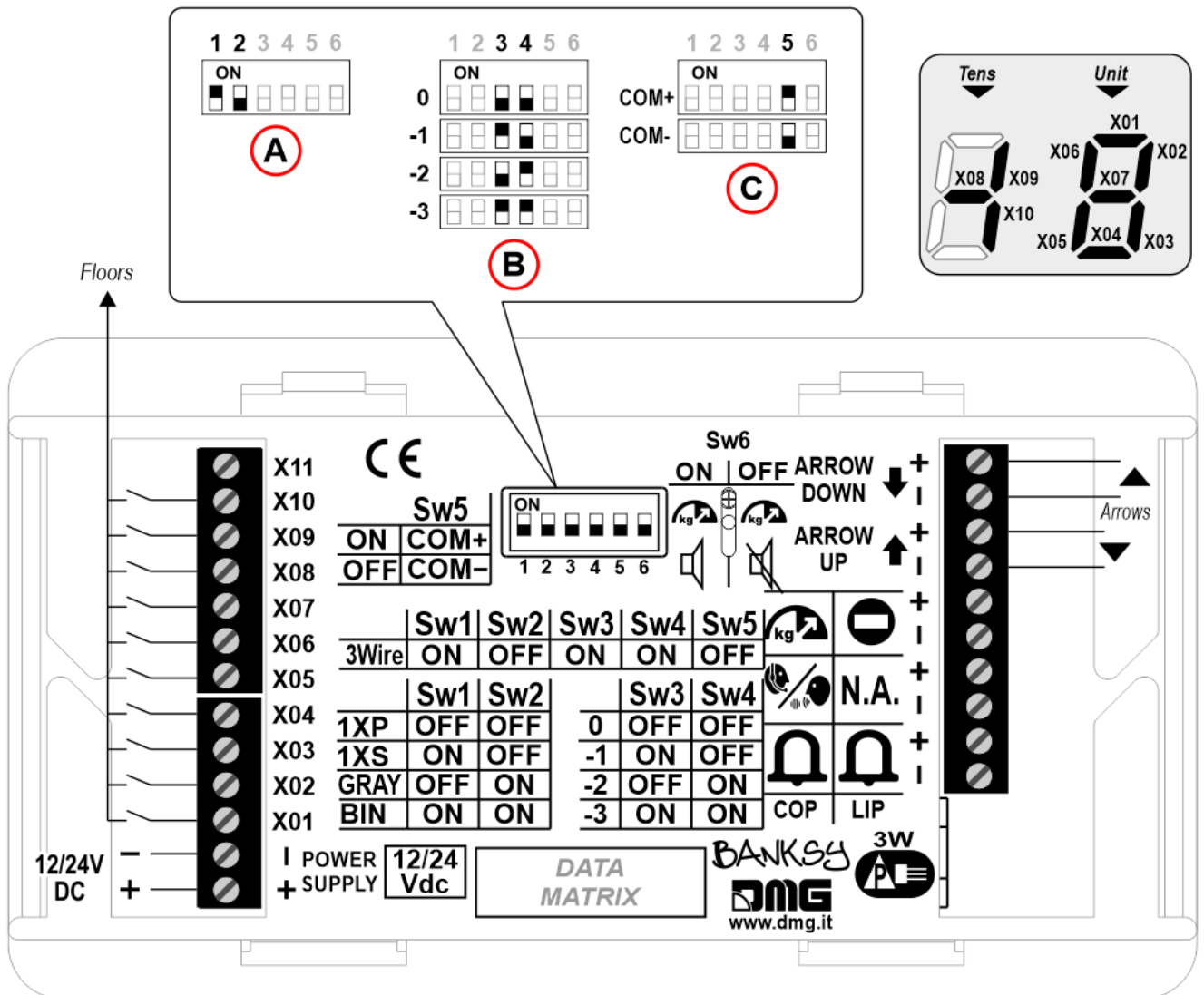

A) – Coding

B) – Offset (don't use the dip-switch to set the offset)

C) – Common (Inputs)



29 floors max. (-9, 0, 19)

Gray

DB1/DB2

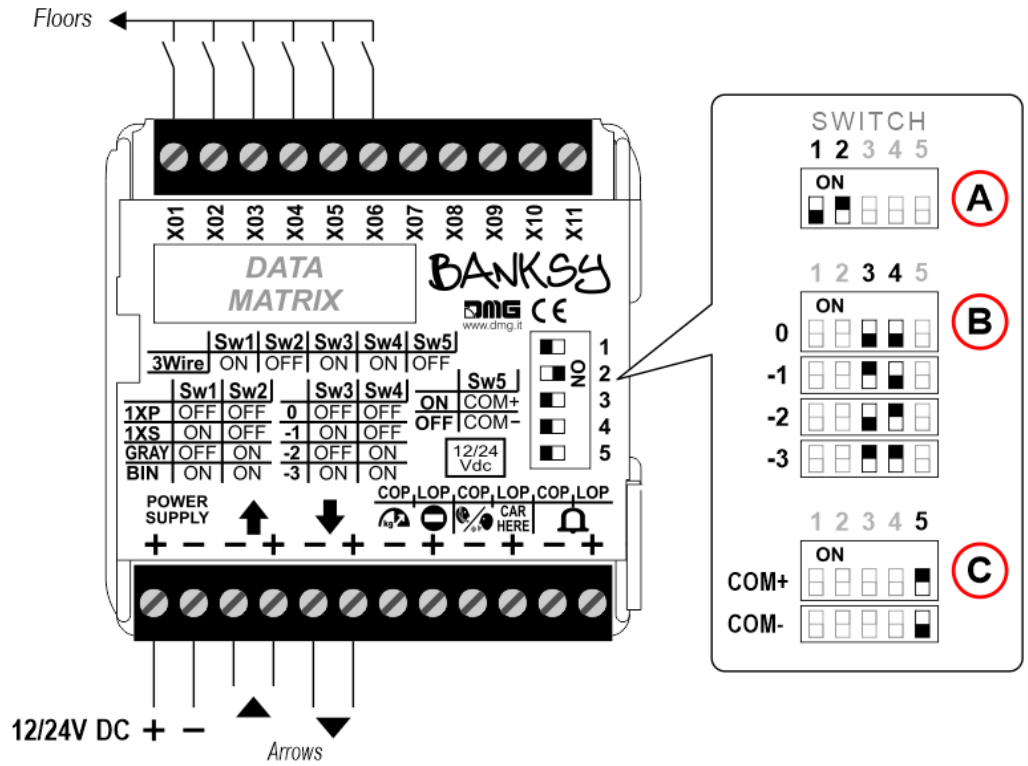

DB3

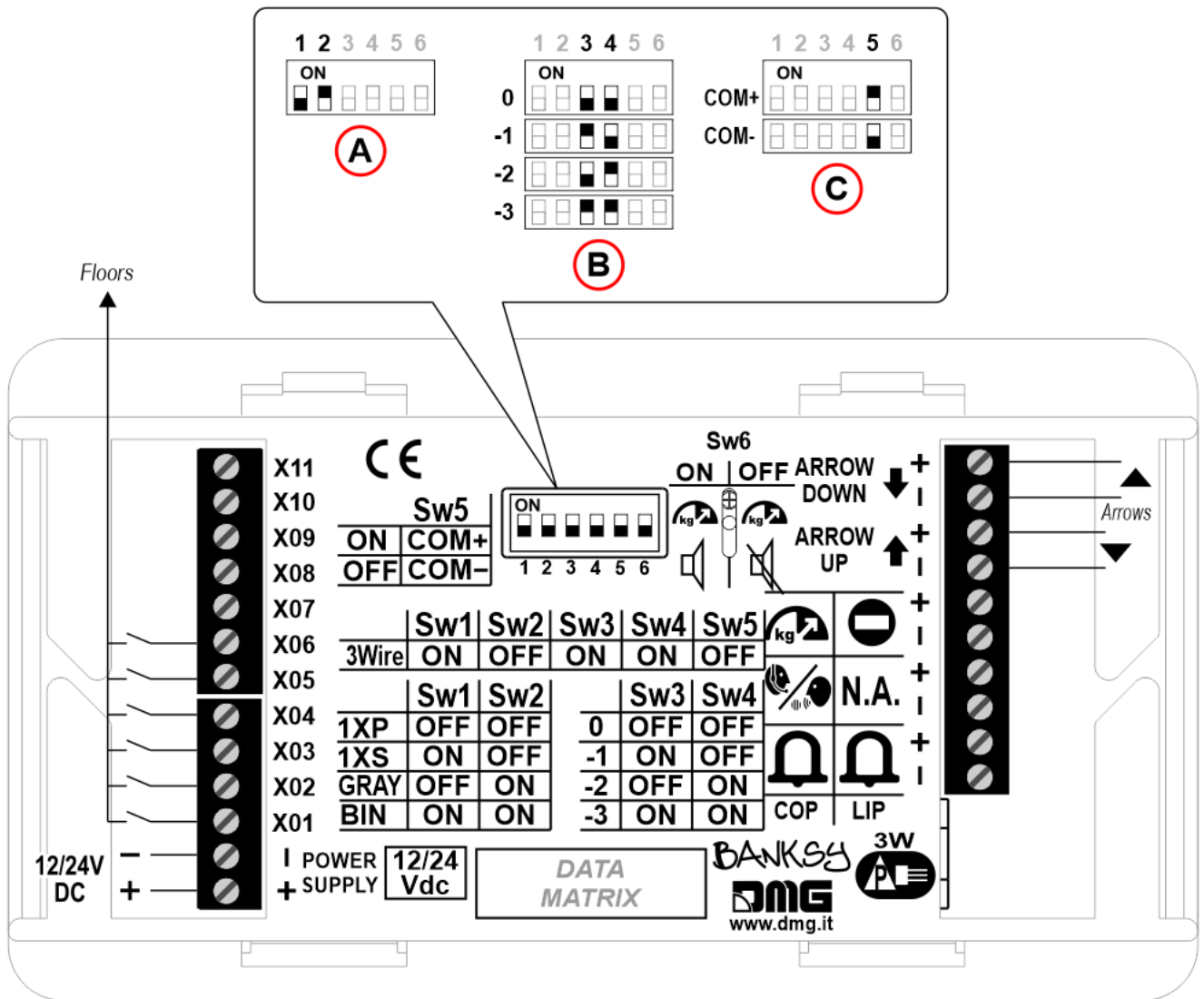

- A) – Coding
- B) – Offset (-3 ÷ 0)
- C) – Common (Inputs)



23 floors max. (-3, 0, 19)

Binary
DB1/DB2

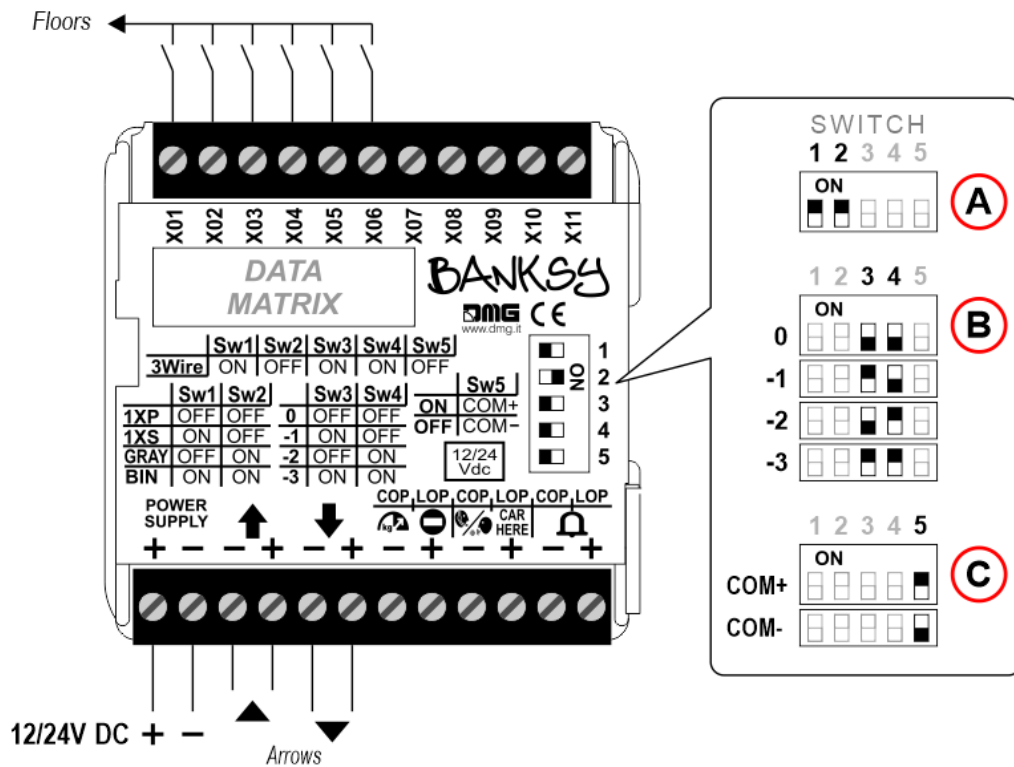

DB3

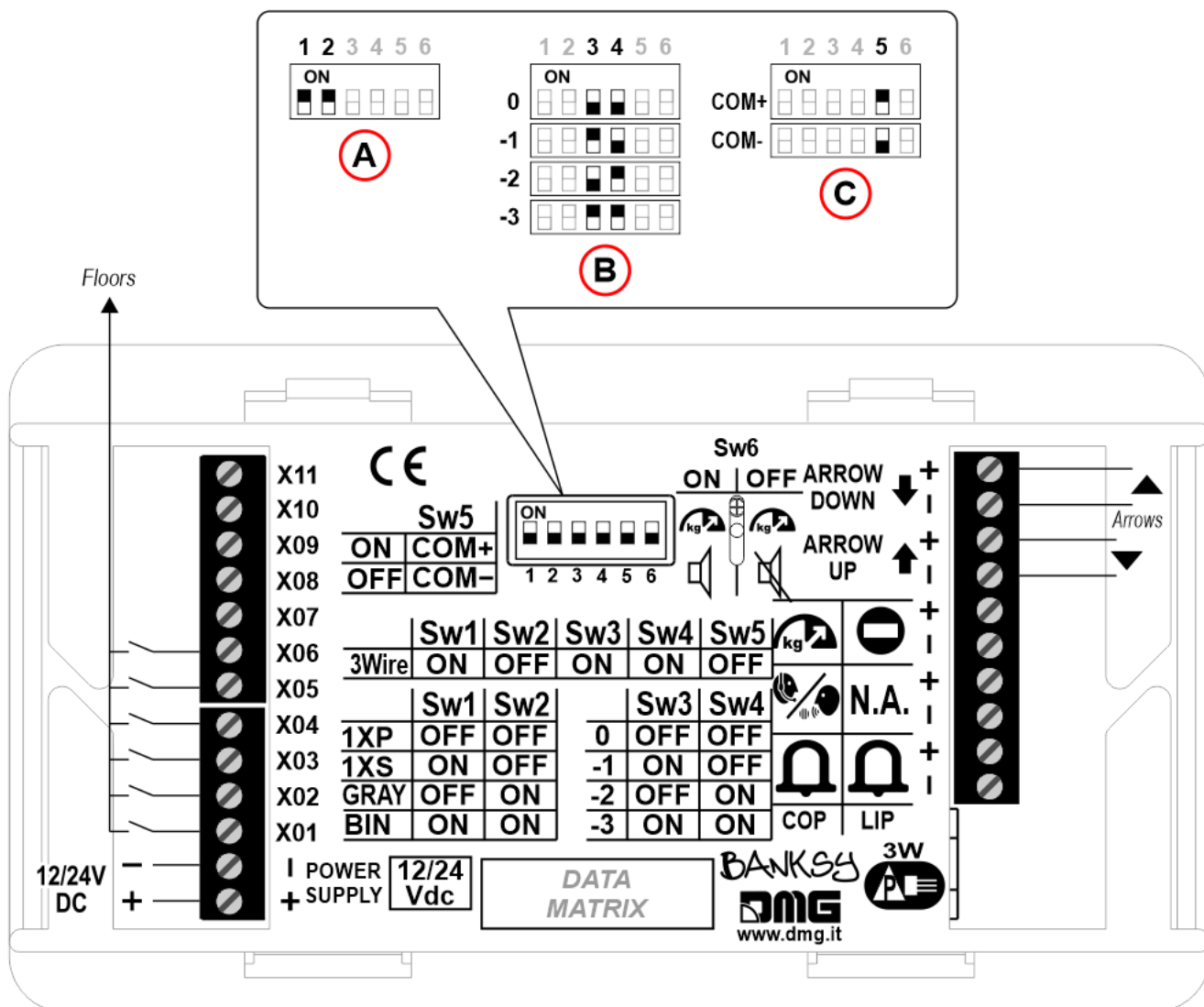

A) – Coding

- B) – Offset (-3 ÷ 0)
- C) – Common (Inputs)



23 floors max. (-3, 0, 19)

Service Messages

Car

DB1/DB2

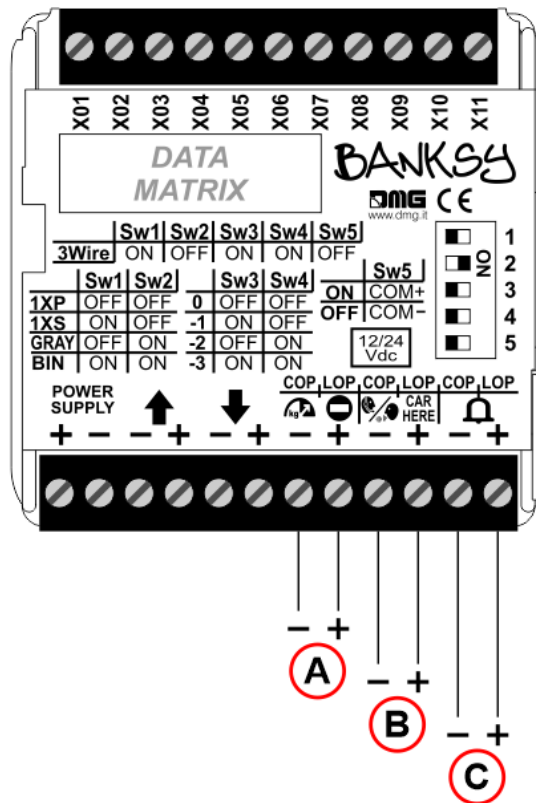

- A) – Overload (S1)
- B) – Communication established (S2)
- C) – Alarm sent (S3)

DB3

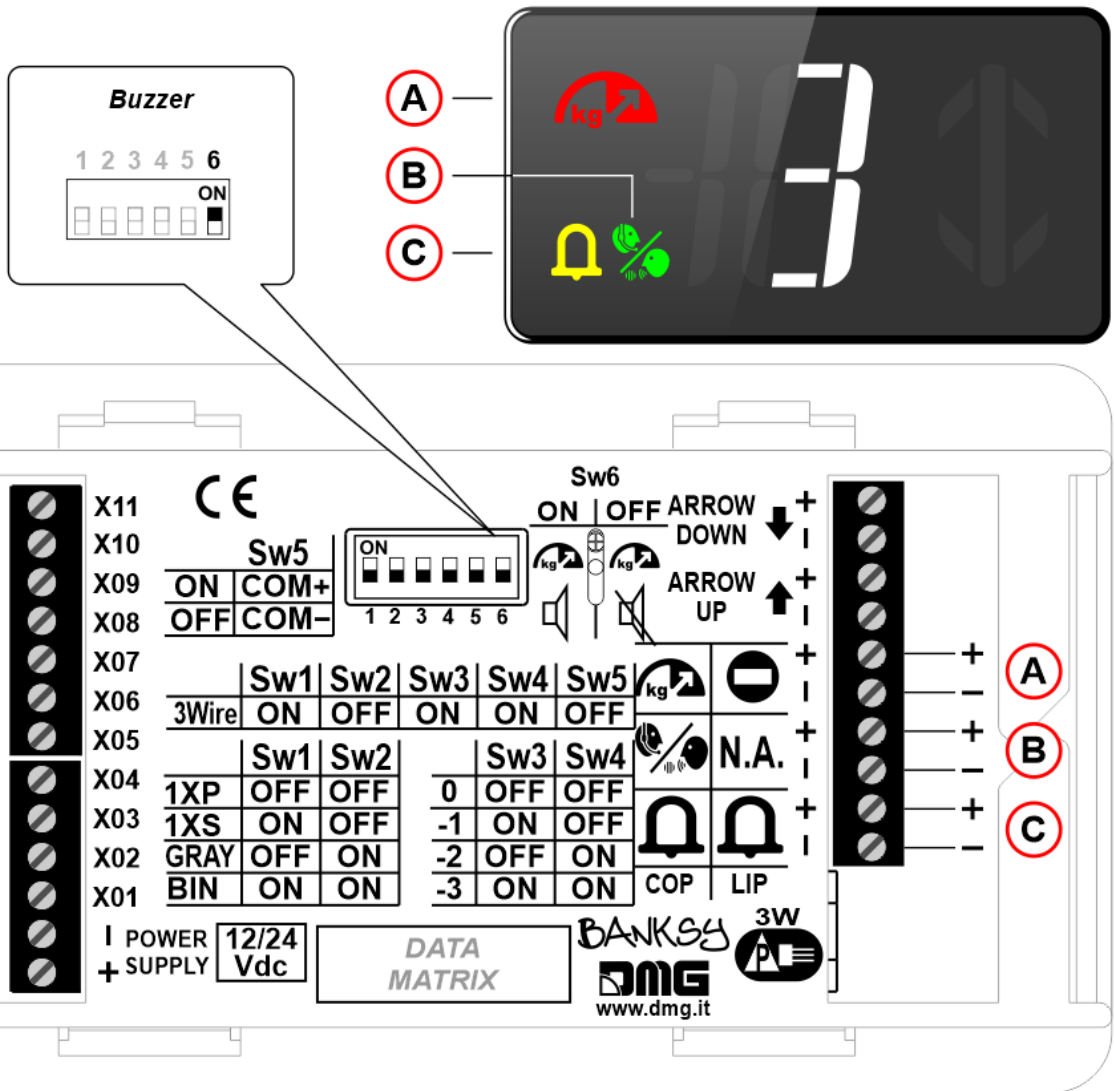

- A) – Overload (S1) + enabling the buzzer if the SW6 switch is in the ON position.
- B) – Communication established (S2)
- C) – Alarm sent (S3)

⊖ Floor

DB1/DB2



A

B

C

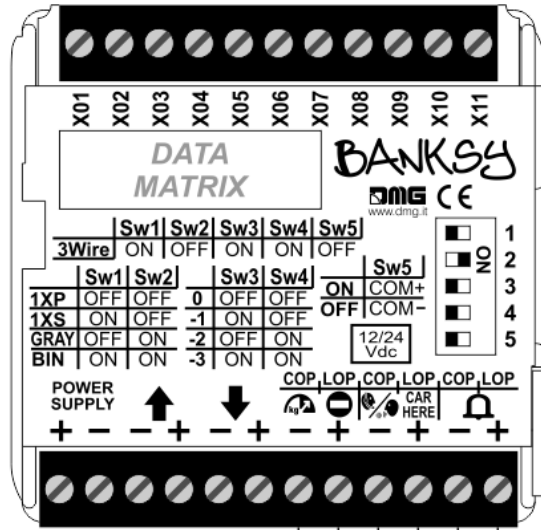

A

B

C

DB3



A

C

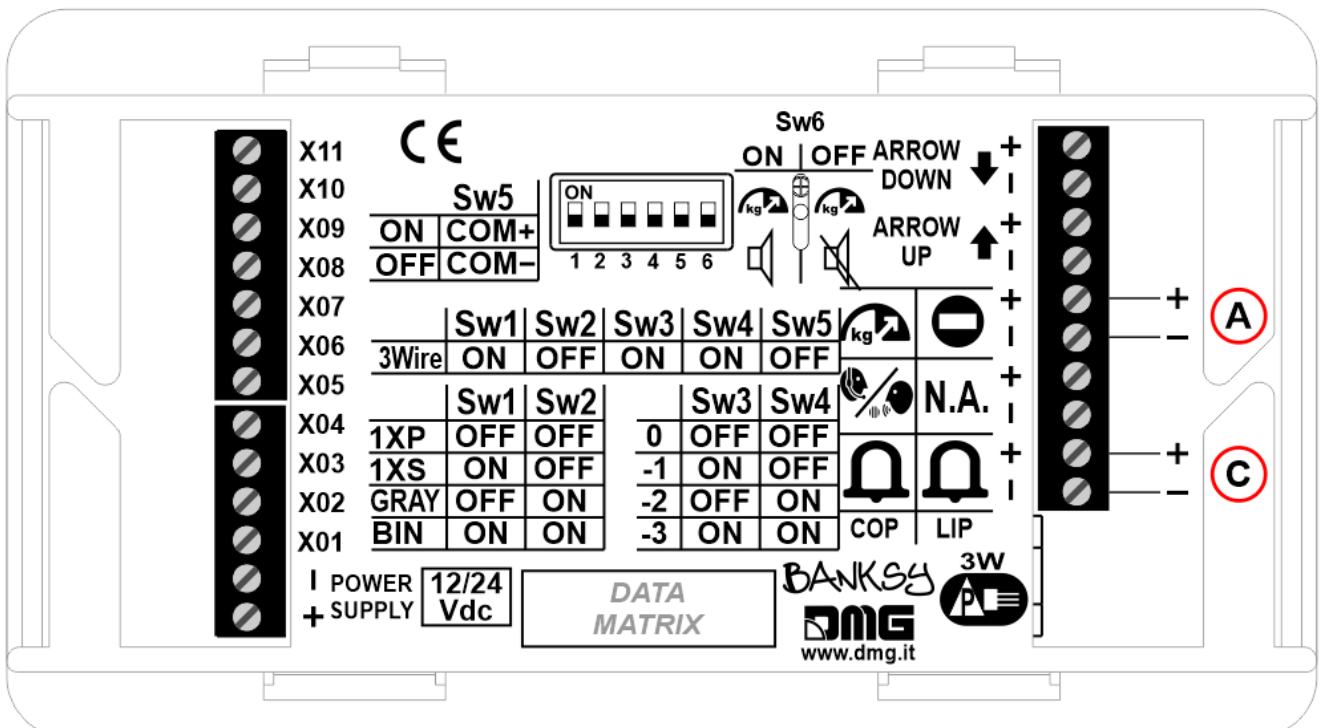

- A) – Out of order (S1)
- B) – Present (S2)
- C) – Alarm (S3)

Datasheet

Dimensions	DB1: 55×55 mm (H15,15mm from the plate surface) DB2: 68,3×70,8 mm (H12,9mm from the plate surface) DB3: 138,3×76,8 mm (H13,5mm from the plate surface)
Power supply	12÷24V DC ±10%
Power supply (position input)	12÷24V DC ±10%
Power supply (arrows)	12÷24V DC ±10% (optoisolated)
Absorption	<p>DB1/DB2</p> <p>7mA per segment (12V) – 10mA per segment (24V) Arrows UP/DW: 14mA (12V) – 20mA (24V) Inputs S1/S3: 10mA (12V) – 21mA (24V) Inputs S2: 10mA (12V) – 48mA (24V)</p> <p>DB3</p> <p>7mA per segment (12V) – 9mA per segment (24V) Arrows UP/DW: 22mA (12V) – 22mA (24V) Inputs S1: 11mA (12V) – 18mA (24V) Inputs S2: 10mA (12V) – 17mA (24V) Inputs S3: 8mA (12V) – 17mA (24V) Buzzer: 14mA (12V) – 15mA (24V)</p>
Operating temperature	-10°C ÷ +50°C
Degree of protection	IP4x

Download

You can download the PDF of this page

DIDO-Banksy-English

Download

Updated on 28 Maggio 2021