



2,8" RAFFAELLO Display

Contents

[Safety and usage cautions](#)

[Mounting](#)

[Wiring Instructions](#)

[POSITION & DIRECTION Input Wiring](#)

[SERVICE MESSAGE Wiring](#)

[Settings](#)

[Datasheet](#)

[Raffaello 4.3"](#)

[Video Tutorial](#)

[Firmware](#)



✔ Updated to EN81-28:2018 regulation.

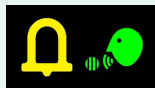

Safety and usage cautions

Before installing our products, we recommend you to consult the section about safety and usage cautions at the link below.



Mounting

➤ Raffaello 2.8"

With welded pins on 1,5÷2 mm pushbutton panel

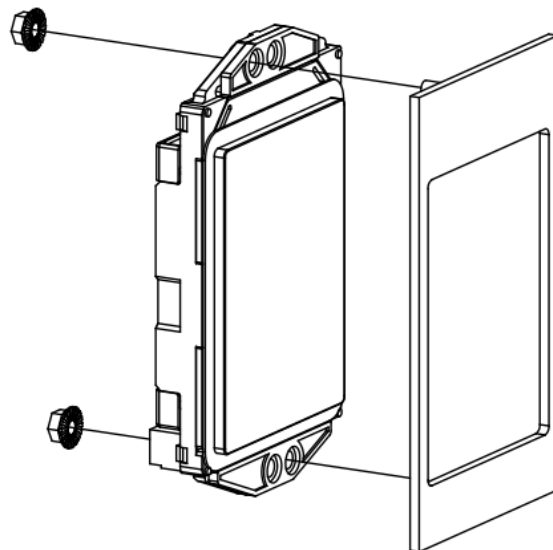
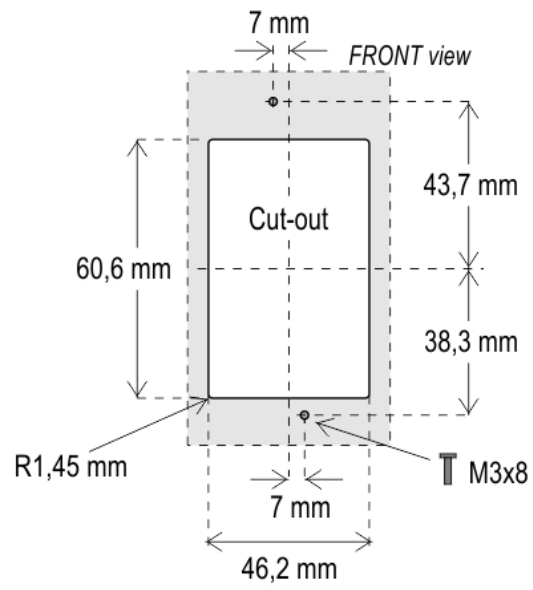

With pins on backplate (for 1 mm pushbutton panel)

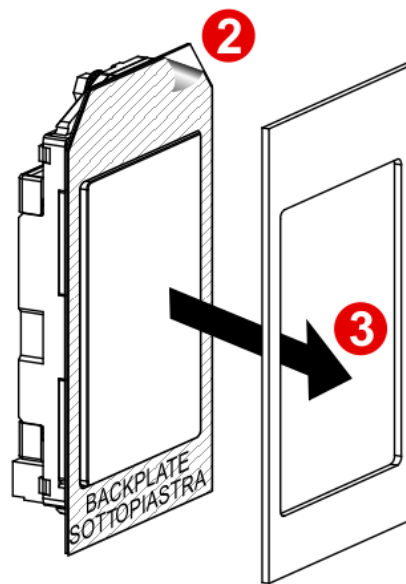
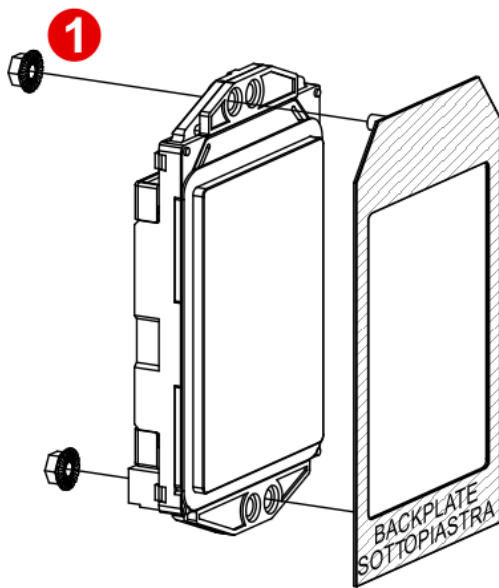
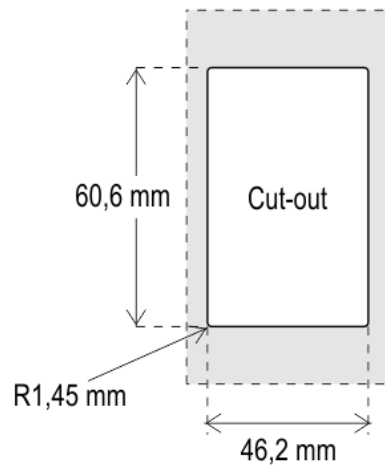

⊖ Raffaello 2.8"
(EN81-71)

With welded pins on 2÷3 mm pushbutton panel

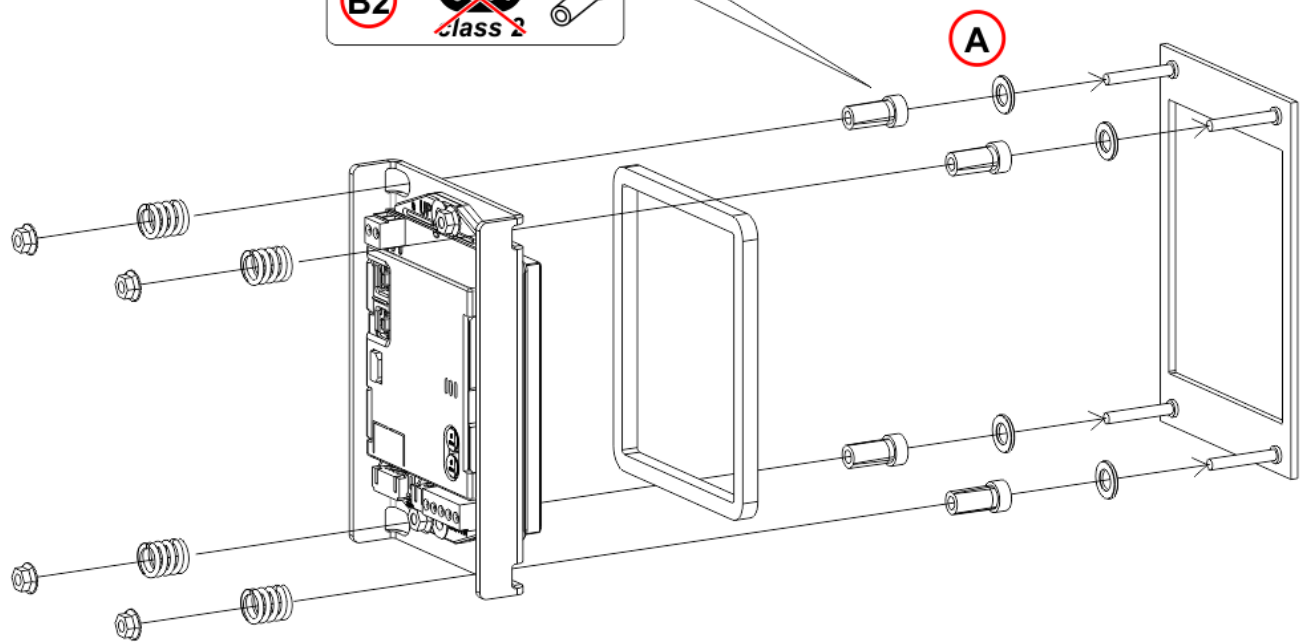
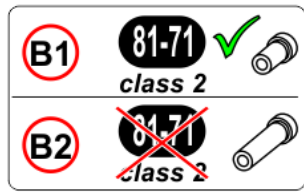
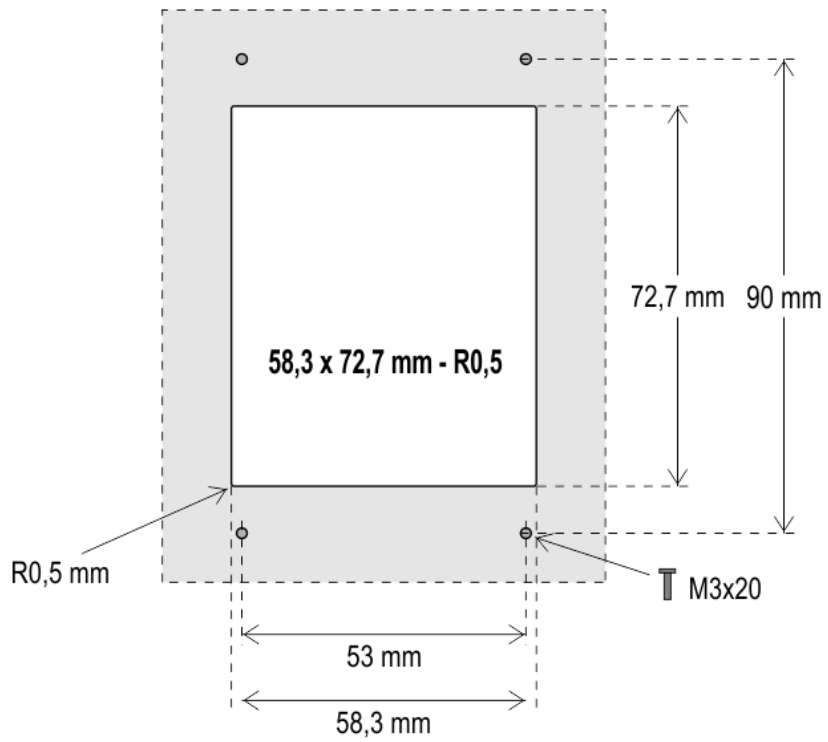

Wiring Instructions

POSITION & DIRECTION Input Wiring

DMG CAN serial protocol

CAR

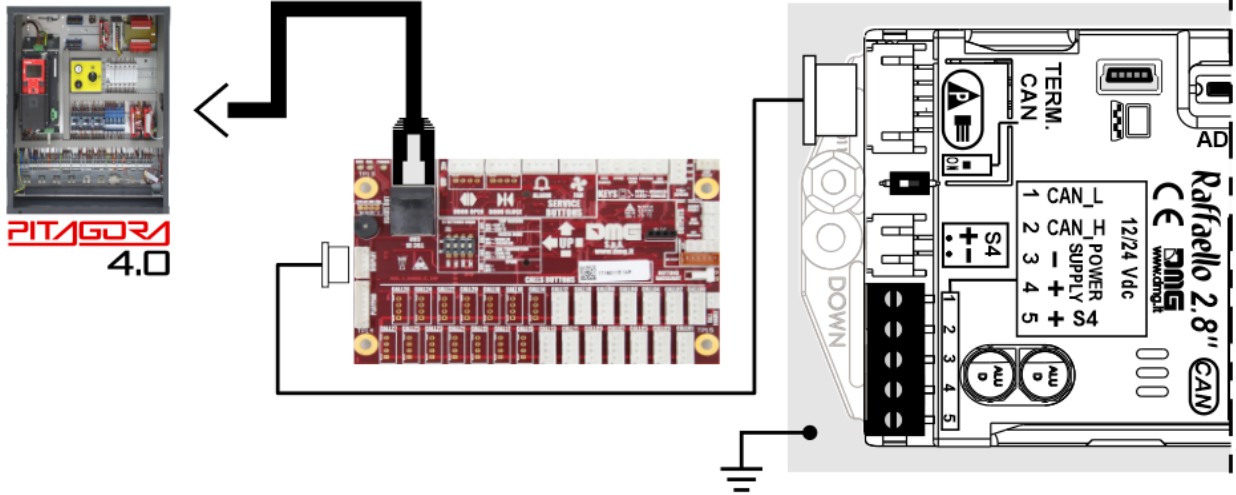

FLOOR

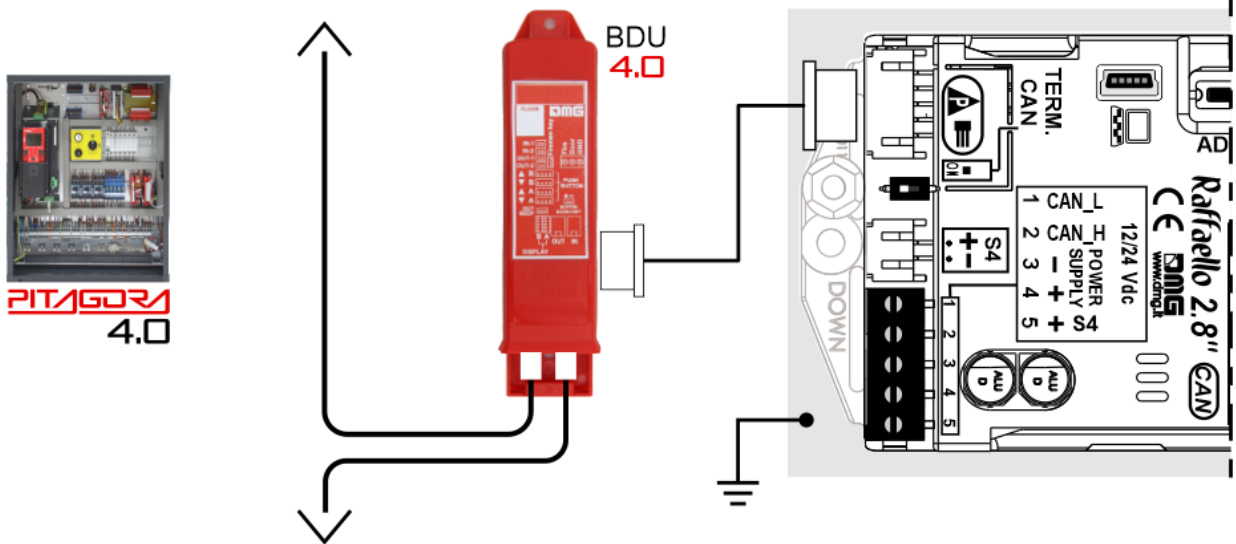

DMG

3-wires serial

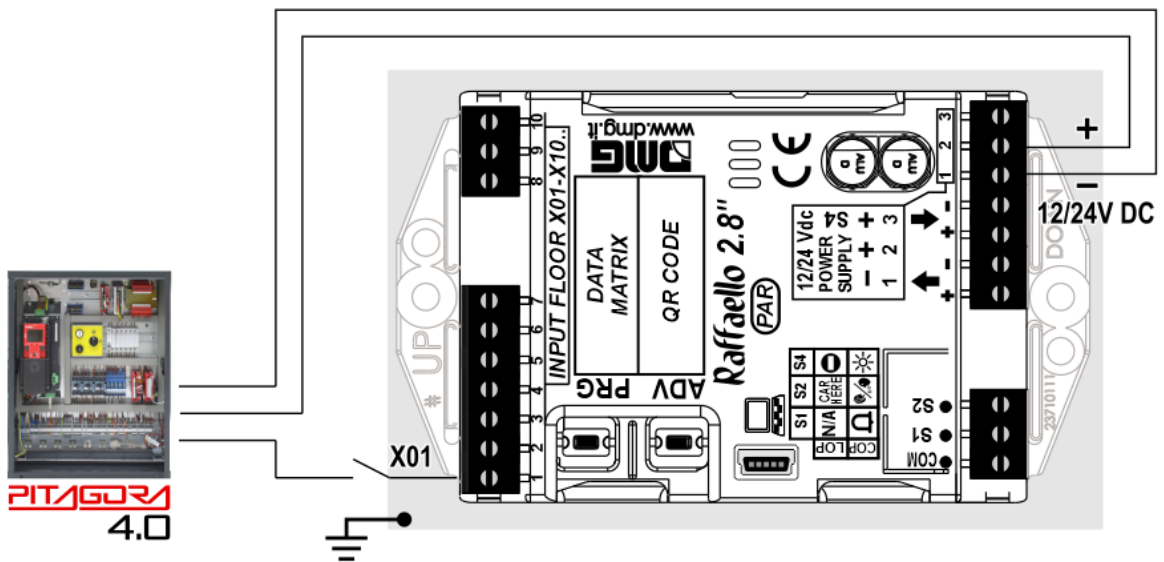

Encoder DEUM



For more details please refer to the [Encoder DEUM](#) support page

DMG

CAN serial protocol

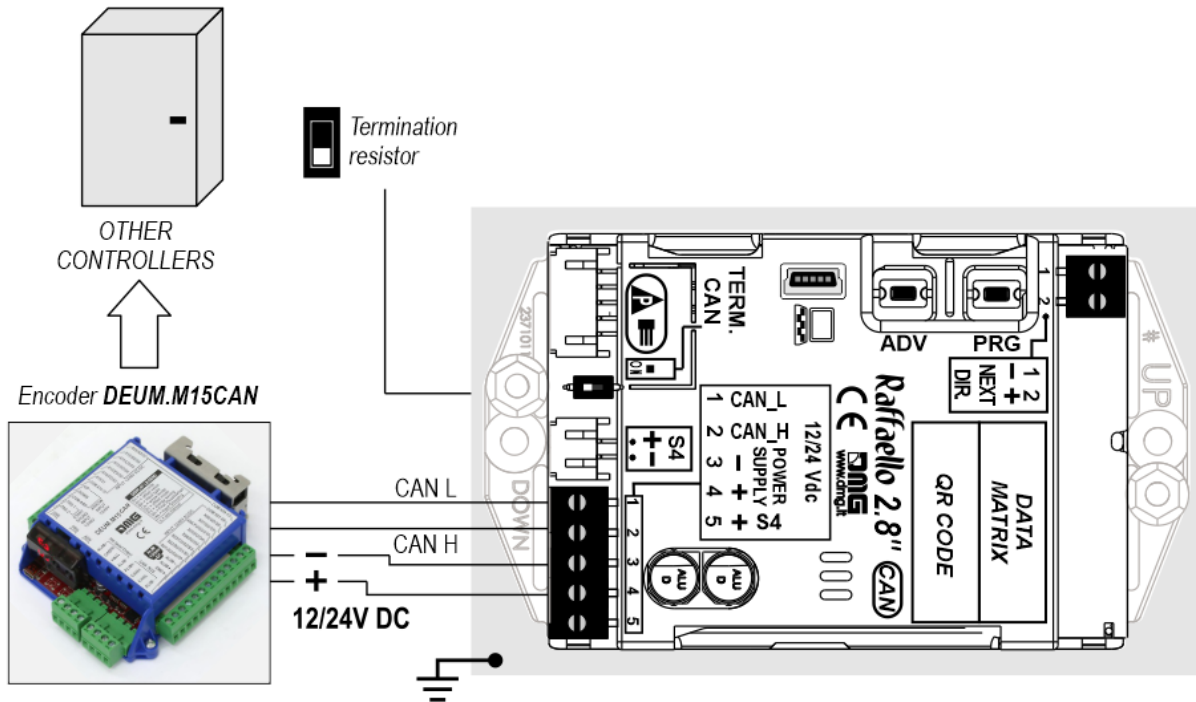

TERM.CAN



Activate the CAN line termination both on the elevator car position indicator and the last position indicator of floor.

DMG

3-wires serial

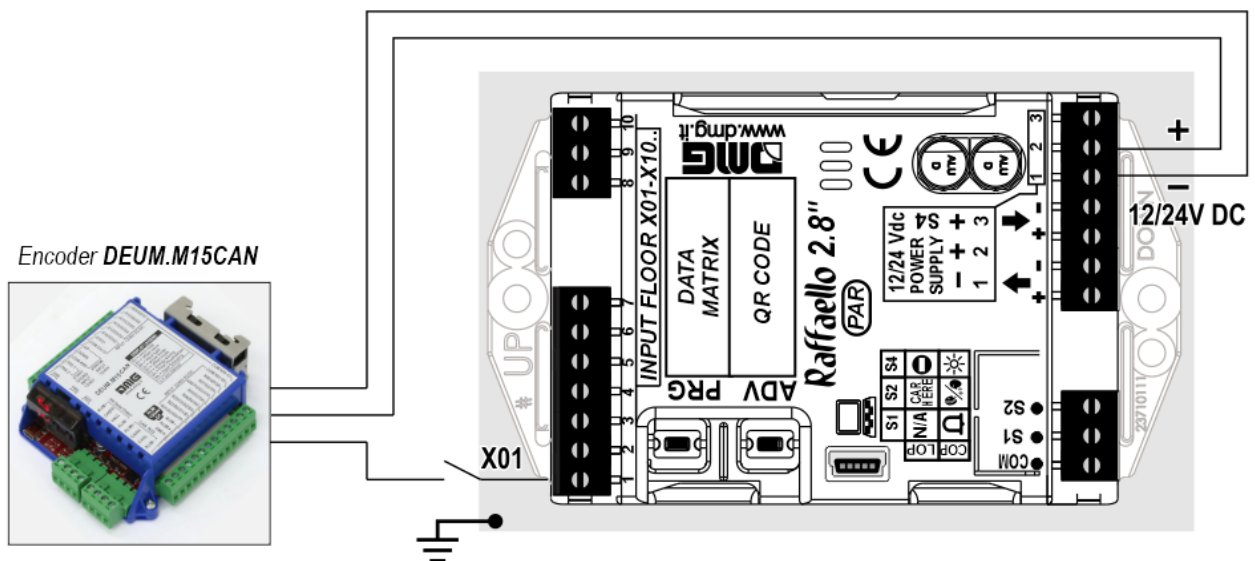

Other Controllers

Proprietary CAN protocol

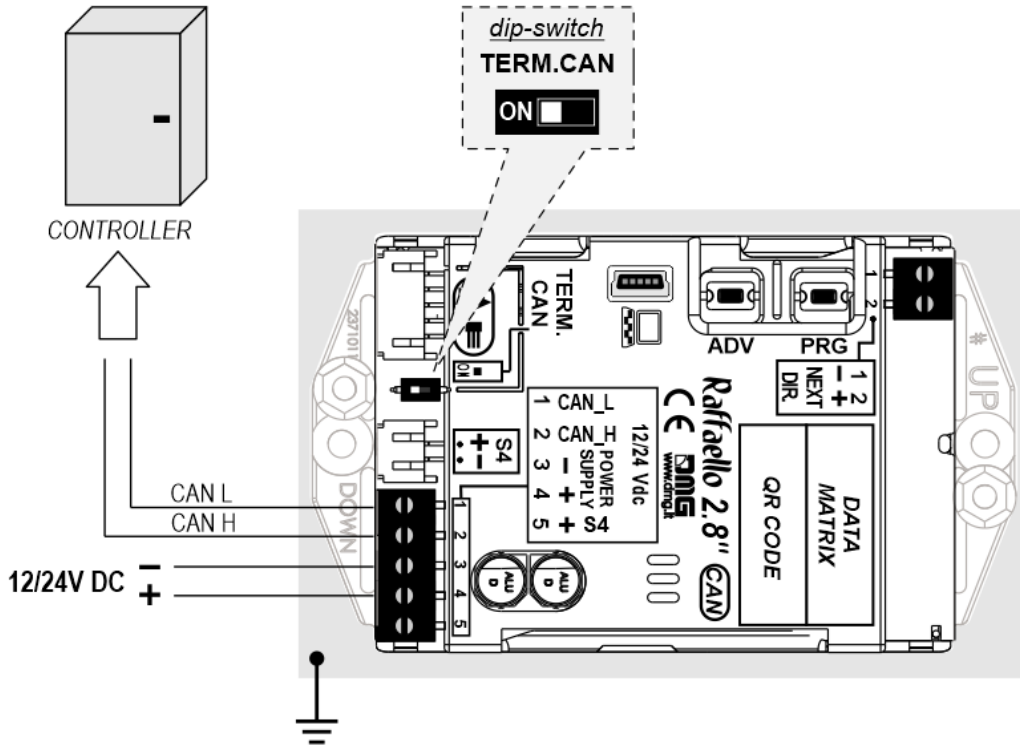

TERM.CAN



Activate the CAN line termination both on the elevator car position indicator and the last position indicator of floor.

1 Wire / Floor

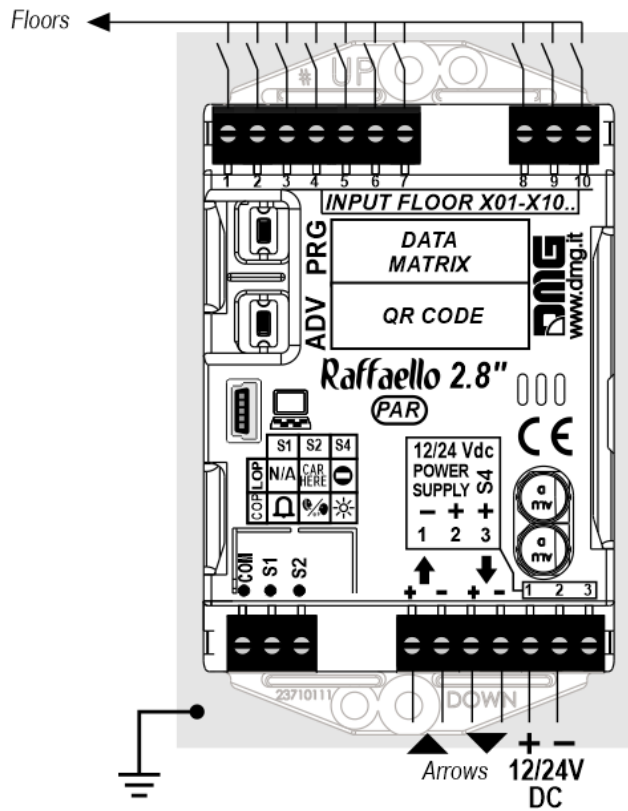

10 floors max.

1 Wire / Segment

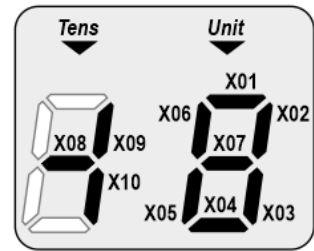
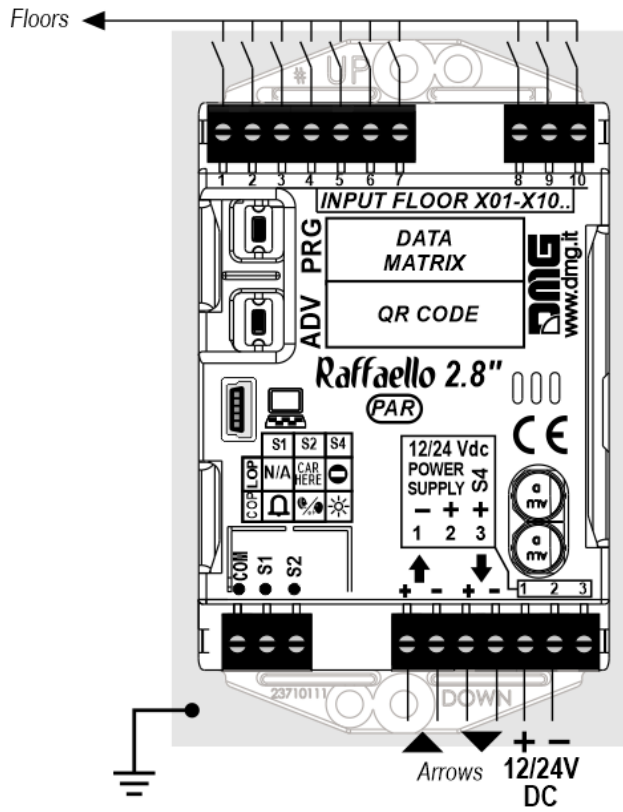

29 floors max. (-9, 0, 19)

Gray / Binary

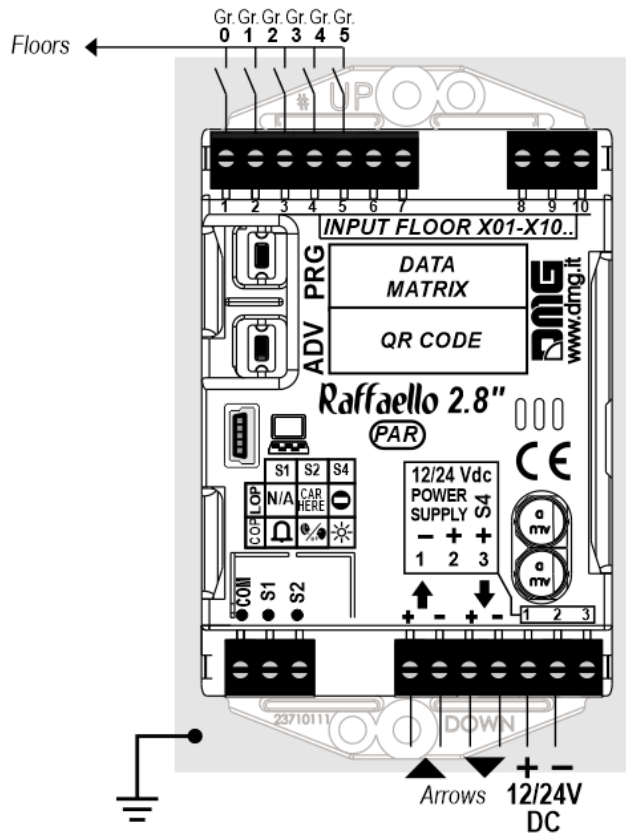

72 floors max. (-9, 0, 62)

TKE/MEA/Autinor

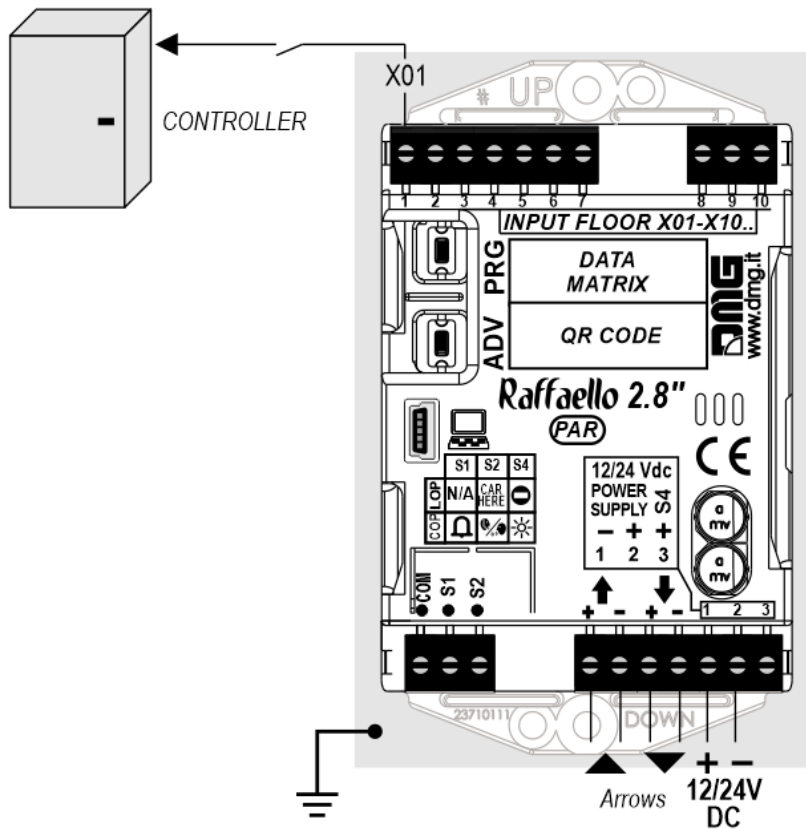

SERVICE MESSAGE Wiring

Parallel display

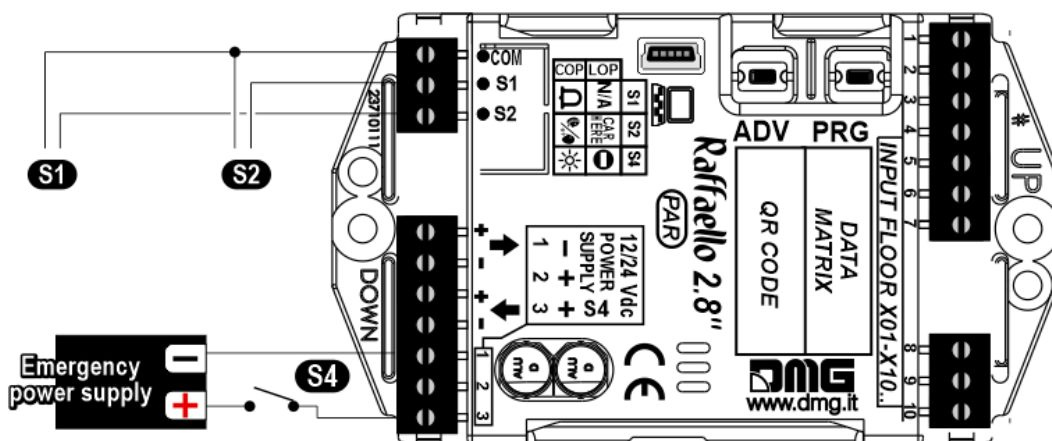



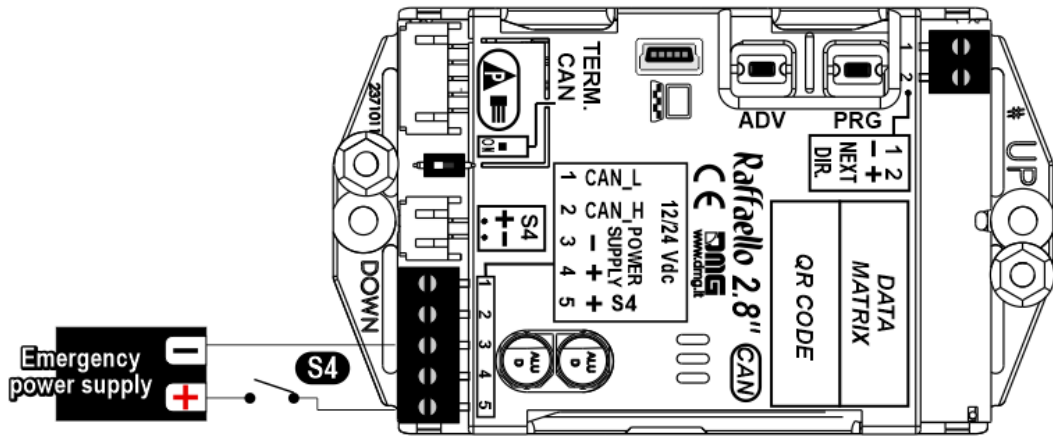



CAN serial display (*)







(*) – Service messages can also be piloted, through serial bus, in two different ways:

- by controller DMG
- by encoder **DEUM.M15**

	Car	Floor
S1	 Alarm sent	 Allarme (legge 13)
S2	 Communication established	 Car here
S4	 Antipanic light	 Out of service

Settings

 ADV Setup Key	 ADV Exit / Back	 PRG Access Menu Key	 PRG Value setting (>3 sec.)
--	--	--	--

Navigation menu keys

General



The display navigation menu is in English only; to see the correct menu items we recommend setting the DIDO website language to English.

MENU	MENU ITEM	AVAILABLE CHOICES	INPUTS
			Parallel CANBUS

MENU	MENU ITEM		AVAILABLE CHOICES	INPUTS			
Input			Serial / 1 wire per floor / segment Gray / Binary / Pos.Sensor TKE / MEA / Autinor / CAN DMG	•	•		
Options	Interface Options	Display Configuration	COP / LOP / LIP	•	•		
		Arrow Configuration	Direction / Next Dir.		•		
		Car at Floor	No / Yes		•		
		CAN Baudrate	250k, 125k, 10k, Auto		•		
		Convert Mezzanine	No / Yes		•		
		Offset Value	-9 / ... / 0 / ... / +9	•			
		First Visualization	Blank / Zero	•			
		Common Selection	Negative / Positive	•			
		Arrow Type	Fixed arrows / Scrolling arrows	•			
		Enable AUX Signals	10 + 0 / 6 + 4	•			
		Input Filtering	0 ... 20	•			
		Screensaver timer	Disabled / 10-20 / 30-60 / 60-120	•	•		
	Graphic Options	Font		Dado / Classic Bold / Lagoon / Dot Matrix	•	•	
		Flat Style	Symbol color	White / Red / Orange / Blue / Gray / Black	•	•	
			Background color	Black / Pacific Blue / Navy Blue / Reef Blue / Light Gray / White / Orange / Red	•	•	
			Specials	White-Green / White-Lilac / Purple-Yellow / White-Gray	•	•	
		Gradient Style	Style	Black & White / Red Passion / Gray Goose / Blue Shades	•	•	
			Color	Galaxy / Ocean Dream 2/1 / Reef Blue / Purple haze / ...	•	•	
		Floor Symbols		Show / Hide	•	•	
		Arrows		Show / Hide	•	•	
		Fixed Symbols Positions		No / Yes	•	•	
		Filter Blinking Signals		No / Yes	•	•	
		Message Mode		Alternating / Fixed	•	•	
		Orientation		Landscape (Horiz.) / Portrait (Vert.) / Rev.Landscape / Rev.Portrait	•	•	
		Signal Inputs Configurations	Input S1 / S2 / S4		•	•	
		AUX Signals Configurations		AUX Signal 1 / 2 / 3 / 4	•	•	
		Reset All Settings				•	•
		?	DEMO mode		No / Yes	•	•

MENU	MENU ITEM	AVAILABLE CHOICES	INPUTS
	Firmware Version / Life Time (internal use)		• •
Floor Numbers	Numbers / Letters	Choose the Numbers / Letters	•

➤ Set up Raffaello as elevator car indicator or floor indicator

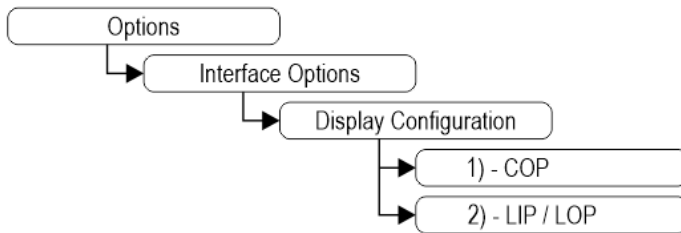

1) – Elevator car Position Indicator (default)

2) – Hall Position Indicator

➤ Arrow setting up

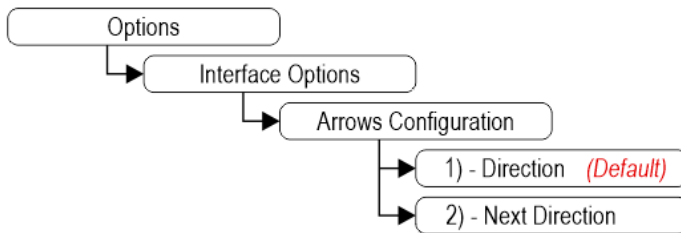

1) – Direction arrows (default)

2) – Next direction arrows (instructions below)

Next Direction Arrows enabled from input

Arrows light up only on the position indicators with the “NEXT DIRECTION” input powered.

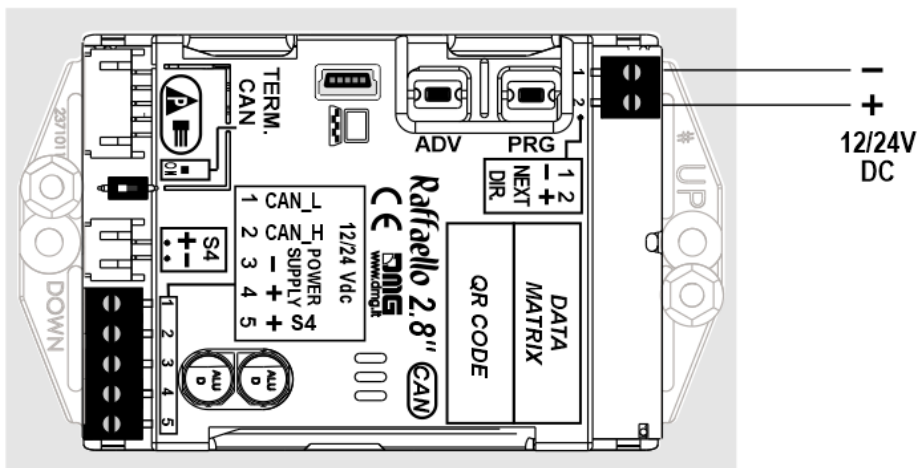

If the **DEUM Encoder** is used, please refer to the relevant manual

Next Direction Arrows locally programmed

Through the addressing procedure one can permanently assign to each indicator the information of the floor on which it is mounted; in this way, next direction arrows only light up at the floor where the elevator car is positioned.

– Addressing procedure

- 1) – Connect all position indicators to the ENCODER or PLAYBOARD controller.
- 2) – Position elevator car on the floor of the Display which needs to be directed.
- 3) – Verify that the characters/numbers/letters visualized are the desired ones.
- 4) – Press and hold the ADV key and wait for the display to flash for 3 seconds to confirm.
- 5) – Repeat procedure for each floor.

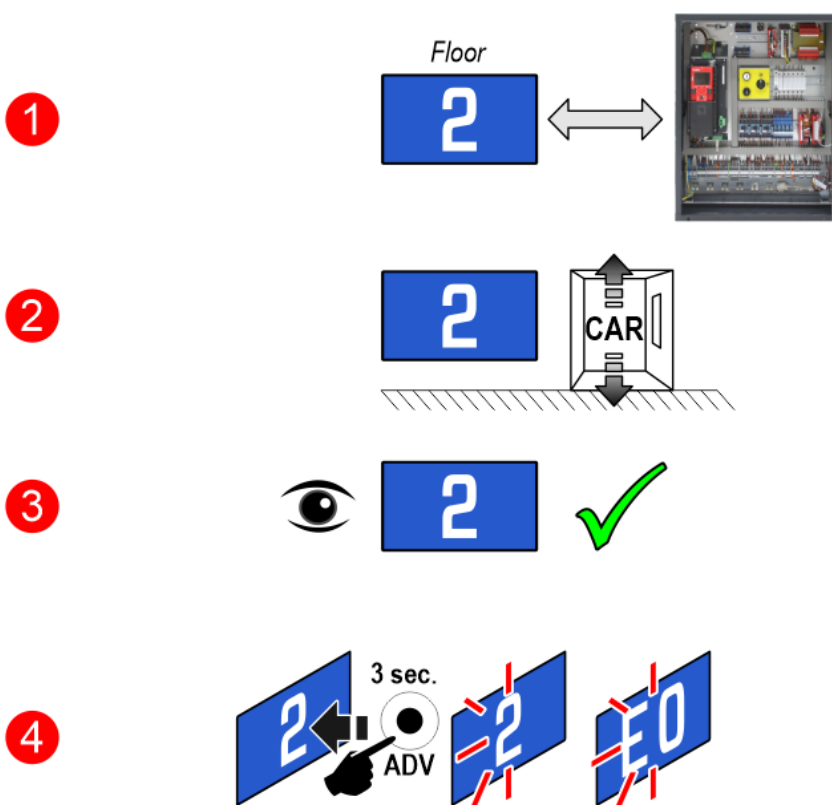

If the **DEUM Encoder** is used, please refer to the relevant manual

– Set up CAN BUS protocol transmission speed

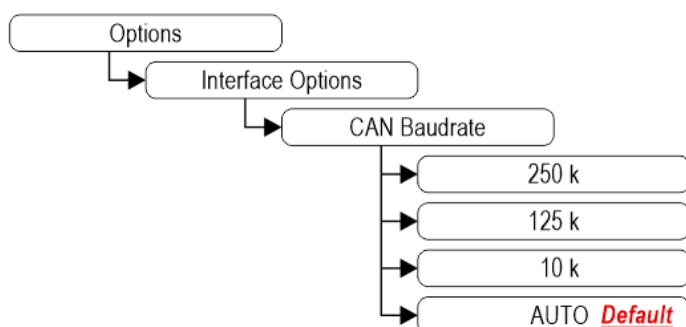

Intermediate floors visualization

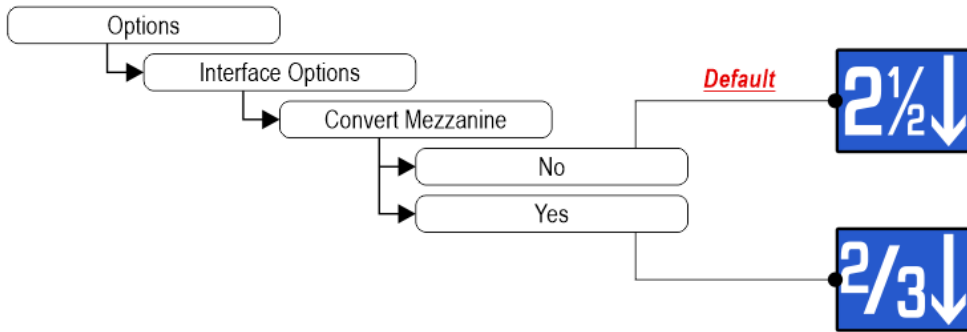

Set up floors OFFSET

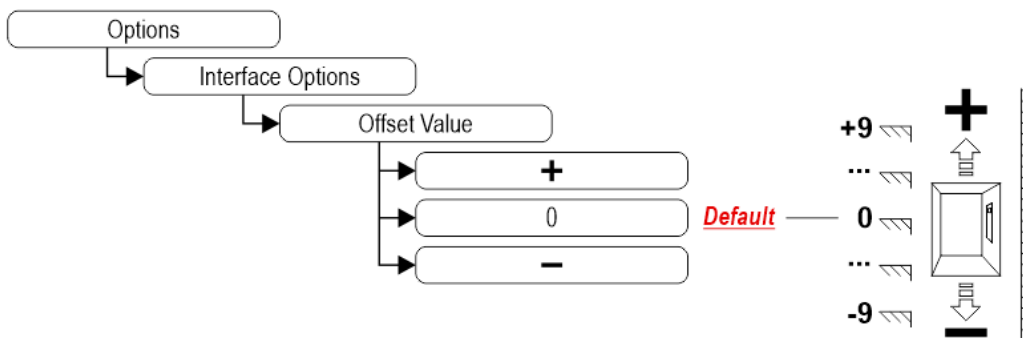

Set up first visualization

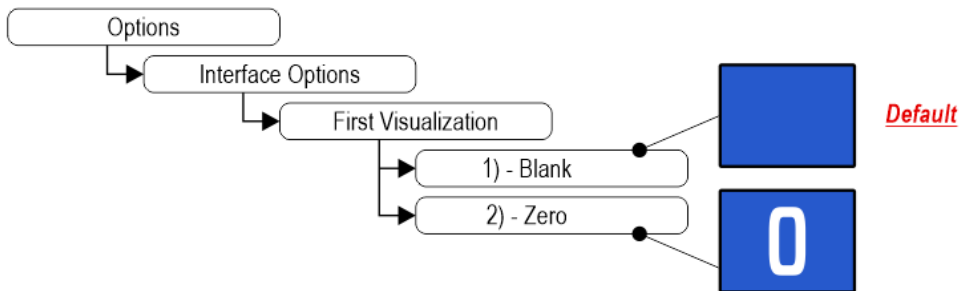

- 1) - It does not display any numbers
- 2) - Lowest floor

Set up Parallel position common input

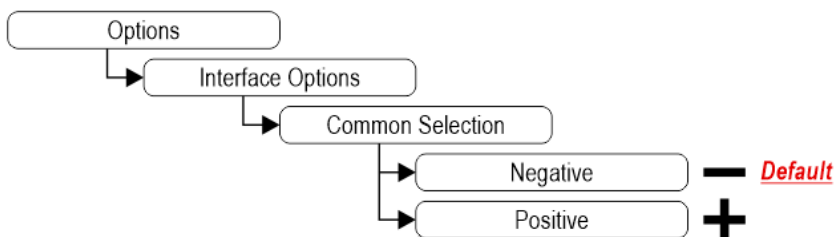

Set up scrolling arrows

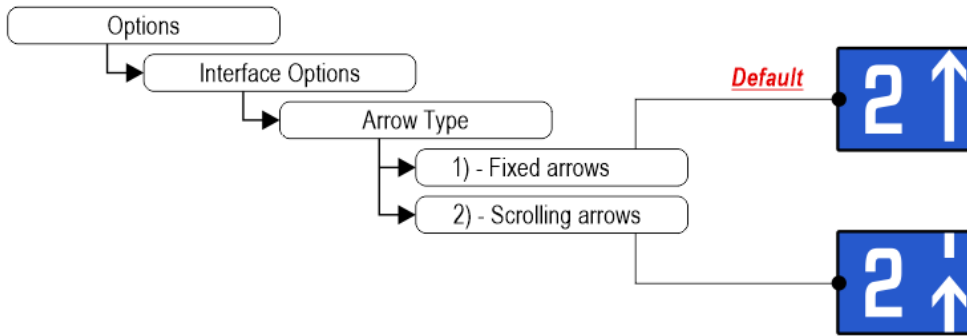

- 1) – Fixed arrows
- 2) – Scrolling arrows

Enable auxiliary signals

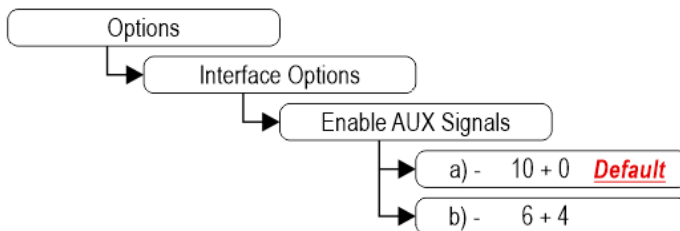

- a) – 10 Floor parallel inputs (X01÷X10) + 0 AUX Signals
- b) – 6 Floor parallel inputs (X01÷X06) + 4 AUX Signals (X07÷X10)

Set up the display delay of floor change

The display delay helps avoiding visualization errors during floor change.

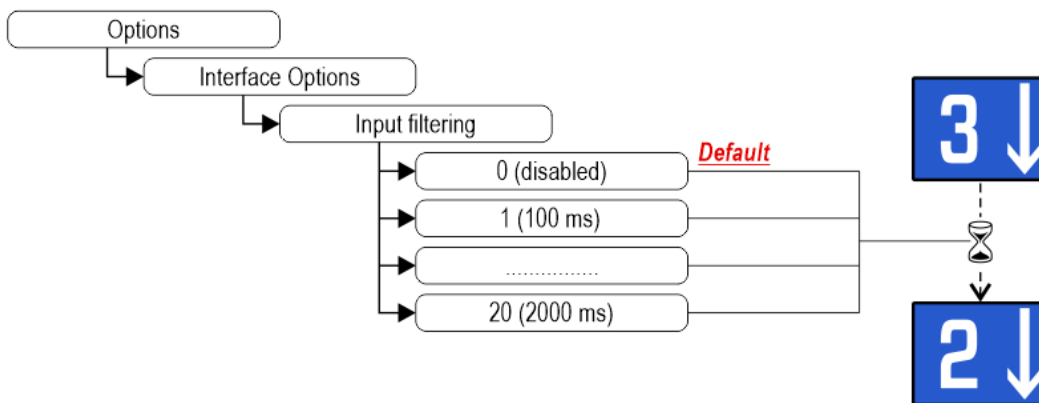

Enable energy saving function

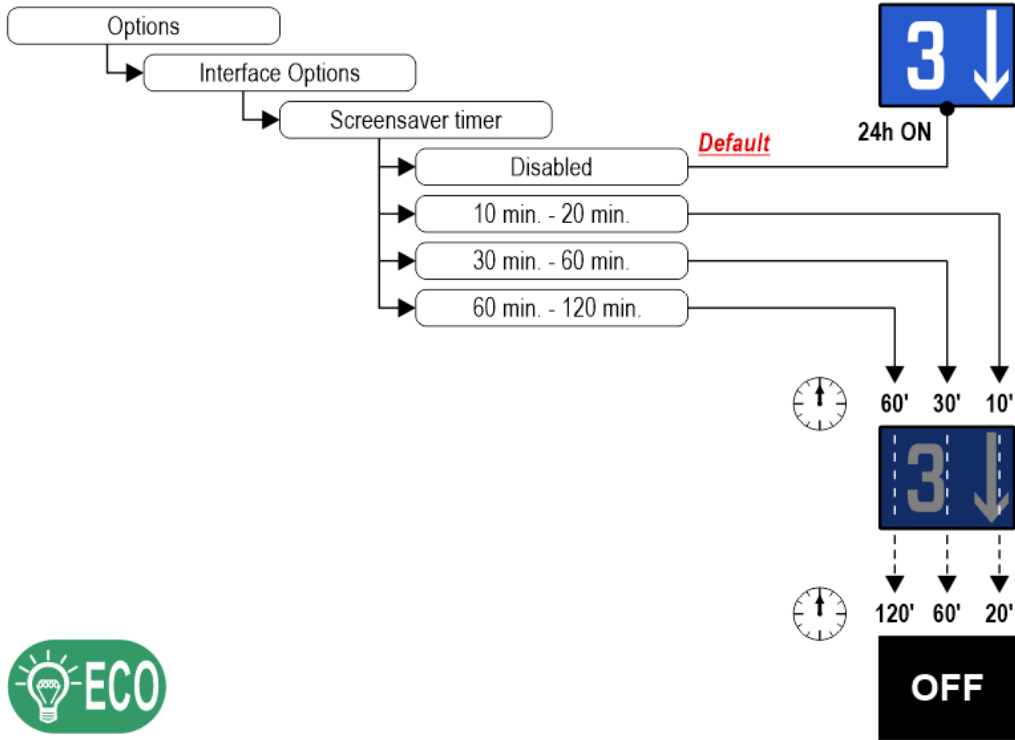

"Energy saving" mode to reduce consumption when idle.

Set up Font

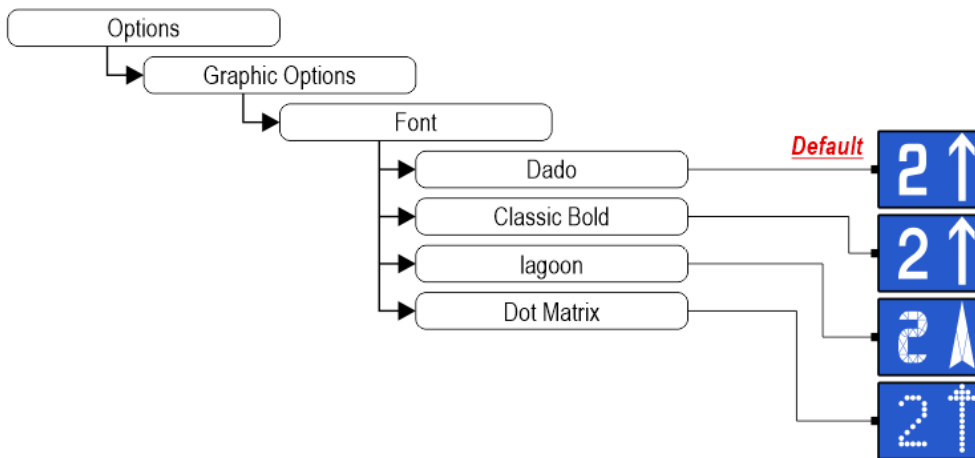

Set up flat Style Color

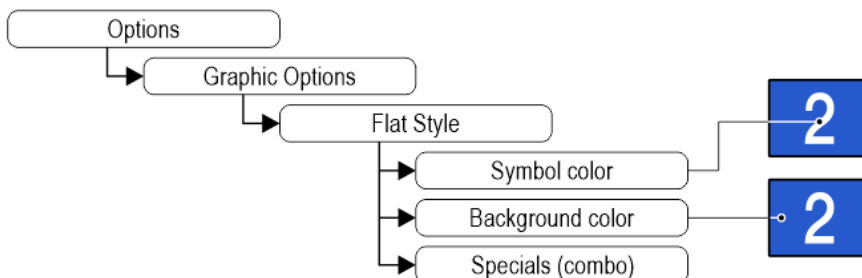

Set up gradient Style Color

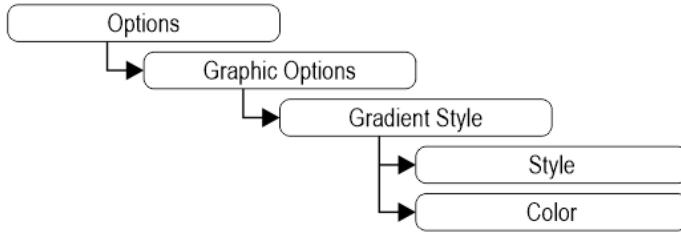

Show/Hide position

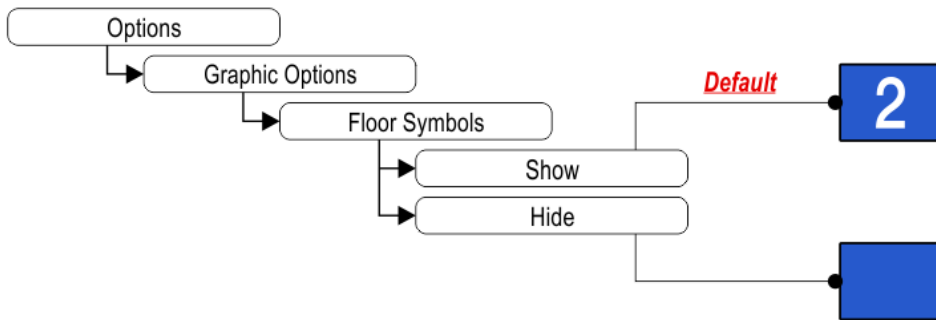

Show/Hide arrows

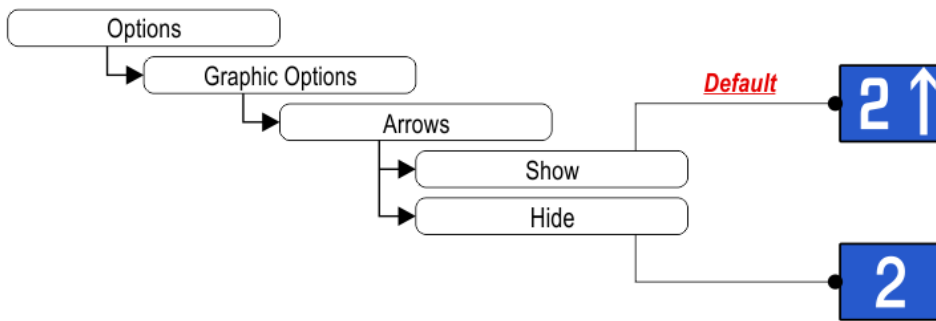

Set up Symbols position

Landscape orientation modes only.

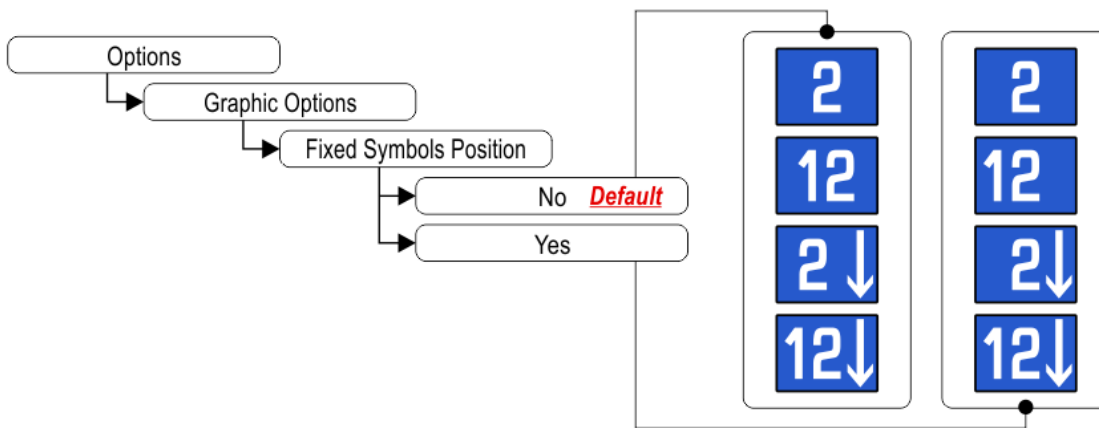

If "Yes", the symbols will stay in fixed positions independently of the arrow status.

Signalizations (visualization)

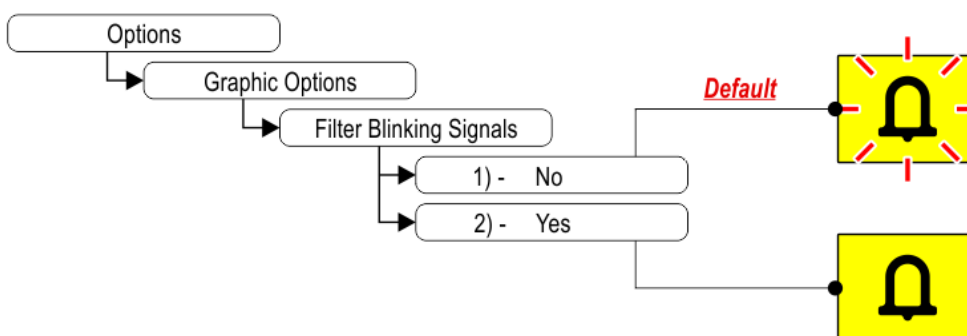

- 1) – Fixed or blinking signalizations (input from controller).
- 2) – Fixed signalizations.

Set up Viewing mode signalization

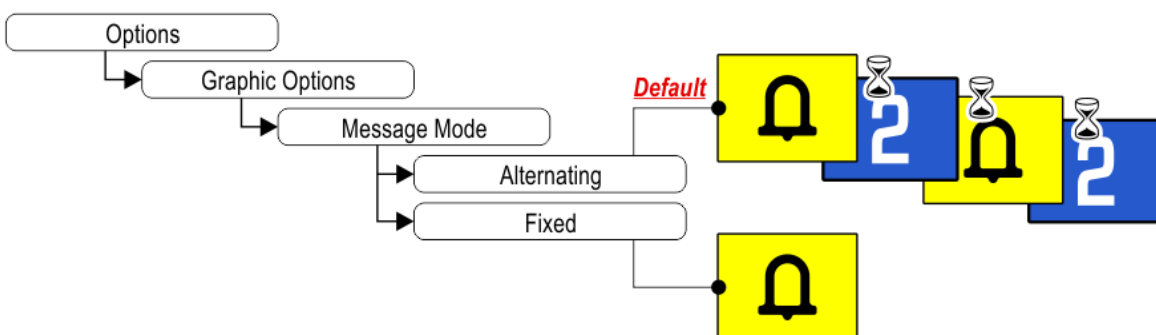

Set up Display orientation

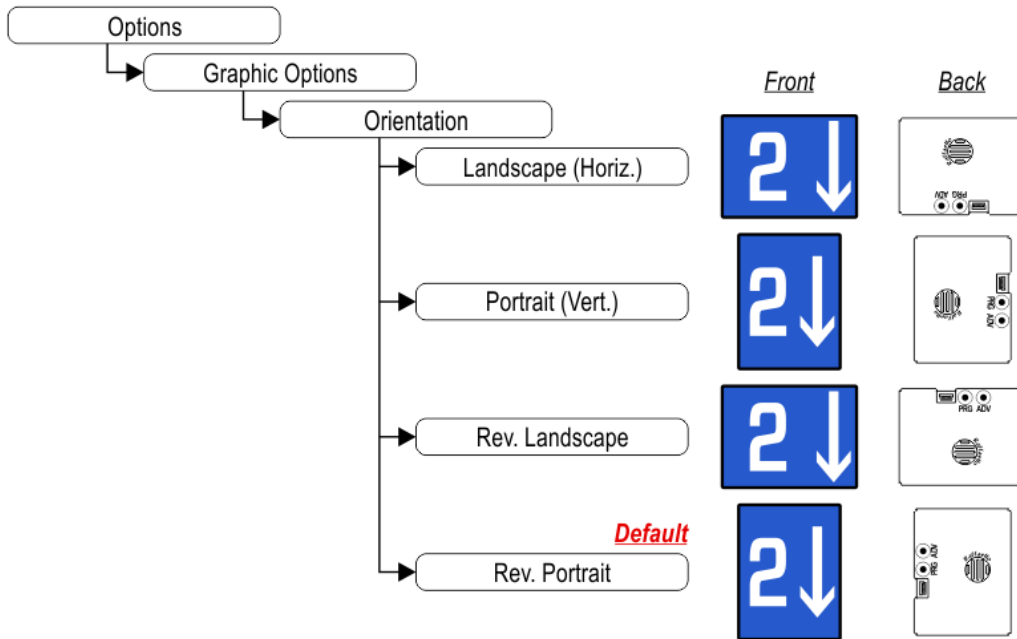

Portrait version: For vertical LIP use only.

Set up service message inputs

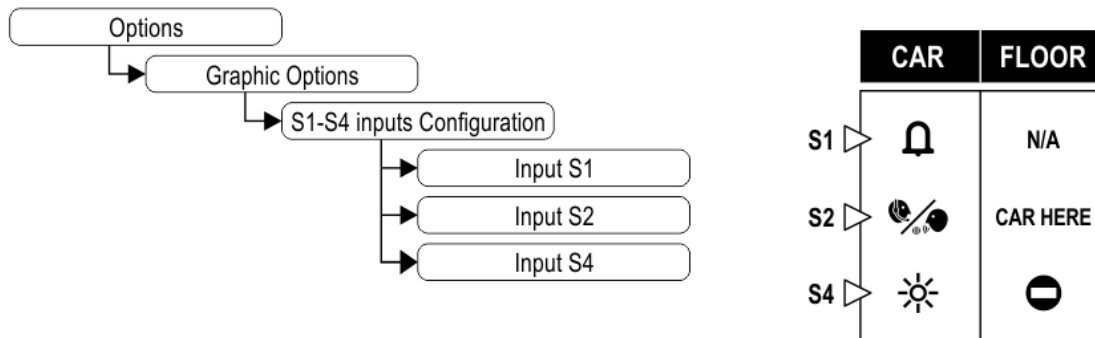

Set up auxiliary signal

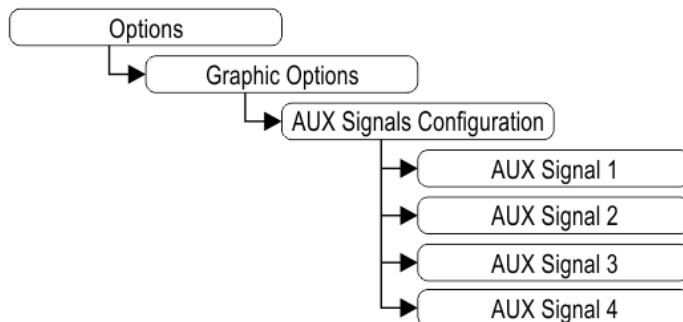

Restore the factory settings

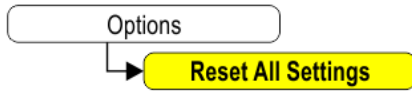

The display original factory settings will be restored and configurations will be deleted.

⊖ Floor customizations

1) Car at floor

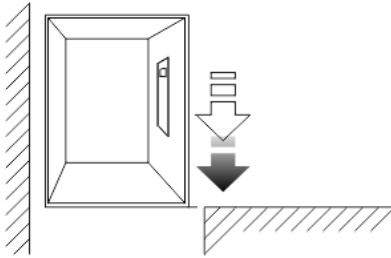

2) Set up Floor Numbers / Letters

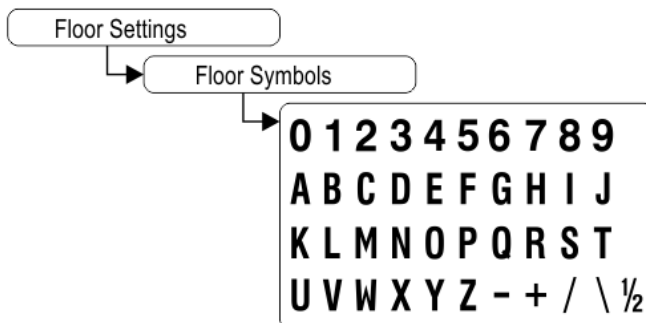

Datasheet

Raffaello 4,3"

Dimensions	90x60xh20 mm 100x67xh26 mm (EN 81-71)
Screen (Viewable area)	57,6×43,2 mm / 320×240 pixel
Power supply (position input)	12÷24V DC ±10%
Absorption	<i>DISPLAY</i> 12V DC: Max 63mA • 24V DC: Max 46mA <i>PANIC LIGHT</i> 12V DC: Max 60mA • 24V DC: Max 31mA

Indicators inputs	S1 / S2 / S4: 12÷24V DC ±10% (opto-isolated) Impedance = 3Kohm
Operating temperature	-10°C ÷ +50°C

Video Tutorial

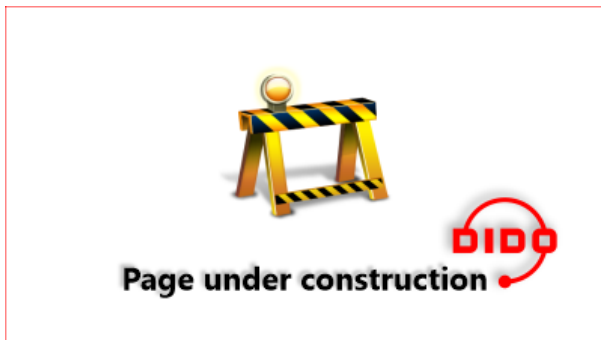

Firmware

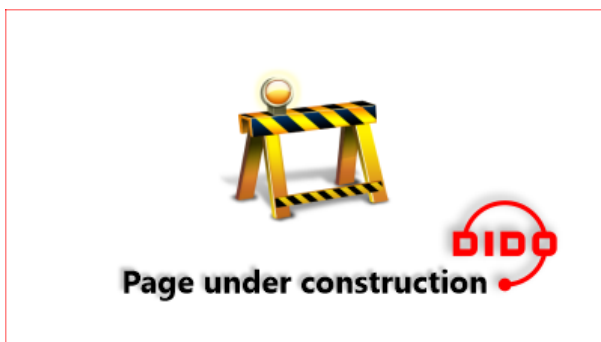

Updated on 24 Maggio 2021