



JUNIOR 4.0

User Manual
English
v 1.11



SAFETY WARNINGS

INSTALLATION

The control panel must be installed indoors with a pollution degree of no more than 2.

The enclosure of the control panel has an IP2X degree of protection.

The installation and maintenance of the control panel must be done by qualified and experienced personnel after careful reading of the manuals and electrical diagrams supplied with the control panel.

Electrical protection must be carried out by means of Automatic circuit breaker and earth-leakage protection coordinated with the earthing system which are the responsibility of the customer unless otherwise specifically requested.

Refer to the electrical diagram supplied with the control panel for the following protection circuits:

- magnetothermic protection of the motor circuit
- magnetothermic protection of the safety circuit
- protection by fuses of all the other circuits

Measures for protection against electric shock:

- The control panel casing is metallic and must be connected to EARTH as indicated in the wiring diagram supplied with the control panel;
- The command and control circuits (24V) are galvanically separated from the electrical network as indicated in the electrical diagram supplied with the control panel;
- The safety circuit is galvanically separated from the electrical network as indicated in the electrical diagram supplied with the control panel.

MAINTENANCE

For the maintenance of the control panel, refer to the manuals provided with the control panel and check the status of the batteries of the alarm circuits and of the return to floor circuit (if present) during the periodic inspections of the system.

For the transport and handling of the control panel, refer to the instructions on the packaging.

Document References

Prepared by:	P. Vagnoni	01/2024
Checked by:	P. Vagnoni	01/2024
Approved by:	P. Vagnoni	01/2024

Changes to the document

Changes description	References
First Release	Rev 1.9
Second Release Hydro controller	Rev. 1.11

Summary

1.	Description of Junior 4.0 control board	7
1.1.	Main functions.....	7
1.2.	Specifications and descriptions of inputs and outputs.....	7
1.3.	Integrated Programming Module	7
1.4.	Remote programming module	7
1.5.	Fusion App.....	7
1.6.	Mother Board 4.0	9
1.6.1.	Controller power supply	10
1.6.2.	Encoder Position.....	10
1.6.3.	Relevelling Circuit	10
1.6.4.	Optional Board.....	11
1.6.5.	Emergency Circuit	11
1.6.6.	PME Panel	11
1.6.7.	Parallel Signal.....	11
1.6.8.	Batteries Test.....	11
1.6.9.	Output Spare	11
1.6.10.	Safety Chain	11
1.6.11.	Car at floor	11
1.6.12.	Hydro Command.....	12
1.7.	Firefighters maneuvers	12
1.8.	Oil / Motor Temperature Control	12
1.9.	Weight Load Control	12
1.10.	Door Command	12
1.11.	Protection Against Electrical Interference.....	12
2.	Main Connections and Temporary Operations	13
3.	Normal Service Mode.....	14
4.	Shaft Access	15
4.1.	Reduced Pit Configuration (option)	15
5.	Changing system parameters	16
5.	16	
5.1.	V3 Screen Menu map	16
5.2.	“System status” Menu	17
5.3.	“Faults” Menu.....	18
5.4.	Menu “I/O Status”	19
5.5.	“Configuration” Menu	22

5.6.	“Doors” Menu	23
5.7.	“Signals” Menu.....	24
5.8.	“Special Features” Menu	26
5.9.	“System Positioning” Menu.....	28
5.10.	“Rec Parameters” Menu	29
5.11.	“Clock” Menu	29
6.	Troubleshooting.....	31
	ANNEX II: Test and measures	42
	ANNEX III: Instructions for Software update	44
	PlayPad (PLP) SW update procedure	44
	Devices SW update procedure.....	45
	ANNEX VI: Emergency/Rescue Manoeuvres.....	47
	ANNEX VIII: UCM Circuit.....	48
	ANNEX IX: Installation Type	48
	ANNEX XI: Fire operation programming procedure	49
	Evacuation according to EN 81-73.....	49
	Annex XII: Timing Diagrams.....	51
	Hydraulic Lifts – Motor contactors	51
	Hydraulic Lift – Valves Contactors / Valve commands.....	52

1. Description of Junior 4.0 control board

The elevator control board Junior 4.0 is based on 32-bit electronic technology and operates all types of hydraulic lifts. Serial connections to floor and car panels may be added.

1.1. Main functions

- Control of any kind of hydraulic system
- Up to 7 floors
- CAN Bus serial line to connect display and serial Landing Operating Panels
- CAN Bus serial line for the serial car communication
- Types of control: SAPB, Constant pressure, Mixed manoeuvre
- Alternative or selective door control on through or adjacent access systems
- Lift position control by magnetic contacts
- Programming/diagnostic Interface, on board and/or remote
- Status diagnostic, errors, failures and I/O status
- Software upgrading via USB Device
- RS232 serial line for PC and GPRS modem connection
- Compatibility with all the +A3 solutions for electric and hydraulic systems
- Shaft access protection

1.2. Specifications and descriptions of inputs and outputs

The 4.0 Mother Board contains hardware and software that allows control of the elevator and all its peripherals. Through the integrated and/or remote programming modules it allows access to all available features. Inputs and outputs are connected to all electronic and electromechanical devices in the controller and in the lift.

1.3. Integrated Programming Module

The Mother Board has a removable programming module that allows viewing and editing of all the basic parameters for the management and configuration of the control panel.

For details of the programming module operation and an extensive management system menu, see paragraph 5 below (Changing Parameters).

1.4. Remote programming module

An alternative way to access the configuration menu of the controller, in the view/modification mode, is by connecting the removable keypad of the DMG V3 Playboard (PlayPad), to the connector PLP V3, mounted on the Lift Control Board.

1.5. Fusion App

An alternative way to access the controller is based on Fusion App.



1.6. Mother Board 4.0



M1 Power Supply

J16 Encoder Position

J9 Relevelling Circuit

J26 Optional Boards
J21 Emergency Circuit

J19 PME Panel

J6 Parallel Signals

LED 1

LED 2

LED 3

LED 4

LED 5

LED 6

J18 Env. Temperature

J12 Multiplex CAN

J10 Light Curtain / >|<

J8 UCM Circuit
J25 Batteries Test

J20 Out Spare
J11 Safety Chain

J4 FUJI Analog / Serial
J15 81-21 Circuit

J13 Car at floor
J14 Hydro command

J22 Motor Relay
J23 Brake Relay

FJ1 FUJI Interface

On mother board are present 6 leds for a easy diagnostic:

LED1: (Green led) not used.

LED2: (Green led) CAN Cabine termination active: led switch off when an optional board (PIT8 / 16IO / 16RL) is connected inside controller (termination automatically moves on last optional board).

LED3: (RGB led) color of this led gives info on the internal status of lift according following table:

COLOR	Status
Led off	The system is performing the reset procedure
GREEN	The system is in normal operation mode
YELLOW	The system is in inspection mode
PINK	The system is in temporary operations mode
PURPLE	The system is out of service (parking car)
CYAN	The system is running in priority mode (LOP / CAR)
RED	The system is operating in Fire-fighters mode
WHITE	The system is performing the emergency procedure
BLU	The system is performing the car drift control procedure

LED4: (Yellow led) led blinks when board is running.

LED5: (Green led) led on gives the status of SE5 safety chain

LED6: (Red led):

- Led OFF means no fault active.
- Led flashing means one (or more) fault active.
- Led ON means a locking fault active.

1.6.1. Controller power supply

Power supply from a commercial stabilized power supplier.

The negative terminal of the power circuits and the battery charger must be connected to the ground.

Internal Clock power supply: Super Capacitor (autonomy of 5 days without power supply).

1.6.2. Encoder Position

Not used.

1.6.3. Relevelling Circuit

Circuit to make Door Safety Contact Bypass for:

- Pre opening and/or
- Relevelling

The circuit management of the re-leveling operation consists of two Safety Relays.

- **ISO output (safety relay contact) open collector Max 24V 100mA**
- **Input CCISO (Monitor ISO safety relay) closure to GND (NC) I = 5mA**
- **Input TISO (Monitor Safty module) closure to GND (NC) I = 5mA**

1.6.4. Optional Board

Not used.

1.6.5. Emergency Circuit

Circuit for complete Emergency.

1.6.6. PME Panel

Connection to the Control Panel inside the cabinet.

1.6.7. Parallel Signal

Connection to the APPO Board. It includes all parallel signals available on the Cabinet's screw terminal.

1.6.8. Batteries Test

Connection to the CHAR Board. It includes the signals for

- Low Batteries;
- Phase sequence (only Hydro)
- Backup mode.

1.6.9. Output Spare

Generic Output used for special functions.

1.6.10. Safety Chain

Connection to the SECU Board. It includes the 7 points reading from the safety chain. The system is based on an opto insulated circuit connected to earth (Inside SEC Board):

- **Input SE0 ⇔ SE6 opto insulated 24 Vdc**

Above the safety circuit, a suitably sized magnetic circuit breaker($I_{max} = 0,5 A$) must be provided.

SE0 is the start point of Safety chain (after DIS Protection inside the controller)

SE1 controls SHAFT STOP zone and PIT Inspection Box

SE2 controls Top of car STOP and TOC Inspection Box

SE3 controls Limit Switches, Safety Gear, Overspeed Governor

SE4 controls FLOOR PRELIMINARY LOCKS

SE5 controls FLOOR LOCKS

SE6 controls CAR DOORS and Pre Triggered's contact systems

If the limit switch, or Overspeed governor or Safety Gear is activated (safety chain point SE3 opens), the system is set out of service.

To set it back in service you must reset the SE3 error via the programming module. Obviously the safety contact of the over run final limit switch must first be reset.

1.6.11. Car at floor

Signal output from Door zone sensor for luminous signal on cabinet.

1.6.12. Hydro Command

Connection to the COIL Board. It includes the moving commands for hydro installations. It can be used also in case of Remote Inverter installations.

1.7. Firefighters maneuvers

Possible use only for evacuation.

For further information on connections and parameters see ANNEX XI

1.8. Oil / Motor Temperature Control

In the event of the motor overheating, the contact opens and the lift is put out of service. Blocking of the lift can be immediate or when the call ends, depending on the setting.

1.9. Weight Load Control

When COM input is active, floor reservation calls are neither recorded nor managed.

When SUR input is active the car does not start and the acoustic signal in the car is activated. The SUR signal is ignored while driving.

1.10. Door Command

The door command board can command either one or two doors with alternative, selective or passage through opening. Output and inputs are available on the screw-terminal connectors on the JTOC board. The doors can be automatic, semi-automatic or manual:

DOOR A

- **M1 output (relay open/close door A) free contact max 24V 100mA**
- **Input BRO_A (A door opening button relay) closed to GND (NA) I = 5mA**

DOOR B

- **M2 output (relay open/close door B) free contact max 24V 100mA**
- **Input BRO_B (B door opening button relay) closing to GND (NA) I = 5mA**

1.11. Protection Against Electrical Interference

The boards has been designed to be protected against various types of interferences, following standard/normal requirements according to the requirements of the norm, against accidental mistakes and localization. Never the less we advise that the following rules are respected:

- Connect all metal masses to ground;
- Connect all unused conductors to ground (on the side of the cabinet);
- Connect the anti-noise filters delivered with the controller (inserted in the spare parts kit) in parallel to the brake coil (max 230VDC) and as close as possible to it;
- When a retiring ramp is present, connect the anti-noise diode delivered with the controller (spare parts kit) in parallel to the retiring ramp coil and as close as possible to it; make sure to connect the cathode (diode side marked with a white strip) to the power supply positive common "CAME+" and the anode to the negative "CAME-";
- For the wiring towards the car, if signals and 24V power supply wires are present in the same travelling cable, make sure these are kept apart (safety chain circuit, doors or retiring ramp power supply, 230V etc.).
- Always avoid placing signal cables in the vicinity of the power cables and / or power supply.

2. Main Connections and Temporary Operations

According to the "Temporary Operations" page of the electrical wiring diagrams schematic page:

- 1) Connect the main power supply
- 2) Connect the hydraulic pump motor
- 3) Connect the valves
- 4) Connect the Oil temperature sensor
- 5) Connect the inspection box for temporary operations
- 6) Switch on main power
- 7) Install the Electrical System (Quick Installation Guide)

3. Normal Service Mode

Once all above procedures are completed and the functioning of all signals has been verified, it is possible to put the system into Normal Service mode.

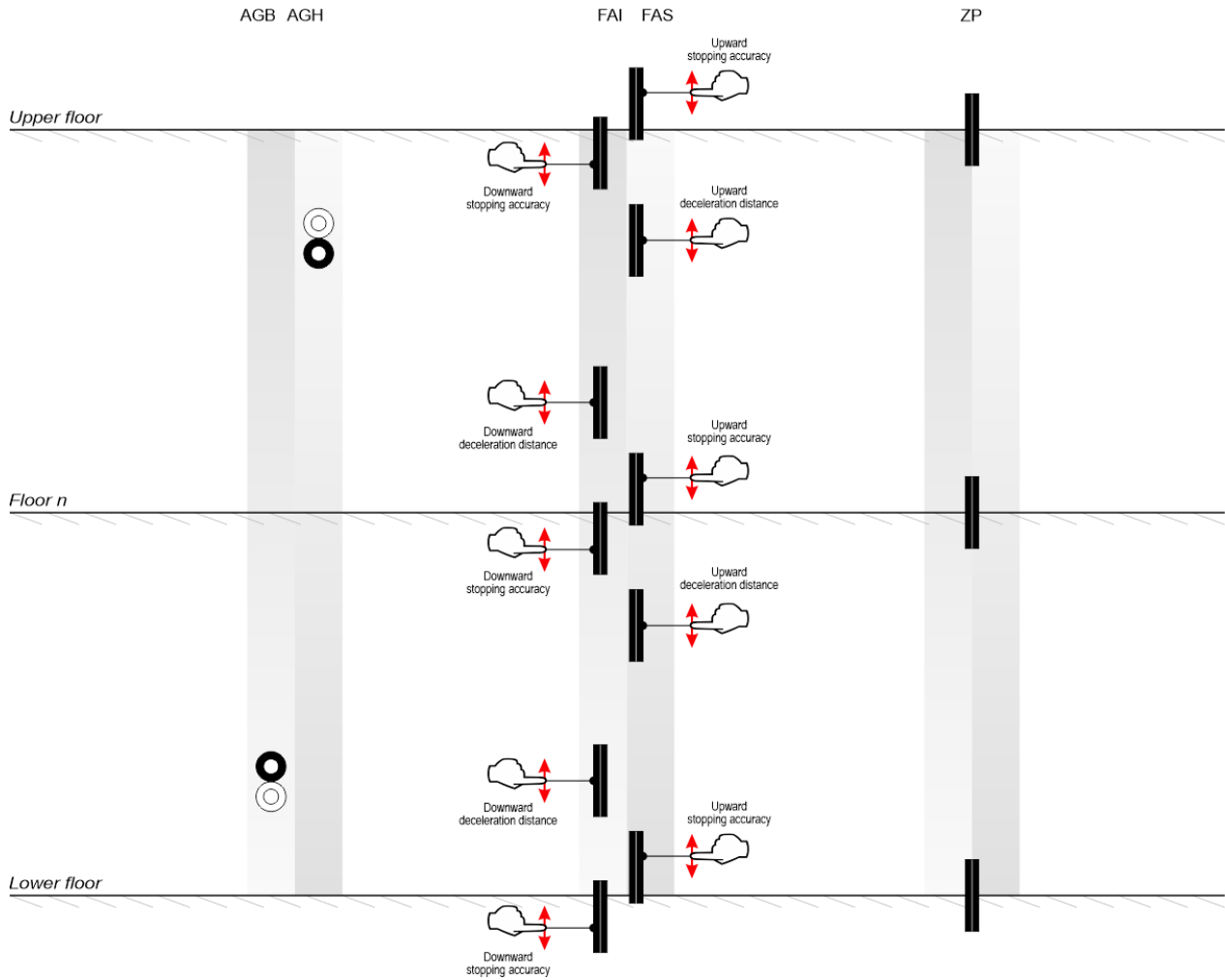

4. Shaft Access

Access to the shaft for systems requires that, after an access and subsequent exit from the lift shaft by an authorized person, there is a reset procedure that excludes the return to automatic operation of the lift. Below are the instructions for entering and exiting the shaft.

4.1.Reduced Pit Configuration (option)

Access in the pit

Access to the shaft is detected by opening a contact using the release key which activates the RSP fault (code 41), preventing the car from moving in normal operation (a run is only possible in 'Inspection' mode) Before entering the shaft, move the mechanical protection system in the safe condition.



After the end of Inspection operations the personnel must:

- Remove the manual protections and exit from the lift well;
- Close the landing doors (check the safety chain) and carry out the reset pressing the green button on the cabinet.

Characteristics of the auxiliary contact on door on the lowest floor:

- Monostable NC contact (does not open during normal door operation).

Key are electrically connected in series to the screw terminal of the controller.

Access on the Car roof No control required for access to the cabin roof.

Changing system parameters

5.1. V3 Screen Menu map

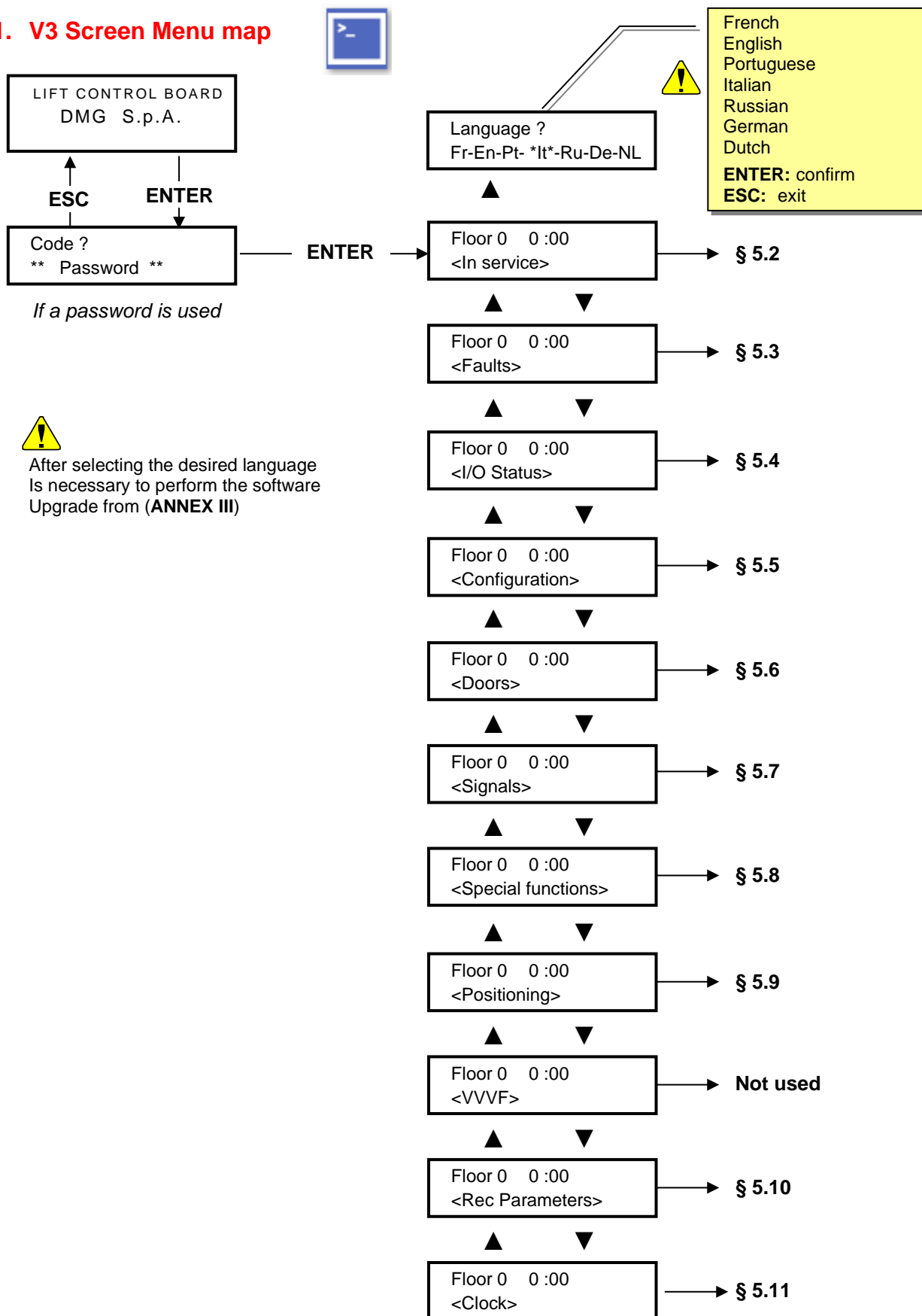

5.2. "System status" Menu

It is easily accessed from the main window of the PlayPad, by pressing once the ENTER key.

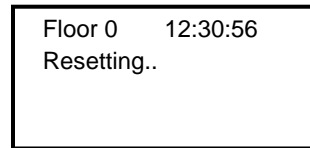

System Status	Description	Visualization on Serial display
Resetting	The system is performing the reset procedure	O -
In service	The system is in normal operation mode	
Inspection	The system is in inspection mode	OR
Temp. Operat.	The system is in temporary operations mode	P
Out of service	The system is out of service	
Car Priority	The system is running in car priority mode (priority key switch activated)	
Fire-fighters	The system is operating in Fire-fighters mode (various operations)	
Emergency	The system is performing the emergency procedure	E
Drift control	The system is performing the car drift control procedure	
Upward oper.	The system is running upwards	
Downward oper.	The system is running downwards	
Re-levelling	The car is at floor level and is re-levelling	
Still at floor	The car is at floor level, with no registered calls	
High speed	The system is running in high speed mode	
Low speed	The system is running in low speed mode	
Door close	The door is completely closed	
Door open	The door is opened (or opening/closing)	
Car full load	The car has been fully loaded	
Photocell A	The input relevant to the photocell entrance A is active	
Photocell B	The input relevant to the photocell entrance A is active	
BRA button A	The input relevant to the open door button of entrance A is active	
BRB button B	The input relevant to the open door button of entrance B is active	

5.3. "Faults" Menu

This Menu lists the last 60 faults stored into the internal memory of the controller. All faults are described in the Troubleshooting section (§ 6).

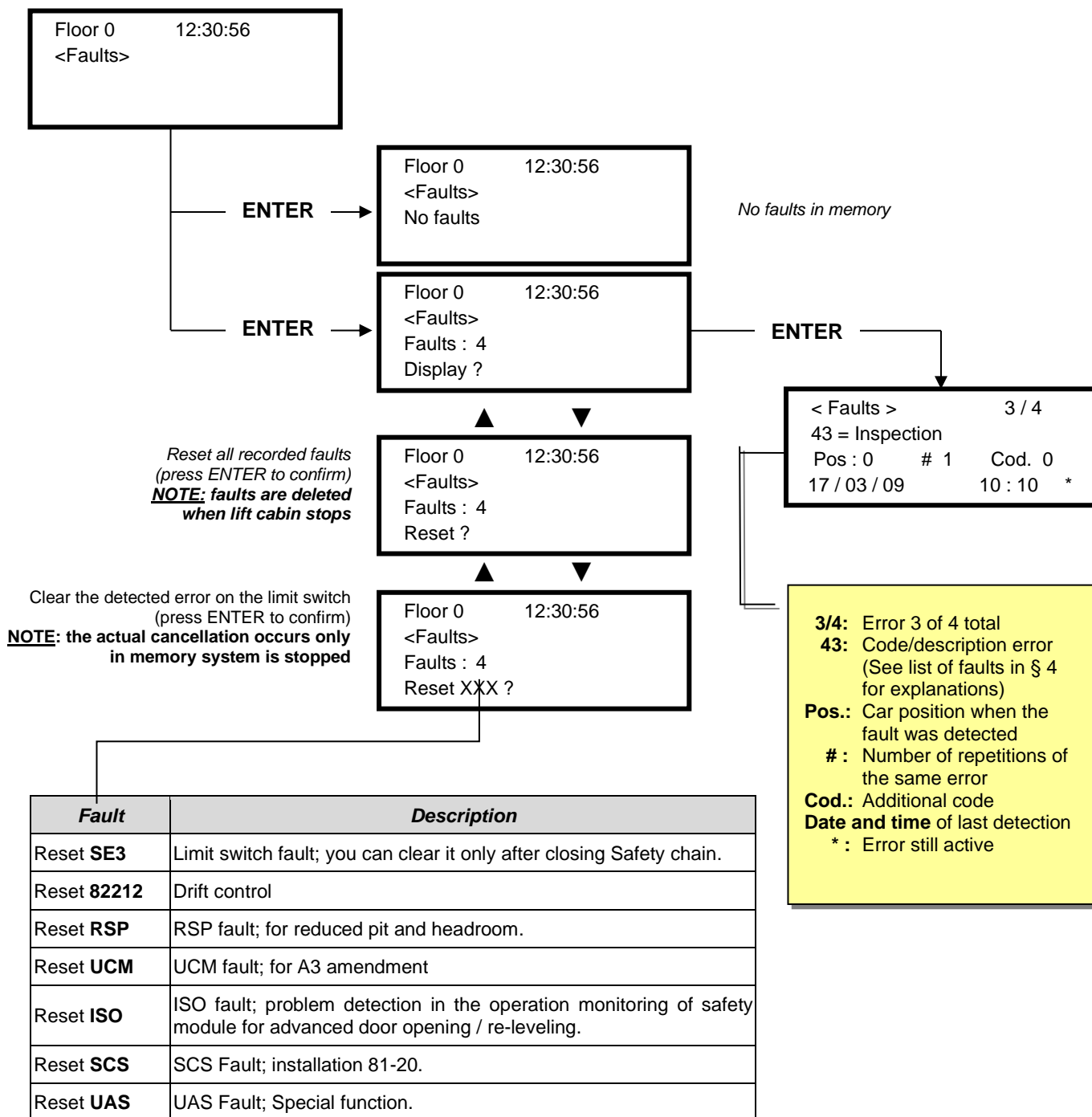

WARNING: In case of black out, the internal memory is saved only if the battery is connected.



5.4. Menu "I/O Status"



Table of Parameters

Field	Description	Navigation	Values (group of 12)				
Car call	Simulation of a car call	▲▼ Select floor ENTER Confirm ESC Exit					
 Playboard IN-OUT	System Inputs/Output <input type="checkbox"/> = Open contact <input checked="" type="checkbox"/> = Closed Contact	▲▼ Change group ENTER Exit ESC Exit	GROUPS				
			1/9	REM VHS SUR	RED TH1 COM	REV TH2 LE	REV1 REV2 LTMP
			2/9	RMO BRK RDE	RGV RMV RPV	MTR YBRK CCF	CCO CCOB
			3/9	BRA FOA ROA	CEA FFA RFA	BRB FOB ROB	CEB FFB RFB
			4/9	HS BFR OTM	PCA	POM RPH J20	CPOM IEME OEME
			5/9	FLM FLD	BIP GNGM GNGD	511B 511L	DSA 212B E511
			6/9	PWR ENAB	IN_A IN_D	BR1 BYPL	BR2 BYPC
			7/9	FAI ZP	FAS TISO	CAM ISO	AGH AGB CISO
			8/9	REM REM1 REM2	RED RED1 RED2	PME OVS	REV REV1 REV2
			9/9	L-RED L-GREEN BUZZER		GPIO1 GPIO2 GPIO3	
 Push buttons	Status of call buttons <input type="checkbox"/> = button not activated <input checked="" type="checkbox"/> = button activated	▲▼ Change group ◀▶ cab/down/up ENTER Exit ESC Exit	GROUPS				
			Cabin side A	7 3	6 2	5 1	4 0
			Cabin side B	7 3	6 2	5 1	4 0
			Pushb. Down side A	7 3	6 2	5 1	4 0
			Pushb. Down side B	7 3	6 2	5 1	4 0
			Upward side A	7 3	6 2	5 1	4 0
			Upward side B	7 3	6 2	5 1	4 0
Cards AUX	Cards AUX Inputs/Output <input type="checkbox"/> = Open contact <input checked="" type="checkbox"/> = Closed Contact (x.yz x=card, yz=contact on board)	▲▼ Change page ENTER Exit ESC Exit	CARDS 16 IO IN				
			1/12	1.08 1.04	1.07 1.03	1.06 1.02	1.05 1.01
			2/12	1.16 1.12	1.15 1.11	1.14 1.10	1.13 1.09
			3/12	2.08 2.04	2.07 2.03	2.06 2.02	2.05 2.01
			4/12	2.16 2.12	2.15 2.11	2.14 2.10	2.13 2.09
			CARDS 16 IO OUT				
			5/12	1.08 1.04	1.07 1.03	1.06 1.02	1.05 1.01
			6/12	1.16 1.12	1.15 1.11	1.14 1.10	1.13 1.09

			7/12	2.08	2.07	2.06	2.05
				2.04	2.03	2.02	2.01
			8/12	2.16	2.15	2.14	2.13
				2.12	2.11	2.10	2.09
			CARDS 16 RL				
			9/12	1.08	1.07	1.06	1.05
				1.04	1.03	1.02	1.01
			10/12	1.16	1.15	1.14	1.13
				1.12	1.11	1.10	1.09
			11/12	2.08	2.07	2.06	2.05
				2.04	2.03	2.02	2.01
			12/12	2.16	2.15	2.14	2.13
				2.12	2.11	2.10	2.09
BDU Inputs	BDU Inputs <input type="checkbox"/> = Open contact <input checked="" type="checkbox"/> = Closed Contact	▲▼ Change page ◀▶ Change group ENTER Exit ESC Exit	Group: Door, Fire, Key 1, Key 2, Key 3, Key 4. For each group, the status of the contact is displayed for each plan				
 Call registration list	Call registration list <input type="checkbox"/> = call not registered <input checked="" type="checkbox"/> = call registered	▲▼ Change group ◀▶ cab/down/up ENT/ESC Exit	Same Groups as PUSHBUTTONS				
[0] Start = ... [1] Start = ... [2] Start = ...	Run Counters [0] partial (resettable) [1] Total [2] Future use	◀▶ Change ENTER Reset and exit ESC Exit	Date showed is referred to the last reset of partial counter [0]				
Analogic	Analogic measures	◀▶ Change page ESC Exit	24 V = Power Supply VCAB = Cabinet anc Cabine absorptions VMR = BDU absorptions 24VB = Batteries Voltage +5.0 V = Board Internal power supply TAMB = Ambient temperature sensor PWM = Analogic speed output				
TOC Measures	Analogic measures	◀▶ Change page ESC Exit	T_SHA = Shaft temperature MAIN = TOC Power Supply COP_A = COP side A absorptions COP_B = COP side B absorptions				
COP Measures	Analogic measures	◀▶ Change page ESC Exit	MAIN_A = COP A power supply MAIN_B = COP B power supply T_CAR = Cabine temperature				
FLOORS Line	BDU Communication Line	ENTER Reset ESC Exit	Error: Communications error number FER: Frame Error Rate Date and hour of last reset				
CAR Line	TOC / COP Communication Line	ENTER Reset ESC Exit	Error: Communications error number FER: Frame Error Rate Date and hour of last reset				

PLAYBOARD IN-OUT table description parameters

Input	Description	Input	Description
SE0	Safety chain Start	REV	Inspection function (machine room)
		REV1	Inspection function (Top of Car)
		REV2	Inspection function (PIT)
SE1	Safety chain pit safety contacts	REM	Inspection up (machine room)
		REM1	Inspection up (Top of Car)
		REM2	Inspection up (PIT)
SE2	Safety chain top of car inspection Box/Stop	RED	Inspection down (machine room)
		RED1	Inspection down (Top of Car)
		RED2	Inspection down (PIT)
SE3	Safety chain final limit switch, safety gear, speed governor	TH1	Motor (Oil) temperature sensor control
		TH2	
SE4	Safety chain hall doors preliminary contacts	IEME	Emergency (power supply failure)
SE5	Safety chain hall doors inerlocks	PME	PME selector (emergency evacuation)
SE6	Safety chain car doors contacts and pre trigger device (81-21)	AGH	Top deceleration switch
		AGB	Bottom deceleration switch
CCO	power contactors control	FAS	Position Sensors (no encoder positioning system)
CCOB		FAI	
CISO	Monitor ISO relay	E511	Optional input for <i>Shaft Access</i>
TISO	Safety Module SM1 control	BYPL	Door's safety Bypass selector
		BYPC	
LE	Emergency Light (car light power supply)	BRA	Door open button (entrance A)
BFR	door close button	CEA	Photocell entrance A
PCA	car priority function	FOA	Door open limit switch entrance A
POM	Fire-fighters operations (Hall key switch)	FFA	Door close limit switch entrance A
CPOM	Fire-fighters operations (Car key switch)	BRB	Door open button (entrance B)
SUR	Overload control	CEB	Photocell entrance B
COM	Full load control	FOB	Door open limit switch entrance B
HS	out of service function	FFB	Fine corsa chiusura (Porta B)
ZP	door zone signal	BR1	Brake 1 monitor switch
RPH	Phase sequence control	BR2	Brake 2 monitor switch
		IN_A	Monitor UCM circuit
		IN_D	Monitor UCM circuit

Output	Description	Output	Description
VHS	Output - out of order illumination	DSA	Output - alarms de-activation
RMV	Output - intermediate speed command	511B	Output - Norm 511 Buzzer
BRK	Output - Brake command	511L	Output - Norm 511 Light
MTR	Output - Motor command	212B	Output - Norm 212 Buzzer
YBRK	Output - Brake command (VVVF)	FLD	Output - down arrows command
ISO	Output - Re-levelling command	FLM	Output - up arrows command
RGV	Output - high speed command	GNGD	Output - upward gong command
RPV	Output - low speed command	GNGM	Output - downward gong command
RMO	Output - up travel command	BIP	Output - BIP signalization in the cabin
RDE	Output - down travel command	PWR	UCM module power command
LTMP	Output - time limited car light command	ENAB	UCM module enabling command
CAM	Output - retiring ramp command	ROA	Output - door open command (entrance A)
OEM	Output - emergency command	RFA	Output - door close command (entrance A)
CCF	Output - Motor phase short Circuit	ROB	Output - door open command (entrance B)
		RFB	Output - door close command (entrance B)
		L-RED	Traffic Light signal 81-20/21
J20	Output - programmable (connector J20)	L-GREEN	Traffic Light signal 81-20/21
		BUZZER	Buzzer signal for bypass 81-20

5.5.

5.5. "Configuration" Menu

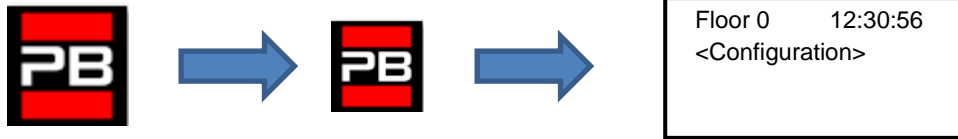

Table of Parameters

Parameter	Description	Navigation		Values	Default value
Temporary operations	Temporary operations mode of the system	◀▶	Choice	No; Yes	No
Test	To ease checks and installation start-up. For description, refer to Annex II.	▲▼			
Code ?	Password protection to access programming	◀▶ ▲▼	Change charact. Select charact.	8 characters (0 - 9; A - Z; a - z)	no password
Configuration	Type of wiring configuration: -) Standard wire terminals (Car and floors); -) Serial comm. in the car, 1 line/floor connectors at floors; -) Wire terminals in the car, Serial communication at floors (BDU modules); -) Serial communication for car and floors	◀▶	Choice	Car & Fl. STD; Car SER. / Fl. RJ45; Car STD. / Fl. BDU; Car SER. / Fl. BDU	Car SER / Fl. RJ45
Type of control	Type of control for the lift	◀▶	Choice	-SAPB; -SAPB constant pressure -constant pressure;	SAPB;
Drive	Traction type: -) Hydraulic – Motor Direct (Dir): can be used also in case of VVF activated only in UP direction	◀▶	Choice	Hydraulic Dir Hydraulic S-S Hydraulic Y-D Hydraulic VVF	
No. of floors	Number of floors of the installation	▲ ▼	Increase Decrease	2 <-> 7	2
Re-levelling	Not present: No Re-levelling Type 1: (open or close door). Re-levelling is triggered when the car leaves its position "perfectally at floor" that's to say when one of the two beams interrupted. Re-levelling ends when both beams are free. WARNING: this setting is not suitable for hydraulic installations due to the risk of "pumping" effect (car drifts down after stopping)	◀▶	Choice	Not present Type 1	Not present
Main floor	Position of the main floor (all calls below this floor are served only upwards (only down collective)	▲ ▼	Increase Decrease	0 <-> Floor No.	0
Low Speed fault time	Time before activation of the Low Speed fault (low speed too long)	▲ ▼	Increase Decrease	7 s <-> 40 s	7 s
Running time	Time before activation of running time fault	▲ ▼	Increase Decrease	20 s <-> 45 s	20 s

5.6. "Doors" Menu



Cod.	Parameter	Description	Navigation	Values	Default value
	Ret. ramp on	Time before activation of the retiring ramp (*)	▲ Increase ▼ Decrease	0,0 s <-> 9,9 s	0,1 s
	Ret. ramp off	Time before deactivation of the retiring ramp (*) When both ramp are 0 => bypass of fixed came.	▲ Increase ▼ Decrease	0,0 s <-> 9,9 s	0,1 s
	Lock fault time	Time before the activation of the lock fault	▲ Increase ▼ Decrease	2 s <-> 60 s	15 s
	Door open delay	Time before door opening – for automatic door	▲ Increase ▼ Decrease	0,1 s <-> 9,9 s	0,5 s
	Parking time with open door	Lift car parking time with open door (in sec.)	▲ Increase ▼ Decrease	1 s <-> 30 s	7 s
	Closing time with calls	Time (in sec.) before door closes in case of registered calls	▲ Increase ▼ Decrease	1 s <-> 60 s	2 s
	Doors Nb.	Number and type of doors	◀▶ Selection	-1 door -2 doors simult. -2 doors sel. -2 doors sel+through	1 access
	Type Door A	Selection of door type for entrance A: 1) <i>Manual / Not present</i> : manual doors at floors, car doors manual or not present; 2) <i>Car independent</i> : manual doors at floors, car doors independent; 3) <i>Car automatic</i> : manual doors at floors, car doors automatic; 4) <i>Combined auto</i> : automatic doors in the car and at floors	◀▶ Selection	Manual / not present; Car Independent; Car automatic; Combined Auto	Combined Auto
	Select door A at floor	Configuration of door A for each floor: set access to each floor and open or close door parking at floor (for automatic doors)	◀▶ Selection ▲▼ Change floor	No; Not enable Pkg. Door close; Pkg. Door open	Pkg. Door close;
	Door A Open/Close time	Door A without limit switch: door opening/closing time	▲ Increase ▼ Decrease	1 s <-> 60 s	10 s
	Door A start delay	Door A manual: time before start	▲ Increase ▼ Decrease	0,1 s <-> 9,9 s	2,0 s
	Door A powered	Door A powered during the run. Not considered for manual or independent doors	◀▶ Selection	No Yes Yes AT40	No
	Type Door B	Selection of door type for entrance B (see Type Door A):	◀▶ Selection	see Type Door A	Combined Auto
	Select door B at floor	Configuration of door A for each floor: set access to each floor and open or close door parking at floor (for automatic doors)	◀▶ Selection ▲▼ Change floor	No; Not enable; Pkg. Door close; Pkg. Door open	Pkg. Door close
	Door B Open/Close time	Door B without limit switch: door opening/closing time	▲ Increase ▼ Decrease	1 s <-> 60 s	10 s
	Door B start delay	Door B manual: time before start	▲ Increase ▼ Decrease	0,1 s <-> 9,9 s	2,0 s
	Door B powered	Door B powered during the run. Not considered for manual or independent doors	◀▶ Selection	No Yes Yes AT40	No
	Advanced opening	Parameter for door advanced opening (opening starts before car stop).	◀▶ Selection	No; Yes	No

Cod.	Parameter	Description	Navigation	Values	Default value
	Doors Contact time	Waiting Time before start a trip (for old door's safety contact)	▲ Increase ▼ Decrease	0,0 s <-> 3,0 s	0,1 s

5.7. "Signals" Menu



Cod.	Parameter	Description	Navigation	Values	Default value
	Car priority	Time of car at floor without direction before taking landing calls. In case of combined automatic doors, timing starts when doors have closed and the shock, photocell and re-opening contacts are not activated	▲ Increase ▼ Decrease	2 s <-> 30 s	10 s
	Floor call registration	Set the blinking for floor buttons upon registration	◀▶ Selection	Permanent; Flashing at floor	Permanent
	AUX output	Selection of the output type on the 16 relays boards. NOTE: 1 wire/floor and 1 wire/floor HYD configurations are available only on first 16RL board. After the two AUX board configuration can be set the outputs on BDUs (OUT-1 and OUT-2).	◀▶ Selection Tasti su e giù	1 wire per floor; Car at floor; Floor light; Gray indicator; 9 segm. indicator; Lift is coming	1 wire per floor
		BDU Inputs Type 0 = Car at floor and Out of Service Type 1 = Arrows Type 2 = Car at floor and Car is coming Type 3 = 3 Wire Display The first setting s for all floors, the second setting can be used for specific configuration floor by floor. The BDU dynamic output is used also in case of PIT8 boards (parallel pre wired LOPs).		1 wire per floor HYD;	Type 0
	Automatic floor designation	Automatic setting of numeric characters for serial position indicators. The value increases/decreases automatically at each floor starting from Lowest floor	▲ Increase ▼ Decrease	-9 <-> 30	Lowest fl.: 0
	Manual floor designation	Manual setting of alphanumeric characters for serial position indicators. Setting must be done for each floor	◀▶ Field Selection ▲▼ Change value	- ; 0 <-> 9 ; A <-> Z	
	Trigger on PV	It is possible to start trigger (speech synthesiser / next direction arrows) on deceleration point (Yes) or to floor arrival (No).	◀▶ Selection	No yes	No
	Next direction arrows	In case of parameter activation, arrow outputs are activated only when lift stops at floor (or on slowing down if trigger parameter on PV is active).	◀▶ Choice	No; Yes	No
	LTMP Delay	This function handle the delay between a floor/car call and the light turning on. The output is deactivated XX seconds after the call has been served. 0 sec means no timer active (light ON)	▲ Increase ▼ Decrease	0 s <-> 240 s	1 sec.
	EME Delay	This function handles the delay between the black out signal (IEME) and output command (OEME) before system switch in automatic emergency procedure.	▲ Increase ▼ Decrease	0 s <-> 30 s	0 sec.

Cod.	Parameter	Description	Navigation	Values	Default value
	Buzzer 81-21	For 81-21 installation: use the 81-20's acoustic buzzer (bypass door) on the top of car as acoustic alarm when protections are not in active position.	◀▶ Choice	No; yes	No

5.8. "Special Features" Menu



Table of Parameters

Parameter	Description	Navigation	Values	Default value
Reset in	Direction of travel during reset procedure	◀▶ Selection	Down; Up	Down
Travelling limits in inspection	Valid only for FAI/FAS positioning system. Settings for the travelling limits during inspection mode. If travelling is programmed beyond the limits, the controller does not allow any movement beyond top/bottom floors.	◀▶ Selection	Up to AGB/AGH; Beyond AGB/AGH	Up to AGB/AGH
Fire-fighters	(Refer to Annex XI - Fire operation programming procedure) Type of fire-fighter operations (if present) and relevant parameters (fire service access level and side, POM and CPOM key contact type); choice of relevant applicable norm: - Norm NF P82-207 (France); - EN 81-72 (a): no car FF key switch; - EN 81-72 (b): with car FF key switch;	◀▶ Select field ▲▼ Change value	Not present; NF P82-207; EN 81-72 (a); EN 81-72 (b); EN 81-73 DM 15/09/2005 (IT)	Not present
Fire detection	Parameter for fire detection at floors. - if the lift is at a different floor than the one where fire was detected, all registered calls from/to this floor are cancelled; - if the lift is at the floor where fire was detected, the controller blocks door opening, closes doors (if open upon fire detection) and sends the car to a safe floor	◀▶ Selection	No; Yes NO Yes NC	No
Stop button registration	The system registers the out of service mode (pressure of STOP button). It is also possible to set the delay to avoid simultaneous movement in installations powered with a generator.	◀▶ Selection	No; Yes	No
EN 81-20	System setting according to EN 81-20	◀▶ Selection	No; Yes	No
Anti-nuisance fault	Parameter for the detection of the anti-nuisance fault (number of stops without photocell activation after which all car calls are cancelled)	◀▶ Selection ▲▼ No. calls	No; Yes 2 <-> 10	No 3
Out of service floor	Floor for out of service. Parking floor when HS input is enabled.	▲ Increase ▼ Decrease	0 <-> Floor No.:	0
Automatic return	Parameters for car automatic return at floor: Return floor and Minimum waiting time before automatic return	◀▶ Select parameter ▲▼ Change value	No 0 <-> Floor No.: 1 min <-> 60 min	No 0 15 min.
Return zones	Advanced settings for return at floor at planned hours / days: - Day (0 = everyday, 1 = monday ... 7 = sunday); - Selected time interval (4 interval each day); - Return floor; - Start time; - End time (max time: 7h 45 min);	◀▶ Select parameter ▲▼ Change value		
R. zone timing	Timing for selected return zones	◀▶ Selection ▲▼ Change Value	No; Yes 1 s <-> 120 s	No 60 s
Call erasing at floor	Erasing all calls at floor where the car stops, with no control of the direction (only for full collective installations)	◀▶ Selection	No; Yes	No
Drift control (FR)	Drift control (France)	◀▶ Selection	None; Traction drive; Drum machine	None
Push-button code	It allows you to program a 4-digit code for Car calls. A 4-digit code may be assigned to each BCx car button input, corresponding to the car pushbutton inputs.	◀▶ Select field ▲▼ Change value		

Parameter	Description	Navigation	Values	Default value
	<p>Example: if the BC0 pushbutton is associated with the 0123 code, to reserv floor 0 from Cabin you can:</p> <ol style="list-style-type: none"> a) keep pressed the floor 0 pushbutton for 3 seconds. b) All COP pushbutton will blink c) Press in sequence the pushbuttons corresponding to the BC0, BC1, BC2, BC3; <p><i>Note:</i> Enter a code between 0 and 9 corresponding to the inputs BC0 ÷ BC9</p> <p>Programming Code "0 _ _" will enable the special function Pent House</p>			
Controle Temperature ambient	<p>Check the temperature in the engine room through the sensor (if present). If the temperature surpass the set thresholds for more than 30 seconds, the system stops at the floor and the error is recorded. The control is only active during normal operation or Cabin priority. After having set the two thresholds, pressing Enter you can perform the sensor calibration (immediately press Enter to retain the current calibration, otherwise set the room temperature value and then press Enter). The first threshold can be set between -10 ° C and +5 ° C while the second threshold can be set between +40 ° C and +75 ° C.</p>	<p>◀▶ Select field ▲▼ Change value</p>	Without; +5°C <=> +40°C	Without
Automatic Calls	<p>When lift is in normal mode, "Automatic calls" can be activated to perform a specific calls number (up to 120 calls or unlimited) in steps of one minute. However is possible to enable or not the doors functionality (the system will also continue to accept floor calls simulating programmed calls, if enabled). The function ends automatically when the machineries are turned off or if the system is put in inspection mode.</p>	<p>▲▼ Increase Decrease ◀▶ Select Doors</p>	<p>0 <-> 120 ∞ 10 <-> 60 s Yes - No</p>	<p>0 60 s Yes</p>
Monitor UCM	<p>A3 amendment. Configure type of monitor. For description, refer to Annex VIII.</p>	<p>▲ Increase ▼ Decrease ◀▶ Choice</p>		
UCM	<p>Installation type 81-1 / 81-20 / 81-21 Shaft access procedure and Protections. For description, refer to Annex IX.</p>	<p>▲ Increase ▼ Decrease ◀▶ Choice</p>		
Forced Stop	<p>If programmed, the installation will stop at a specific floor at each crossing (some hotels use this function).</p>	<p>▲ Increase ▼ Decrease ◀▶ Choice</p>		
Protect floor	<p>If a protected floor is programmed, when the car reaches the floor, the door does not open, instead the monitor will show images coming from the camera corresponding to that floor. Doors can be opened only by pressing the OPEN DOOR button; if this does not happen, the lift moves to the previous floor and then stops the protected floor mode (this operating mode is only possible with DMG's monitoring system).</p>	<p>▲ Increase ▼ Decrease ◀▶ Choice</p>		
Lop priority	<p>Enabling the floor priority call function. pairing with 16 IN card (or key inputs from BDU)</p>	<p>◀▶ Choice</p>	No; Yes	No

File Name

Revision Date

Page

93010349.EN_A_Junior 4.0 User Manual_240125_v1.11 - Hydro.docx

1.11 25/01/2024

27 / 54

5.9. "System Positioning" Menu



Table of Parameters (FAI / FAS positioning system)

Cod.	Parameter	Description	Navigation	Values	Default values
	Positioning system	Type of positioning system: with Encoder or traditional. Can only be modified in Temporary Oper. Mode Note: in case of absolute Encoder and shaft lengths longer than 65 meters change the resolution of Encoder = 2 in autsetting menu before starts the Manual teach procedure.	◀▶ Selection	FAI/FAS; Encoder Clockwise; Encoder Counter clockwise Encoder ELGO	FAI/FAS
	Top PV	Position of the deceleration (passage in Low Speed) and number of entrances	▲ Increase ▼ Decrease	2 <-> 6	5
	PV at floors	Position of the specific deceleration for each floor	◀▶ Top PV ▲▼ Floor choice	Short floor or 2<->6 0 <-> No. Floor	5 all floors
	Short level delay	Time before short level deceleration (only if a short level is programmed)	▲ Increase ▼ Decrease	0,00 s <-> 2,50 s	0,00s
	Top PV 2 Delay	Delay before passage to Intermediate speed	▲ Increase ▼ Decrease	0,00 s <-> 2,50 s	0,00 s
	Delay Dir.-BRK	VVVF: Delay between activation of travel direction and run command (BRK)	▲ Increase ▼ Decrease	0,0 s <-> 3,0 s	0,5 s - VVVF 0,0 s - Others
		OLEO: Star / Delta delay	▲ Increase ▼ Decrease	0,0 s <-> 3,0 s	0,5 s - VVVF 0,5 s - Star/Delta 0,0 s - Others
	Delay BRK-S	Delay between activation of BRK command and speed command	▲ increase ▼ decrease	0,0 s <-> 3,0 s	0,00 s
	Delay BRK-Dir.	Delay between deactivation of run command and deactivation of travel direction (arrive al piano)	▲ Increase ▼ Decrease	0,0 s <-> 3,0 s	1,5 s - VVVF 0,0 s - Others
	Inspection speed	Sets the speed of travel in inspection	◀▶ Selection	Low speed; High speed	Low speed
	Emergency BRK On	Emergency break modulation parameter (modify only if EME board is not present)	▲ increase ▼ decrease	0,0 s <-> 5,0 s	0,0s
	Emergency BRK Off	Emergency break modulation parameter (modify only if EME board is not present)	▲ increase ▼ decrease	0,0 s <-> 5,0 s	0,0s

NOTE: Please consult the time diagram at the end of this manual, to better understand some parameter meanings.

5.10. "Rec Parameters" Menu

Note: data saving is not required only for emulation of PBV3 controllers.

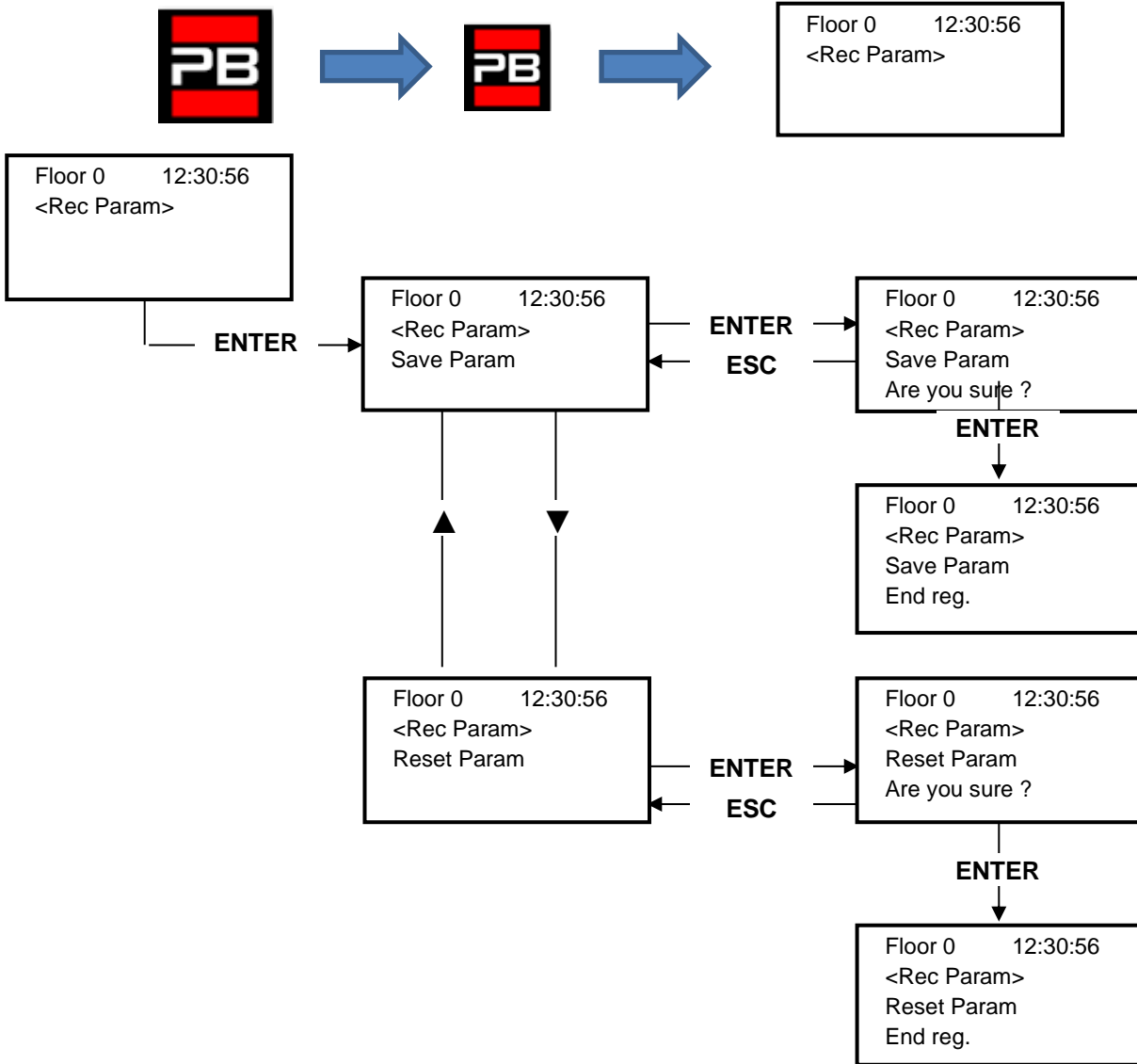

5.11. "Clock" Menu



Da = Day
Mo = Month
Yr = Year
D = Weekday (1=Mon)
Hr = Hours
Mn = Minutes

WARNING: In case of system shutdown, the time is saved by means of a Super Capacitor (for up to 5 days without power supply).

6. Troubleshooting



N.	Fault	Type	Description	Remedy
1	Reset		<p>Power supply: the controller was restarted. For informational purpose only.</p> <p>Furthermore, if there are devices that require a restart, it can present itself with the following specific codes: Cod 9: 9 months without power cycle reset, lift continues to operate. Cod 12: 12 months without power cycle reset, lift is out of service. Must be executed a POWER restart</p>	<p>Cod 9 / 12 are present only in case of LM2 inverter or LIMAX3CP. Power restart is requested from these devices.</p>
2	Contactors blocked		<p>One or more NC contacts associated to the power contactors and connected in series on the input CCO and CCOB remain open after the car stop. Cod 0: CCO open Cod 1: CCOB open Cod 2: CCO+CCOB open</p>	<p>Check:</p> <ol style="list-style-type: none"> 1- the series of auxiliary contacts (NC) of the power contactors and other cables in series on the circuit CCO and CCOB 2- the CCO and CCOB circuit wiring 3- the connection of the CCO and CCOB on the board
3	Low speed too long		<p>Car moving at low speed for too long. In case of VVVF may be too low engine torque in the approaching floor phase.</p>	<p>Check:</p> <ol style="list-style-type: none"> 1- Check parameter "Low Speed fault time" (§ 5.5) and increase time if necessary 2- the elevator speed to a low speed (in the case of VVVF); increase it if necessary 3a- the decelerating distance to the plane indicated (magnets FAI / FAS) 3B- value of the distance R1D / R1S if Encoder is used (§ 5.9)
4	Overload		<p>Overload input (SUR) activated (NO contact)</p>	<p>Check</p> <ol style="list-style-type: none"> 1- the SUR input (if locked) and wiring 2- the setting of the load weighing device
5	Positioning fault		<p>This error shows a difference between the performed theoretical counting and the real position detected:</p> <p>Cod 0: at the activation of the AGB/AGH limit contacts; Cod 100: at the activation of ZP magnet floor Cod 200: at the activation of stop level's ZP magnet floor</p>	<p>Check:</p> <ol style="list-style-type: none"> 1- the correct positioning of the magnets (or flags) 2- operation of magnetic reeds or encoder; verify the arrival of 24V current 3- the distance between extreme contact and magnet
6	Direction fault		<p>The controller detects the wrong direction of travel</p>	<p>Check:</p> <ol style="list-style-type: none"> 1- the direction of travel of the engine (control UP vs. Car movement direction) 2- the installation and connection of FAI / FAS sensors 3- CW / CCW Encoder configuration (§ 5.9) 4- AGH and AGB inputs

N.	Fault	Type	Description	Remedy
7	Safety 3 open at stop		Safety chain interrupted with elevator not running. Calls are deleted. On the PlayPad Led SE3 is off.	Check all contacts between the terminals SC2 and SE3 (Safety Gear, Limit switch, Overspeed Governor).
9	Door lock fault		Safety chain open at point SE6 when a call is registered <i>With automatic door:</i> door re-opens and then closes (3 times, after which all calls are cancelled). <i>Other door types:</i> after a few seconds all calls are cancelled Cod 5: floor locks Cod 6: car door	Check all contacts between the terminals SD2 and SD3 (floor locks) or SC4 and SC5 (car doors) according cod info, their connection and if an object obstructs the closing of the door to the indicated floor (POS). In case of 81-21 devices check its contacts in Normal mode operations.
10	Door A opening slippage		Only doors with limit switch: door does not open within the planned time. In case of slippage during door opening, the door is considered open	Check: 1- Door open limit switch (FOA) and its wiring; 2- door operator power supply and fuses; 3- door open contactors (ROA)
11	Door B opening slippage		Same as door A, for second entrance	Same as A, but signals (FOB) and (ROB).
12	Safety 3 open during travel		Safety chain open before Input SE3 while car travelling. Car stops and car calls are cancelled. On the PlayPad Led SE3 is off.	Check all contacts between the terminals S35-S36 (Top of Car) SC3-SM4 (controller) Safety devices: Safety Gear, Limit switch, Overspeed Governor.
13	Motor temperature sensor		Inputs TH1 or TH2 of motor temperature is activated (NC contact) Cod 1: TH1 open Cod 2: TH2 open Cod 3: TH1 and TH2 open Cod 10: Door's thermic input (TOC board)	Check inputs (TH1, TH2), sensor connections and the state of the motor's temperature sensor. Cod 1 Check TH1 input Cod 2 Check TH2 input Cod 3 Check TH1 and TH2 inputs Cod 10 Check door's thermic input on TOC board's M16 Connector.
14	Parameters memory		Fault in the Eprom parameters memory	Reset, re-enter and record all parameters
15	Final limit switch		When it is reached the final limit switch (or Safety Gear or Overspeed Governor limiter trip), the input SE3 is active (NC contact). After delay of 1,5 s the error remains in memory, even after deactivation of the signal, and inhibits the landing calls and the car movements, until special reset Menu "Errors" is made (Reset SE3).	1- Release the final limit switch (or Safety Gear or OSG) closing the safety chain (SE3) and cancel fault in the "Error" Menu (§ 5.3). 2- Check the connection of the NC contact between SC2 and SE3 terminals
16	Fire detection.		In case of fire sensors installed, this fault indicates that one or more sensors are active	Check fire sensor input(s)

N.	Fault	Type	Description	Remedy
17	Safety 4 open during travel		Safety chain open before input SE4 while car travelling. Landing calls and the car movements are cancelled On the PlayPad Led SE4 is off.	Check all contacts between the terminals SD1 and SD2 (Preliminaries floor doors).
18	Safety 6 open during travel		Safety chain open before Input SE6 while car travelling. landing calls and the car movements are cancelled On the PlayPad Led SE6 is off. Cod 5: floor locks Cod 6: car door	Check all contacts between the terminals SD2 and SD3 (floor locks). Check all contacts between the terminals SC4 and SC5 (car door). Check all contacts between the terminals SC5 and SE6 (Protection device 81-21).
19	Low tension during movement		Motherboard power below 17V (this fault disappears when the 24V is restored) Cod 0: Main power Input Cod 1: Overcurrent on VCAB Cod 2: Overcurrent on VMR Cod 3: Short Circuit on VCAB Cod 4: Short Circuit on VMR Cod 230: Missing 230 V, controller is powered with batteries	Check the network, the supply voltage to the transformer primary, the presence of 24V and the consumption of the circuit. Cod 230 check backup circuit (R230) if present or shunt on J8 of CHAR board.
20	Travel interrupted		During upward (or downward) movements contactors open while RMO (or RDE) commands are active. Possible short interruption of the safety circuit while moving. Cod 100: CCO signal falling during travel Cod 200: CCOB signal falling during travel	Check: 1- Preliminary contacts and door lockers at the indicated floor 2- car door contacts 3- the supply voltage of the safety circuit
21	CCO input blocked		The contactors control circuit (Input CCO) remains closed after travel command is given Cod 100: CCO Cod 200: CCOB Cod 250: CTB not activated	check: 1- wiring and state of the auxiliary contacts (NC) of the power contactors and other NC contacts wired in series on the CCO / CCOB circuit 2- CCO / CCOB Motherboard input
22	Low tension at stop		Same as Fault N.19 Cod 0: Main power Input Cod 1: Overcurrent on VCAB Cod 2: Overcurrent on VMR Cod 3: Short Circuit on VCAB Cod 4: Short Circuit on VMR Cod 230: Missing 230 V, controller is powered with batteries	Check the network, the supply voltage to the transformer primary, the presence of 24V and the consumption of the circuit. Cod 230 check backup circuit (R230) if present or shunt on J8 of CHAR board.
23	AGB blocked		The expected operation of AGB (NC) contact is not checked. Cod 100: contact is not closed at floor different from bottom floor (downward calls erased). Cod 200: contact is not open at lowest floor (lift locked)	Check the condition of the contact AGB (mechanical switch or magnetic sensor) and the AGB circuit wiring

N.	Fault	Type	Description	Remedy
24	AGH blocked		The expected operation of AGH (NC) contact is not checked. Cod 100: contact is not closed at floor different from top floor (upward calls erased). Cod 200: contact is not open at top floor (lift locked)	As for the error 23, regarding the AGH input
25	AGH and AGB simultaneously		Inputs AGB / AGH opened simultaneously. The system shuts down.	Check the condition of AGH and AGB contacts (mechanical or magnetic) and their wiring. When one of the two contacts is closed, the system performs a reset manoeuvre.
26	Running time UP		No change in the beam status for motion sensors (or floor) for more than planned during car travel. In case of encodeur the threshold is 1 sec. over AGB/AGH limit point Cod 0: problem on FAI FAS input (no changing of inputs for time longer than "Running time" parameter Cod 100: problem on encoder channel Cod 200: no changing of ZP input for time longer than "Running time" parameter	Check contactors, brake, motor power supply, FAI/FAS sensors (or ENCODER). Check "X1" and "12" inputs of the VVVF. Anti-slippage test: See Annex II – Test and measures
27	Running time DOWN		See above but in downward movement	See above but in downward movement
28	Door A closing slippage		Only doors with limit switch: Door A does not close within programmed time. 3 complete opening/closing cycles are performed, then all registered calls are cancelled	Check: 1- door close limit switch FFA (NC contact) and wiring 2- door motor power supply and fuses 3- door close contactors (RFA)
29	Door B closing slippage		Same as door A, for second entrance	Same as door A, but signals (FFB) and (RFB)
30	Out of service switch		If the relevant parameter has been programmed, it indicates that the system has been put out of service through the activation of input HS Cod 0: Key HS activation Cod 100: BDU's key activation. Cod 200: cabine key activation.	Check input out of service input (NO contact) Cod 0: input HS on screw terminal Cod 100: input IN 2 on BDU Cod 200: input SPARE on DMCPIT
31	FAI-FAS error		Simultaneous variation of FAI/FAS positioning sensors. POS [n] indicates that the error occurred at floor [n]. POS 100 indicates a wrong sequence of beams	Check power supply to sensors; Check sensors and magnets position.
32	Temporary op. without insp.		During temporary operations the input REV or REV1 or REV2 must be active or the lift will not move.	Check input REV, REV1 or REV2 (NC contact)

N.	Fault	Type	Description	Remedy
33	Stopping accuracy		When the lift stops at floor, the two FAI/FAS LEDs are on. If within 2 seconds from the stop one of the beams is interrupted, this fault occurs. If the system is equipped with ENCODER the uncertainty of the stop is more than 2 cm.	Check: 1- position of the magnets; 2- deceleration distances; 3- motor brake
34	Anti-nuisance		It appears after a call cancellation and if the parameter "Anti-nuisance" has been programmed. The reason is too many calls from the car without the cell being cut (in case of combined doors) or without landing doors opening (other door types)	Change number of unwanted calls in the Anti-nuisance parameter
35	Lift not available		The lift cannot take calls and is not considered for call dispatching (in multiplex). After 3 closing door cycles, the lift is considered unavailable for 1 minute. Cod 10: No power on Car light Only in multiplex: Cod 100: light curtain / door open button Cod 200: no SE4 signal (eg manual door not closed)	
36	Phase sequence		Wrong sequence in input phases. Could be detected even during system shutdown	Check the right sequence of phases or swap two phases on power input terminals L1-L2-L3
37	Low battery		Low charge on 24V battery	Test battery charge or change battery
38	SE2 open		Safety chain open. Landing calls and the car movements are cancelled. Playpad SE2 led is off. Cod 0: DIS switch open (SE0 led off) Cod 1: PIT safety circuit open (SE1 led off) Cod 2: TOC safety circuit open (SE2 led off).	Check DIS Switch Check all contacts between the terminals SP3 and SP4 (STOP in the pit, pit ladder, Inspection box, etc.). Check all contacts between the terminals SC1 and SC2 (STOP on the Toc, Toc protection, Inspection box, etc).
39	Ambient temperature		This error indicates that the ambient temperature detected by the sensor is outside the set limits. Cod 100: Temperature below the lower threshold; Cod 200: temperatures above the higher threshold.	1 - Check the presence and connection of the temperature sensor. 2- Control activation, the threshold adjustment and sensor calibration can be made in the Special Features menu.

N.	Fault	Type	Description	Remedy
40	Fault RSP		<p>For reduced pit and headroom.</p> <p>Cod 20: pit access according EN81.20</p> <p>Cod 21 shaft access according EN81.21</p> <p>Cod 41: Fake pit access according EN81.41</p> <p>Cod 111: Monitor Relay RSDC fail (contact doesn't open)</p> <p>Cod 121: reset circuit bi stable contact EN81.21 (automatic reset)</p> <p>Cod 131: Bistabile circuit (relay RSR1)</p> <p>Cod 132: Bistabile circuit (relay RSR2)</p>	<p>Clear RSP parameter in the menu Faults (§ 5.3)</p> <p>Cod 111 check right working of relay RSDC</p> <p>Cod41 (Junior): the fault reset itself automatically after restoring the fake pit circuit (input E511 closed)</p> <p>Cod. 121: check reset circuit. It could be possible automatic reset of bi stable contacts caused by problem on reset circuit. The contact series must be open and then make a standard reset.</p> <p>Cod 131 (132) check right working of relsy RSR1 (RSR2) and after make the Reset procedure.</p>
41	Fault ISO		<p>Problem detected in the operation monitoring of safety module for advanced door opening / re-leveling. If activated, the installation goes into "out of service" mode at the top floor (electric) or bottom floor (hydro).</p> <p>Cod. 10: Monitor Relay RISO fail</p> <p>Cod 100: fail on Safety module monitor during travel</p> <p>Cod 200: fail on Safety module monitor at level</p>	<p>Check the alignment of ISO1 and ISO2. Reset ISO in the menu Faults (§ 5.3).</p>
42	TOC Communication		<p>No serial link between controller and car (in case of car serial link system configuration)</p>	<p>Check CAN link between controller and top of car board</p>

N.	Fault	Type	Description	Remedy
43	Inspection		<p>The system is in Inspection mode (NORM/ISP switch set to Inspection)</p> <p>EN 81.1/2 Cod 1: REV input open (STD Version) Cod 2: TOC's REV1 input open Cod 3: REV + TOC's REV1 input open Cod 5: REV input open (Pitagora version) Cod 6: REV1 input open Cod 7: REV + TOC's REV1 input open</p> <p>EN 81.20 Cod 11: PME inspection (REV) Cod 12: TOC inspection (REV1) Cod 13: PME + TOC inspection (REV + REV1) Cod 14: PIT Inspection (REV2) Cod 15: PME + PIT Inspection (REV + REV2) Cod 16: TOC + PIT Inspection (REV1 + REV2) Cod 17: PME + TOC + PIT Inspection (REV + REV1 + REV2)</p>	<p>To exit the inspection mode move the NORM/ISP switch to Normal and close the safety chain to trigger the reset procedure</p>
44	Re-levelling not completed		<p>Hydraulic lifts: the re-levelling procedure was not completed within 10 seconds. All subsequent re-levelling requests at the same floor are inhibited</p>	<p>Check:</p> <ol style="list-style-type: none"> 1- the correct operation of the Safety module and of its sensors ZP1 and ZP2; 2- Check the FAI/FAS or ENCODER sensors and the ZP sensor; 3- position of the magnets in the re-levelling zone; 4- RISO relay.
45	Fault ZP		<p>Door zone contact stays open when the sensor is in door zone position</p>	<p>Check the correct operation of the door zone sensor (if present); See Fault # 33</p>
47	Faults memory		<p>Errors in the faults memory</p>	<p>Erase all faults</p>

N.	Fault	Type	Description	Remedy
48	BDU link unavailable		<p>In case of serial communication with floors, indicates the loss of link between the controller and all BDU modules at floors</p> <p>On BDUs Green LED fast blinking (0,5 sec): OK Green LED slow blinking (1 sec): OK BDU is not addressed Red LED ON: BDU defective Red LED slow blinking (1 sec): communication not established. Red +Green LED slow blinking (1 sec): sync.</p>	<p>Check: 1- BDU connector on screw terminals; 2- connection between the controller and the closest BDU; 3- the system configuration (§ 5.5)</p>
49	BDU fault		<p>In case of serial communication with floors, indicates the loss of link between the controller and one or more BDU at floors.</p> <p>On the BDU GREEN LED fast blinking (0,5 sec): OK GREEN LED slow blinking (1 sec): OK BDU not addressed RED LED ON: Faulty BDU RED LED slow blinking (1 sec): no communication. GREEN and RED LEDs slow blinking (1 sec): communication sync in progress.</p>	<p>Check BDU functions and its connections; Change defective BDUs; Repeat addressing procedure</p>
50	Drift control		<p>Drift control (if provided) activation: the system is put out of service at an extreme floor</p>	<p>Reset 82212 in the menu Faults (§ 5.3)</p>
51	Wrong Password		<p>If the system has a password, this fault appears after entering the wrong password for three times.</p>	

N.	Fault	Type	Description	Remedy
53	Fault UCM		<p>UCM Circuit Fault:</p> <p>Cod 2: Brakes open Cod 3: Brakes closed in travel</p> <p>Cod 6: error Test two valves</p> <p>Cod 8: error Test two valves (START ELEVATOR)</p> <p>Cod 100: UCM Detection</p> <p>Cod 200: Monitor error on RUCM1/RUCM2 Cod 201: RUCM1 Stucked Open Cod 202: RUCM2 Stucked Open Cod 203: RUCM3 Stucked Open Cod 204: Monitor OSG A3 (stud stucked in extended position) Cod 210: RUCM1 Stucked Close Cod 220: RUCM2 Stucked Close Cod 230: RUCM3 Stucked Close Cod 240: Monitor OSG A3 (stud stucked in retracted position)</p>	<p>Reset UCM in the menu Faults (§ 5.3).</p> <p>Cod 1: exclude maneuvers with open doors (re-leveling / early opening).</p> <p>Cod 12/13: check wiring and valve Y2 and its monitor signal</p> <p>Cod 14/15: check wiring and valve Y3 and its monitor signal</p> <p>Cod 100: means Unintended Cabine Movement (UCM) detection. If it happens togheter with Fault 41 (Fault ISO) check the sensors ZP1 and ZP2.</p>
54	Safety zone		<p>Only for lift with no car door and safety light curtains.</p> <p>Cod 0: Light curtain active during travel (lift wait for a new Car call to restart)</p> <p>Cod 1: Fail test CEDES door side A Cod 2: Fail test CEDES door side B Cod 10: Fail test on safety relay KSA Cod 20: Fail test on safety relay KSB</p>	<p>Check circuit according cod's info.</p>
56	Fault UAS		<p>Unintended Shaft Access Function enabled by "Shaft Monitor" parameter. Must be used BDU with additional door input (could be NO or NC). System detect a manually floor door opening monitoring the auxiliary door input.</p> <p>Cod 1: One Floor door manually open (with no open door command). Cod 2: More than one Floor door manually open (at different floors)</p>	<p>Reset UAS in the menu Faults (§ 5.3).</p>
57	Bypass door		<p>Only for EN 81-20. Bypass active on door safety contacts. (Moving enabled only in inspection) Check also SM1 module monitor</p> <p>Cod 1: Bypass Car active Cod 2: Bypass Pre-Locks active Cod 3: Bypass Locks active Cod 100: Module SM1 locked</p>	<p>Cod 100: Module SM1 is checked if only PME selector is active and no STOPS nor direction button pressed: in that condition module SM1 must be not enabled and SE3 input should be open.</p>

N.	Fault	Type	Description	Remedy
58	Overspeed		Only for Encoder positioning system. In inspection or Temporary mode Lift's speed is more than 0,63 m/s	Check encoder parameters or inspection speed in positioning menu.
59	Fault SHI		Only for 81-21 Pre-triggered device Cod 0: Wrong feedback when pre-triggered device is not energized Cod 255: Wrong feedback when pre-triggered device is energized Manual protection: Cod 101: Monitor Relay RMPP (contact doesn't open) Cod 102: Monitor Relay RMPP (contact doesn't close)	Check Pre-Triggered Device (or relay RMPP)



This symbol means a blocking fault: switch off main power and then switch it on again to put the lift back in service.

ANNEX II: Test and measures

The following tests and measures may facilitate controls and tests to be performed before putting the installation in service (EN81-X D) and during the periodic maintenance interventions (EN81-X E). Some measures can be performed only through the encoder counting system.

Tests can be performed only if the installation is in normal operation mode; select parameter "test" to perform the test and press ENTER to start it. The test procedure can be stopped by switching the installation to inspection mode.

Test 1: Measure of the stopping space and time in UP direction, DMG UCM module in acceleration out of the door zone

Before starting the test, move the empty car to the floor where you want to take the measure.

During the test, the car will move upwards until the end of that floor door zone; now the forced intervention of the UCM module is activated and the car will thus stop. After the car has stopped, the distance covered from the floor level is shown (to be compared to point 5.6.7.5 of EN81-20) and the stopping time since the UCM activation. Important: the stopping distance must be calculated before, considering the sum of intervention times (controller + stopping unit). After the test, the UCM module must be reset (menu <Faults> reset UCM).

Test 2: Measure of the stopping space and time in DOWN direction, DMG UCM module

Before starting the test, move the empty car to the floor where you want to take the measure.

During the test, the car will move downwards until the end of that floor door zone; now the forced intervention of the UCM module is activated and the car will thus stop. After the car has stopped, the distance covered from the floor level is shown (to be compared to point 5.6.7.5 of EN81-20) and the stopping time since the UCM activation. Important: the stopping distance must be calculated before, considering the sum of intervention times (controller + stopping unit). After the test, the UCM module must be reset (menu <Faults> reset UCM).

Test 3: Measure of the stopping space and time in UP direction at rated speed

Before starting the test, move the empty car to the ground floor.

During the test, the car will move upwards up to the second last floor (AGH for two stops installations); now the car stops. After the car has been stopped, the distance covered from the second last floor and the stopping level and the stopping time are shown.

Test 4: Measure of the stopping space and time in DOWN direction at rated speed

Before starting the test, move the full loaded car to the top floor.

During the test, the car will move downwards up to the first floor (AGB for two stops installations); now the car stops. After the car has been stopped, the distance covered from the first floor and the stopping level and the stopping time are shown.

Test 5: Re-leveling test with too high car (EN 81 point 14.2.1.2)

Before starting the test, move the car to the floor where you want to take the measure.

During the test, the car will move upwards until the re-leveling function is activated; now the car is re-leveled. After the car has stopped, the distance at which the re-leveling starts and the intervention time are shown. We recommend to perform the test at each floor to check the correct installation of the re-leveling sensors.

Test 6: Re-leveling test with too low car (EN 81 point 14.2.1.2)

Before starting the test, move the car to the floor where you want to take the measure.

During the test the car will move downwards until the re-leveling function is activated; now the car is re-leveled. After the car has stopped, the distance at which the re-leveling starts and the intervention time are shown. We recommend to perform the test at each floor to check the correct installation of the re-leveling sensors.

Test 7: Final limit switch test (EN 81 point 10.5)

Before starting the test, move the car to the ground or top floor.

During the test the car will move towards the shaft end until the safety chain opens (or until the FCO input is detected). After the car has stopped, the distance between the intervention floor and the limit switch intervention and the status of FCO input (NO contact for registering the limit switch intervention) are shown. The car can be moved beyond the limit switch through the inspection

control panel in the machine room (in inspection mode the movement beyond the top and bottom floor is disabled) to put the car or the counterweight on the shock absorbers and perform the rope slipping test. Move the car out of the limit switch area and put the installation in normal operation mode (if the second NO contact of the FCO input is connected, you must reset FCO in the menu <Faults>).

Test 8: Motor run time test (EN 81 point 12.10)

Before starting the test, move the car to the ground or top floor.

During the test the car will move towards the opposite extreme floor at null speed. After 5 seconds, the up/down run time error will be detected (check in the menu <Faults>). Clear all errors to put the installation in normal operation mode again.

Test 9: System balancing test

Before starting the test, place the cab on the ground floor with the weight suited to balance the system itself (typically 50% of the maximum load). During the test the cabin will start in the direction of the highest floor and the absorbed current at the middle of the shaft will be displayed. The cabin will then move to the lowest floor, once again displaying the absorbed current at the middle of the shaft. The values will also be preserved after the end of the test for evaluation purposes.

Test 10 ⇔ Test 17: Not Used

Test 18: Door Disable

Test for temporarily disabling door operators.

Test is useful if technician needs to make some test with lift in normal mode but without the risk some user can enter in the car.

It is possible to program a time of 1/5/10/30/60 minutes.

Time is valid also if Lift will be put in inspection / Normal again.

At the end of timer, lift comes back in normal mode.

Test 19: Black out Simulation

Only for installation with full emergency option. Lift behaviour is the same you have when power supply goes off, so it make an automatic emergency moving the car to the floor and opens the door.

Test 20: Telephon call for low batteries level simulation

Controller send command to JTOC (output ALARM Enable) as if the battery level was wrong for an emergency call. This signal has to be connected to the telephone's input for emergency call.

Test 21: Not Used

Test 22: Not Used

Test 23 ⇔ Test 26: Not Used

ANNEX III: Instructions for Software update

PlayPad (PLP) SW update procedure

SW update file for PLP depends on which Playpad is installed:

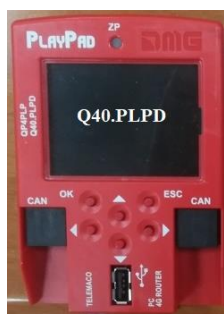

PLAYPAD: FileName.PP2



PLAYPAD WiFi: FileName.PP4

Insert the USB device into the slot, waiting for the message as in the Figure 1.

Select "Put a file into PlayPad" (default), press OK button. Window changes into Figure 2.

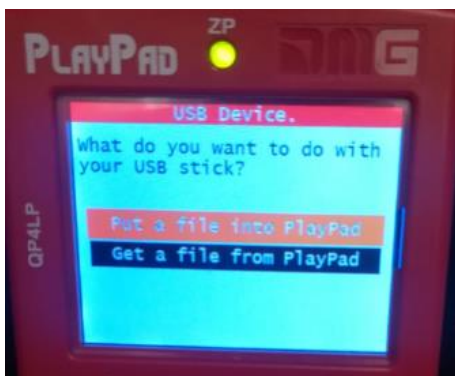

Figure 1



Figure 2

Follow the instruction on screen and select the .PP2 file (in the example PLP2_2.PP2) and press OK. Window changes into Figure 3.

Press OK to confirm the update process. Window changes into Figure 4.



Figure 3

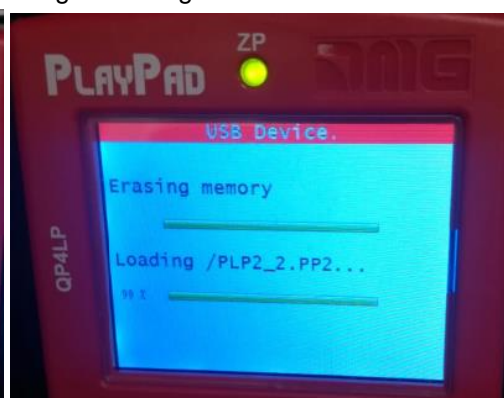

Figure 4

At the end of Procedure you have to remove the USB (Figure 5 or Figure 6 will be appear)



Figure 5

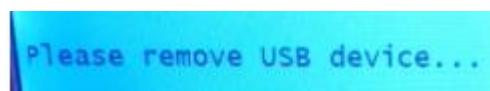

Figure 6

Devices SW update procedure

Insert the USB device into the slot, waiting for the message as in the Figure 7 and Select “Put a file into PlayPad” (default) and press OK button. Window changes into Figure 8.

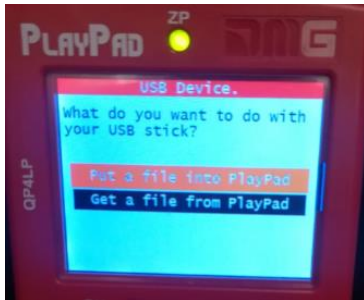

Figure 7



Figure 8

Follow the instruction on screen and select the *.bin file and press OK. Window changes into Figure 9. Press OK to confirm the update process. Window changes into Figure 10, wait for a while.



Figure 9



Figure 10

Select the Device (or device group) to update and press OK (Figure 11). Window changes into Figure 12: wait until the process is completed. If you need to press any arrow button to switch on the backlight.



Figure 11



Figure 12

When the process ends (Figure 13) press Esc button until the window-shows “Please remove USB Device” (Figure 14).



Figure 13



Figure 14

Device	Time needed for updating SW
Mother board (Playboard Controller)	3 minutes
PlayPad 4.0	1 minute
TOC Board (Car TOP Interface)	1 minute
JTOC Board (Car COP Interface)	1 minute
Serial Pushbittons Intarfaces (BDU Devices)	30 seconds
Expansion boards (PIT8 / 16RL / 16IO)	30 seconds

Table III.1 – Timing for SW update

ANNEX VI: Emergency/Rescue Manoeuvres

Rescue operation for hydraulic lifts



The operation must be performed by qualified personnel.

1. Open the Main Switch MDP;
2. See the status of the ZP signal. If is on (i.e. the car is already at the floor), go to step 5. If is off, go to step 3;
3. Press and hold the button on the hydraulic unit to lower the car. Use the hand pump lever to move the car up;
4. Continue to move the car until it reaches a floor. The ZP light will be illuminated;
5. Unlock the car doors;
6. Close the doors and call the Maintenance Service.

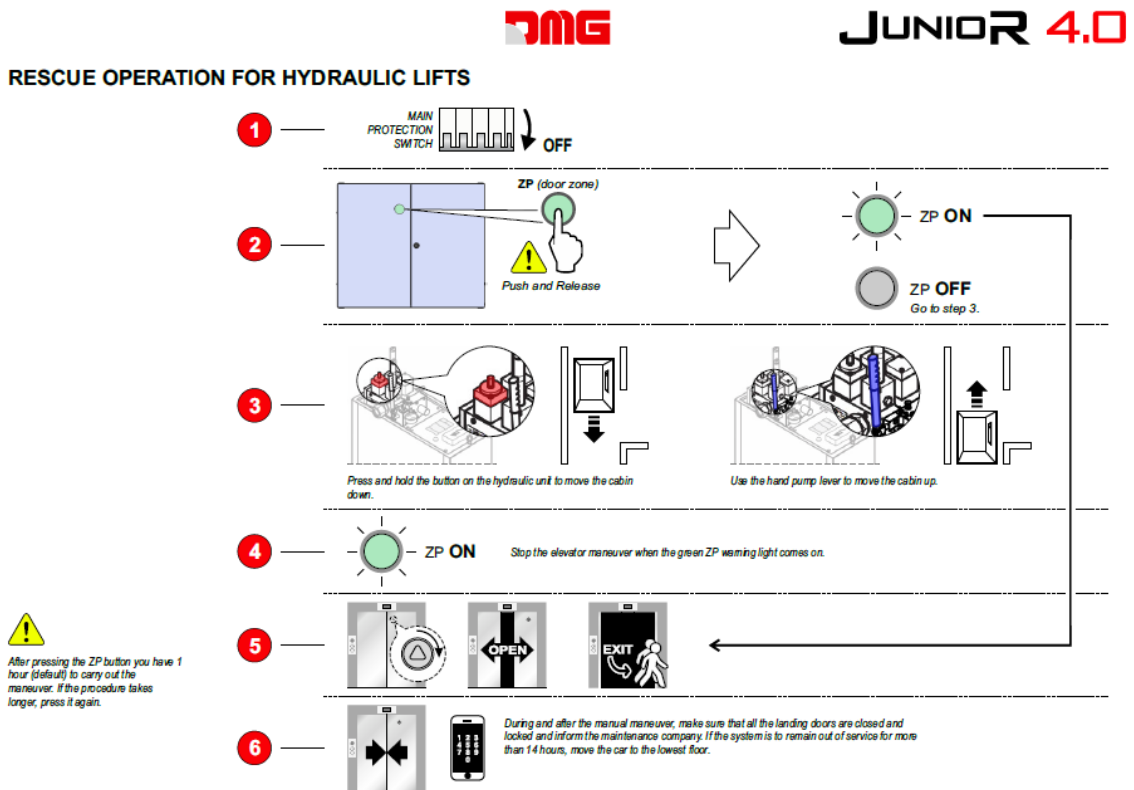

ANNEX VIII: UCM Circuit

The following table shows how to set the UCM Monitor parameter according to the device or circuit for detecting uncontrolled movements.

For Hydraulic installations the parameter is used for:

-) Central unit / valves configuration (see table VIII.2)
-) UCM solution managed by controller

Monitor UCM		Device / Hydraulic Control Unit	UCM Solution	Actuator
Tipo	Tempo			
No		Not present	No	-
1	1,5 s	Overspeed Governor OSG A3 Montanari RQ-AXXX	Yes	Safety Gear
2	1,5 s	Controller = Brake monitor	Yes	A3 Certified Brakes
3 ⇔ 29		Do not use		
30	1,5	Hydro Central Unit with Electromechanical valves (A3 second down valve is optional, no test performed)	Without UCM / ELGO	-
31 ⇔ 79		Do not use		

Table VIII.1 – Monitor UCM

Control Unit	A3 valve	Valves command	Monitor UCM	Note
Generic 2 or 3 valves	No	CV1 = UP CV2 = DOWN CV3 = HIGH SPEED	30	CV4 can be used instead of CV1 as UP valve in order to exclude Soft Stop (valve energized also after motor stops)

Table VIII.2 – Hydraulic Central unit managed

(*) = No test 2 valves – (**) = with 2 valves test

ANNEX IX: Installation Type

The following table indicates how to set the UCM parameter according to the type of system, including the solutions adopted for protection in systems with reduced headroom and / or pit spaces.

The use of monostable contacts involves the presence of a bistable circuit in the switchboard.

UCM		Installation type	Reduced		Door contacts	
Type	Time		PIT	HEAD	Monostable	Bistable
No		EN 81.1 / EN 81.2				
1 ⇔ 58		Reserved – Do not use				

Table IX.1 – UCM

ANNEX XI: Fire operation programming procedure

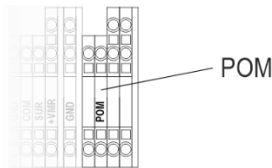
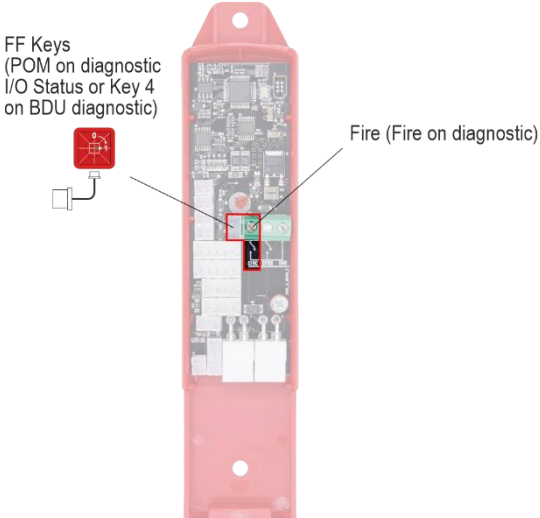
Wirings	
<p>Input POM Input located on the screw terminal</p>	
<p>Input Fire and input FF keys Input located on BDU</p>	

Evacuation according to EN 81-73

- a. **SITUATION 1: ONLY ONE EXTERNAL FIRE CONTACT FOR FIRE DETECTION (EVACUATION)**

Enter the menu "SPECIAL FUNCTIONS" submenu "FIREFIGHTERS" and set:

- The floor where the elevator must go in case of direct activation of the contact from the external fire contact
- The Access (if there are multiple doors)
- The stand-by state of the contact of the external fire contact (NO or NC).
- Program contacts NO type for the input FIREMAN
- The operation EN 81-72 (b)

Connect the contact to the POM input of the controller.

Using these settings and once the contact is activated by the external fire contact, the elevator will go to the programmed floor, open the doors and remain stopped (PHASE 1). The Landing Operation Panels and the Car operating Panel are disabled. The reactivation of the elevator will take place at the deactivation of the contact from the external fire contact.

b. **SITUATION 2:** EXTERNAL FIRE CONTACT AND LIFT WITH ALTERNATIVE EVACUATION FLOORS

Enter the menu "SPECIAL FUNCTIONS" submenu "FIREFIGHTERS" and set:

The first evacuation floor

- The Access (if there are multiple doors)
- The stand-by state of the key switches (keys are optional) (use NO)
- The operation EN 81-73
- Additional evacuation floors (up to three different) in priority order
- Connect the wiring as indicated in the electric diagram: the contacts of sensor must be connected to the BDU's input FIRE-GND. (In case of LOP's parallel wiring must be used an 16IO expansion board in the controller). In case of floors not managed by the control unit, the corresponding inputs must be shunted (if the fire sensors are programmed with NC contact) .

The activation of one of signals:

- POM Key (optional contact)
- FIRE (of any of the BDUs)

will start PHASE1 of the operation (also called evacuation) and will not allow car calls without the activation of the fire-fighters key-switch in the car. The evacuation floor could be different according the rule:

- If FIRE of main floor is not active => evacuation to main floor
- Else, If FIRE of main floor is active => evacuation to alternative floor (the first with FIRE not active)

In case of multiple FIRE inputs active on all of alternative floors, it will be used the main evacuation floor. During the evacuation to a floor (when car is moving), if the corresponding input has the FIRE active, destination floor will be changed according the same rules.

Lift stops at evacuation floors, with door open (could be possible to set closed parking). Lift comes back in normal mode when the external signals (FIRE and optional POM/FIREMAN) comes back in the inactive status.

Annex XII: Timing Diagrams

Hydraulic Lifts – Motor contactors

Direct

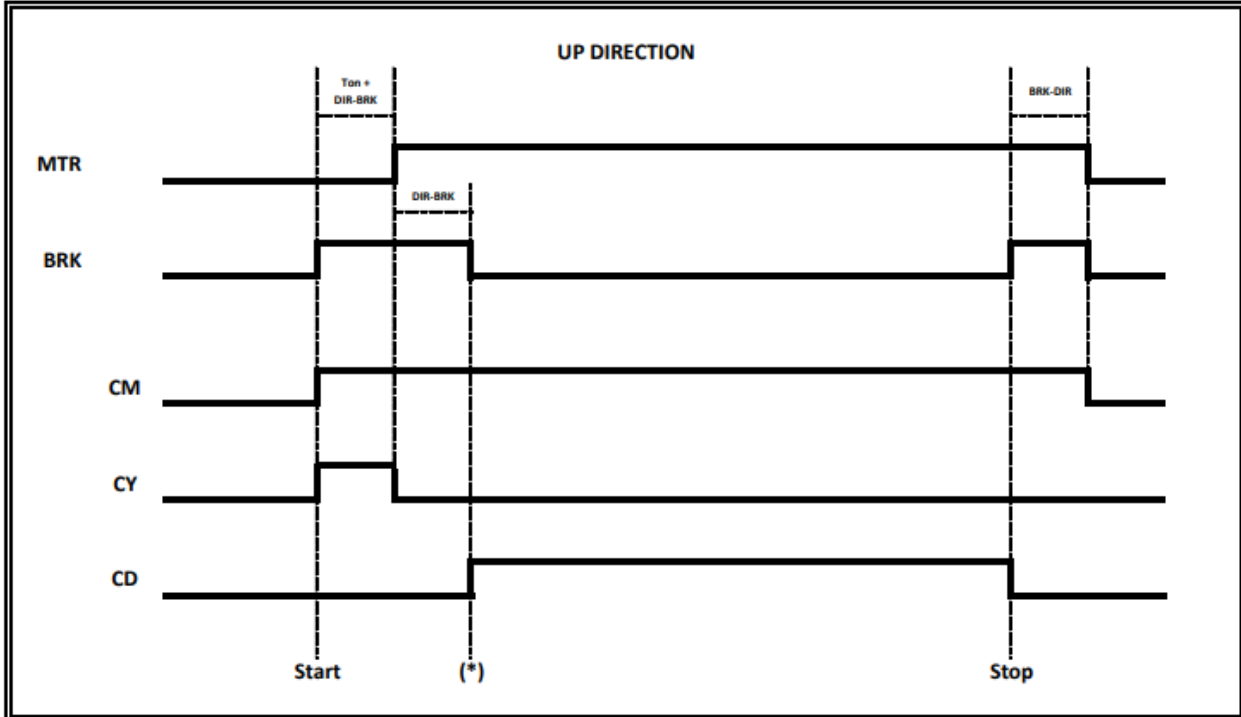

(T on) = Contactor's Time Activation, check on cco feedbacks
 (*) Signal feedback for start Valve UP command

Hydraulic Lift – Valves Contactors / Valve commands

Monitor UCM = 30

(2 Valves / 3 Valves)

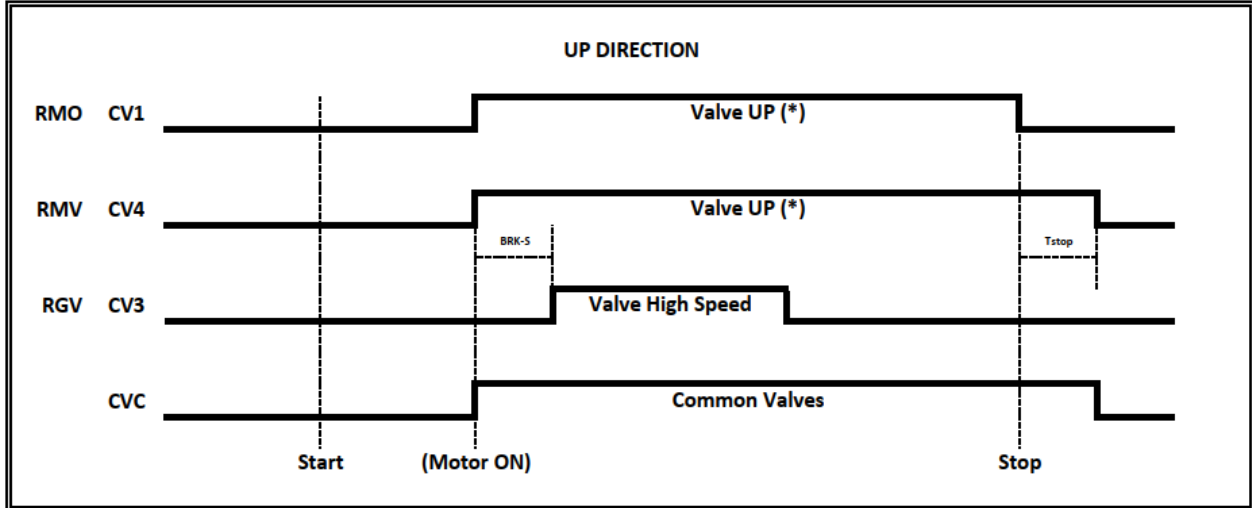

(*) In case of Soft Stop use CV1 for UP Valve's CONTACTOR
 (*) In case of no Soft Stop use CV4 for UP Valve's CONTACTOR - Tstop = BRK-DIR + 1,5 s

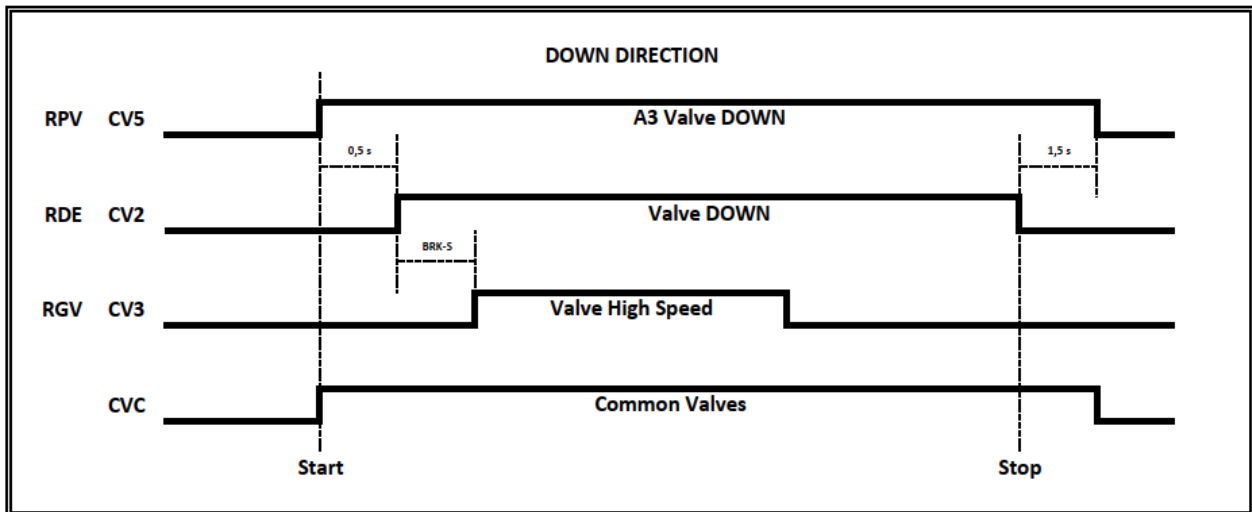

3 Valve => NO Double Valve DOWN test (A3 Valve Down couldn't be present)
 3 Valves + A3 => Double Valve DOWN test

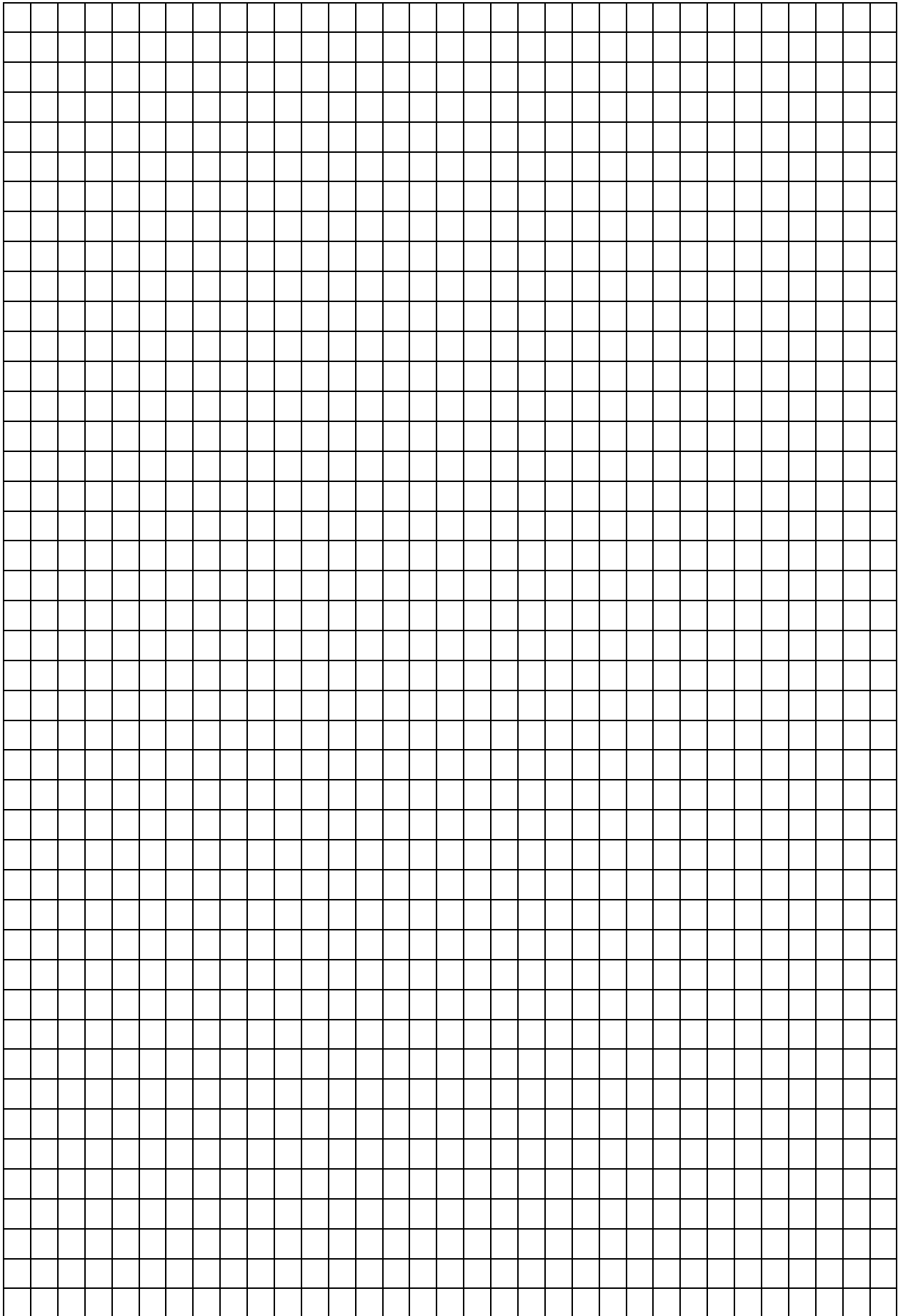

JUNIOR 4.0



DMG SpA • Via delle Monachele, 84/C • 00071 POMEZIA (ROMA) - ITALIA
Tel. +39 06930251 • www.dmg.it