



**DMG**

**JUNIOR 4.0**  
**HYDRO**

**Quick installation guide**

*English*

V 1.2

## INDEX

<b>PHASE 0</b>	<b>INSTALLATION OF BASE ELEMENTS</b> .....	<b>pg. 6</b>
	INSTALLING THE CONTROLLER .....	pg. 6
	CONNECTING THE MAIN POWER SUPPLY .....	pg. 7
	CONNECTING MOTOR OUTPUTS .....	pg. 9
	FIXING THE TRAVELLING CABLE .....	pg. 10
	CONNECTING THE TRAVELLING CABLE TO THE CAR BOARD .....	pg. 10
<b>PHASE 1</b>	<b>TEMPORARY MODE &amp; ELECTRICAL CONNECTIONS</b> .....	<b>pg. 11</b>
	TEMPORARY OPERATIONS .....	pg. 11
	INSTALLING THE SAFETY CHAIN .....	pg. 13
	CONNECTING CAR DOORS OPERATOR .....	pg. 15
	CONNECTING LIGHT BARRIERS .....	pg. 17
	CAR POSITION READING SYSTEM .....	pg. 18
	CONNECTING THE CAR ILLUMINATION .....	pg. 20
	CONNECTING THE INSPECTION BOX .....	pg. 22
	INSTALLING THE CAR PANEL .....	pg. 23
	INSTALLING THE FLOOR PANELS .....	pg. 24
	INSTALLING THE EMERGENCY PHONE .....	pg. 25
<b>PHASE 2</b>	<b>NORMAL MODE &amp; SYSTEM ADJUSTMENTS</b> .....	<b>pg. 26</b>
	SWITCH TO NORMAL SERVICE MODE .....	pg. 26
	ADJUSTING FLOOR STOPPING ACCURACY .....	pg. 27
	CONNECTIVITY (FUSION APP) .....	pg. 28
	TESTS .....	pg. 30
	BASIC TROUBLESHOOTING .....	pg. 31
	RESCUE OPERATION FOR HYDRAULIC LIFTS .....	pg. 32
	ADVANCED SETTINGS .....	pg. 33

## JUNIOR 4.0 - ELECTRIC SYSTEM FOR HOMELIFTS

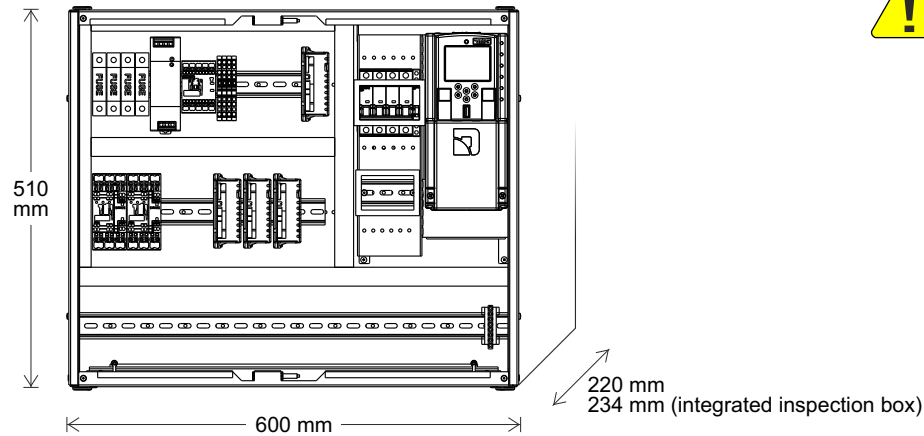

**(M)** 230 V ( $\leq 32A$ ) / 400 V ( $\leq 16A$ )

600x510x220 mm

~ 25 kg

✓ Single Phase / Three Phase

✓ 7 stops maximum

**EN**  
**81-41**



### SAFETY NOTES

#### Installation

The control panel must be installed internally with a degree of pollution of not more than 2.

The cabinet has an IP2X degree of protection.

The controller setup and maintenance has to be made by qualified technicians after having carefully read the documentations and electrical schemes provided with the controller.

Protection toward indirect contacts has to be realized through magnetothermic and differential switches and a grounding system. Unless otherwise specified, the customer is requested to provide these protections.

Please refer to the wiring diagram supplied with the control panel for the following protection circuits:

- magnetothermic protection of the motor circuit
- magnetothermic protection of the safety circuit
- protection fuses of all other circuits

Protection measures against electric shock:

- The control panel case of the is metallic and must be grounded as indicated in the circuit diagram supplied with the control panel.
- The command and control circuits (24V) are galvanically separated from the main power supply as indicated in the wiring diagram supplied with the control panel.

#### Maintenance

For control panel's maintenance, please refer to the manual supplied with the control panel. During periodic inspections of the system, check the alarm circuits' battery status of the and the floor return circuit (if present) .

Refer to the packaging instructions to handle and move the control panel.

### 7-SEC SAFETY MODULE

#### Description

SECU.24 module is an electronic device installed in DMG lift control panel that allows to check the status of 7 point of the safety chain of the lift.

The main function of this module is to guarantee galvanic isolation between the safety circuit and the electronic circuits of the control panel.

There is only one version of this module available:

- SECU.24 for control panel with safety circuit powered at 24 VDC [-15 / + 10%]

#### Installation

The SECU.24 module is supplied by DMG already installed and connected in the control panel. No intervention by the installer is required during commissioning of the control panel.

The common of the connections to the electric safety chain is traced on the printed circuit board in such way, that the common to the contactors or relay-contactors will switch off at interruption of the common (CBC(1) / CBC(9)).

#### Working conditions

The SECU.24 module is installed in a metal earthed cabinet with minimum IP20 protection and fixed on a DIN rail at following service condition:

- Indoor Use.
- Temperature: -5°C / +40°C
- Relative Humidity: must not exceed 50% at a max temperature of +40°C; may increase at lower temperatures, for example, can be 90% at 20°C.

#### Maintenance

In the event of a fault, the device must be replaced, it must not be opened or repaired.

## SYSTEM LAYOUT

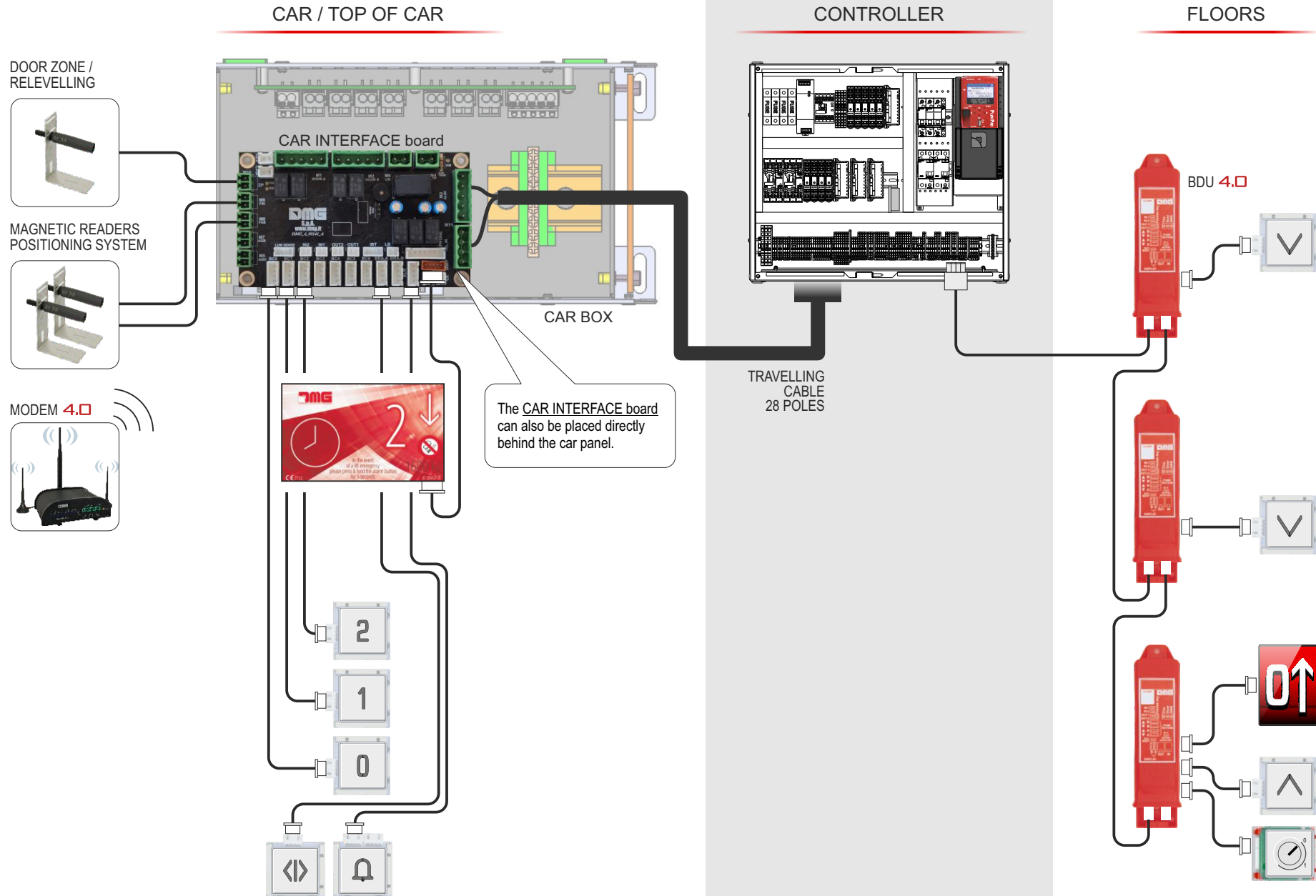



## SYSTEM COMPONENTS

### TOP OF CAR

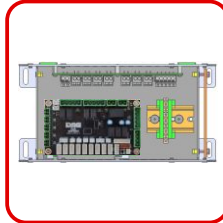
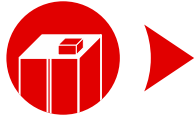

||||| QJ4.CTBOXS  
CAR box



||||| QJ4.C28CS  
Travelling cable kit (x m)

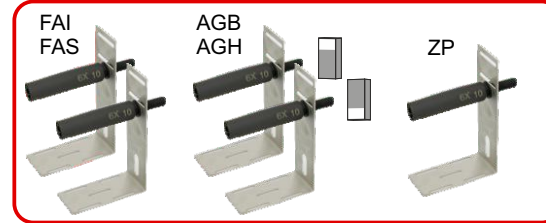

||||| QJ4.CTKIMP.H5 / QJ4.CTKIMP.H4 (without AGH)  
Magnetic readers positioning system + door zone/relevelling  
+ top/bottom reset proximity switches and reset magnets

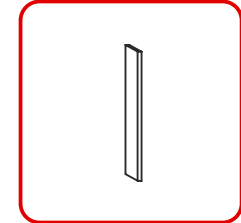

||||| QJ4.SHCAL  
1 magnet

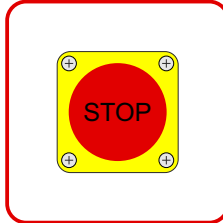

||||| QJ4.CTPS  
Top of cabin stop

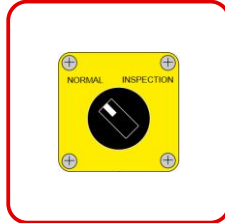

||||| QJ4.CTPM  
Inspection box



||||| QJ4.CTPSTISP  
Inspection box + Stop

### CAR

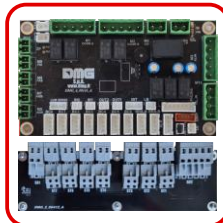
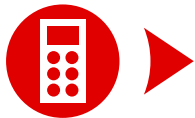

||||| QJ0.CTSTI  
Car INTERFACE board  
+ 7-SEC board

### SHAFT

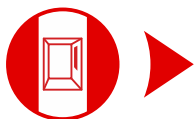

||||| QJ4.SHEX1/2  
Final limit switch kit



||||| QJ4.SHP / QJ4.SHC  
Safety chain (doors / pit)



||||| QJ4.SHPSH  
Pit stop



||||| C40.BDU  
Floor interface (BDU)



||||| QJ4.SKLED\_F10 / F20  
+ QJ4.SKLED\_V  
Shaft illumination kit (10 / 20 m)

## PHASE 0 - INSTALLATION OF BASE ELEMENTS

### INSTALLING THE CONTROLLER

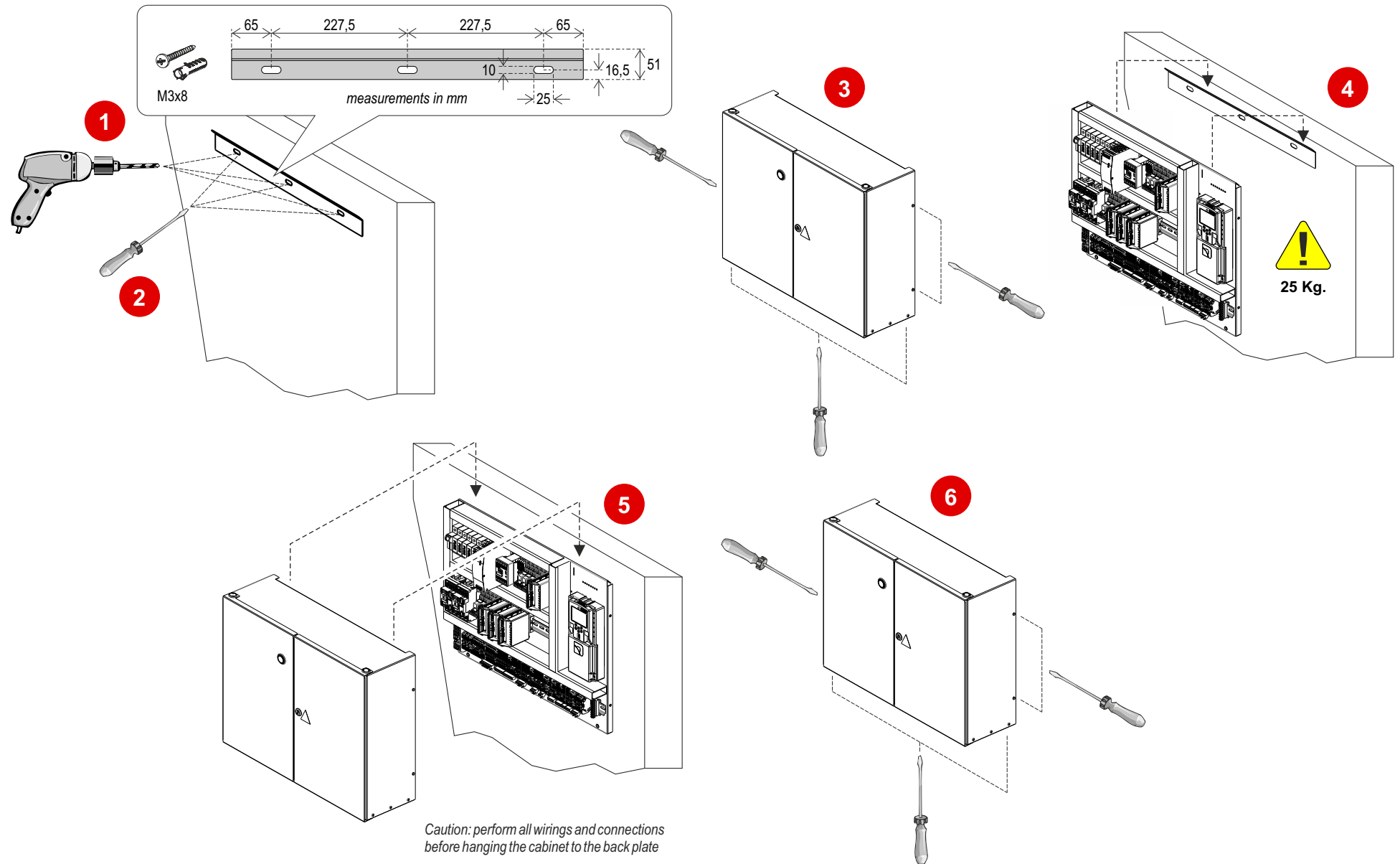

# CONNECTING THE MAIN POWER SUPPLY

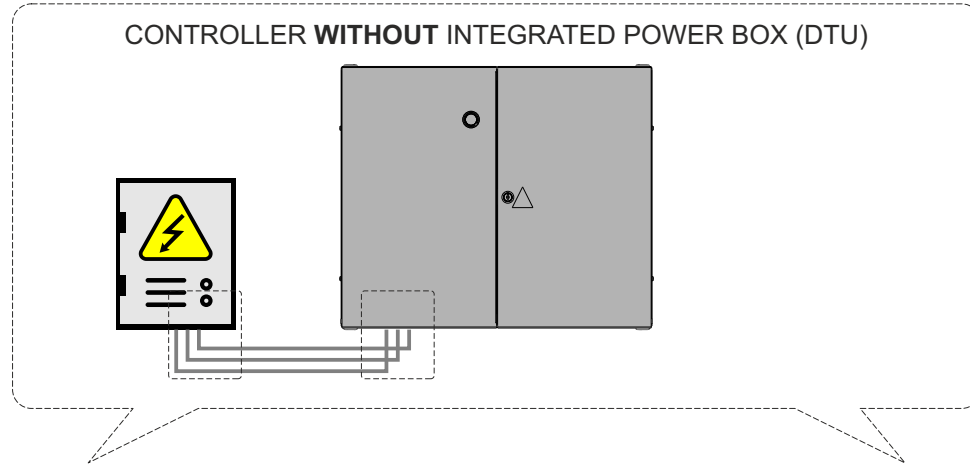

SINGLE-PHASE

THREE-PHASE

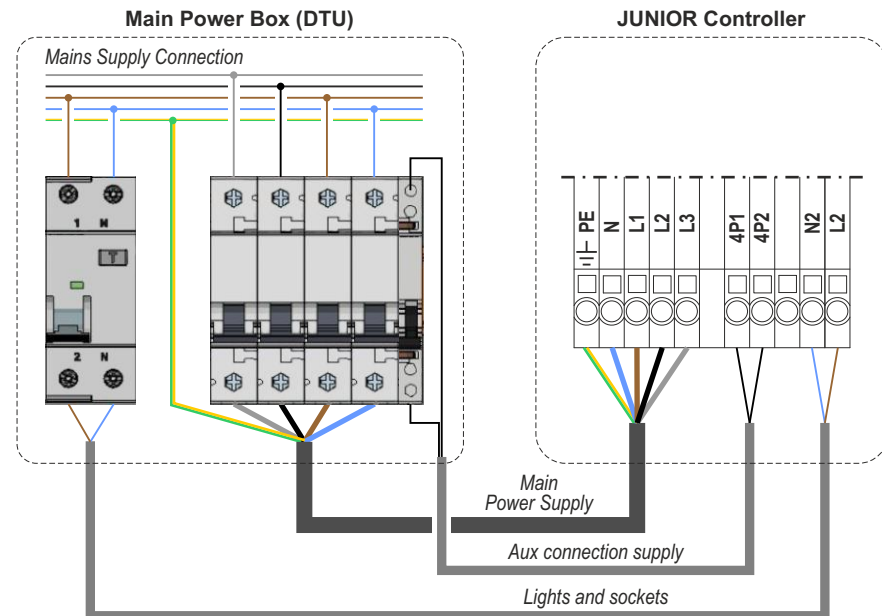
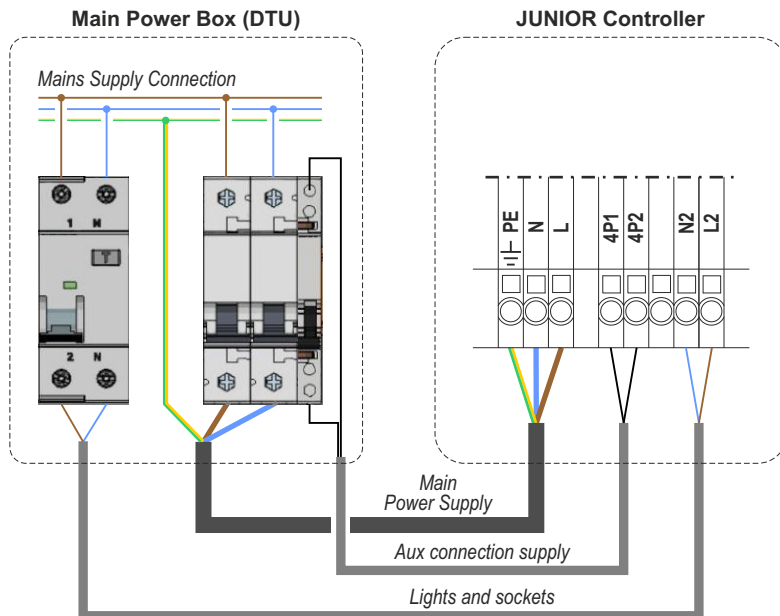

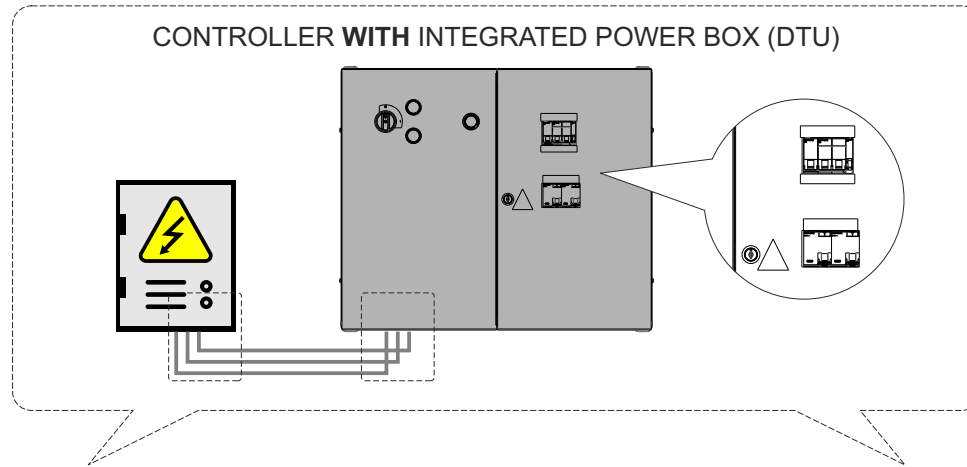

SINGLE-PHASE

THREE-PHASE

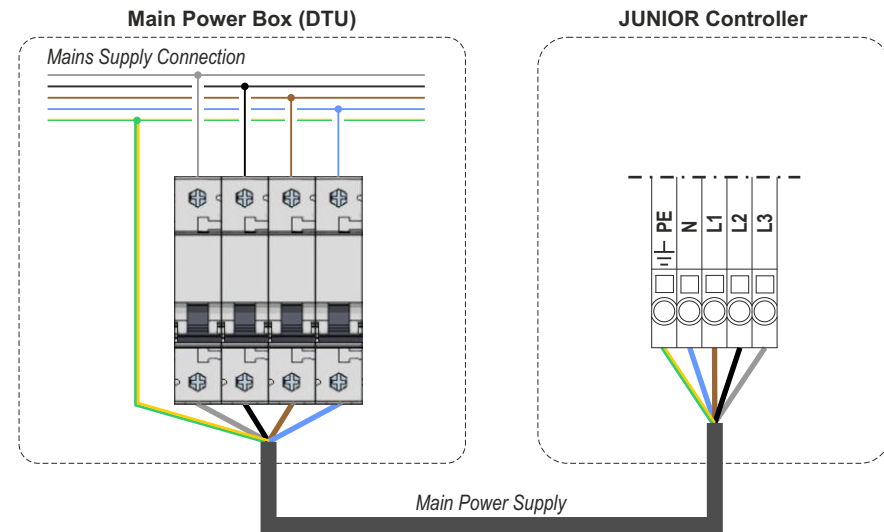
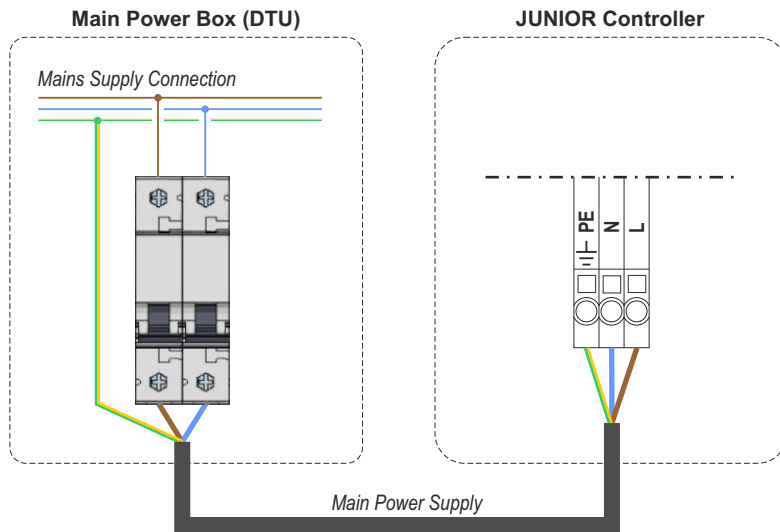

# CONNECTING MOTOR OUTPUTS

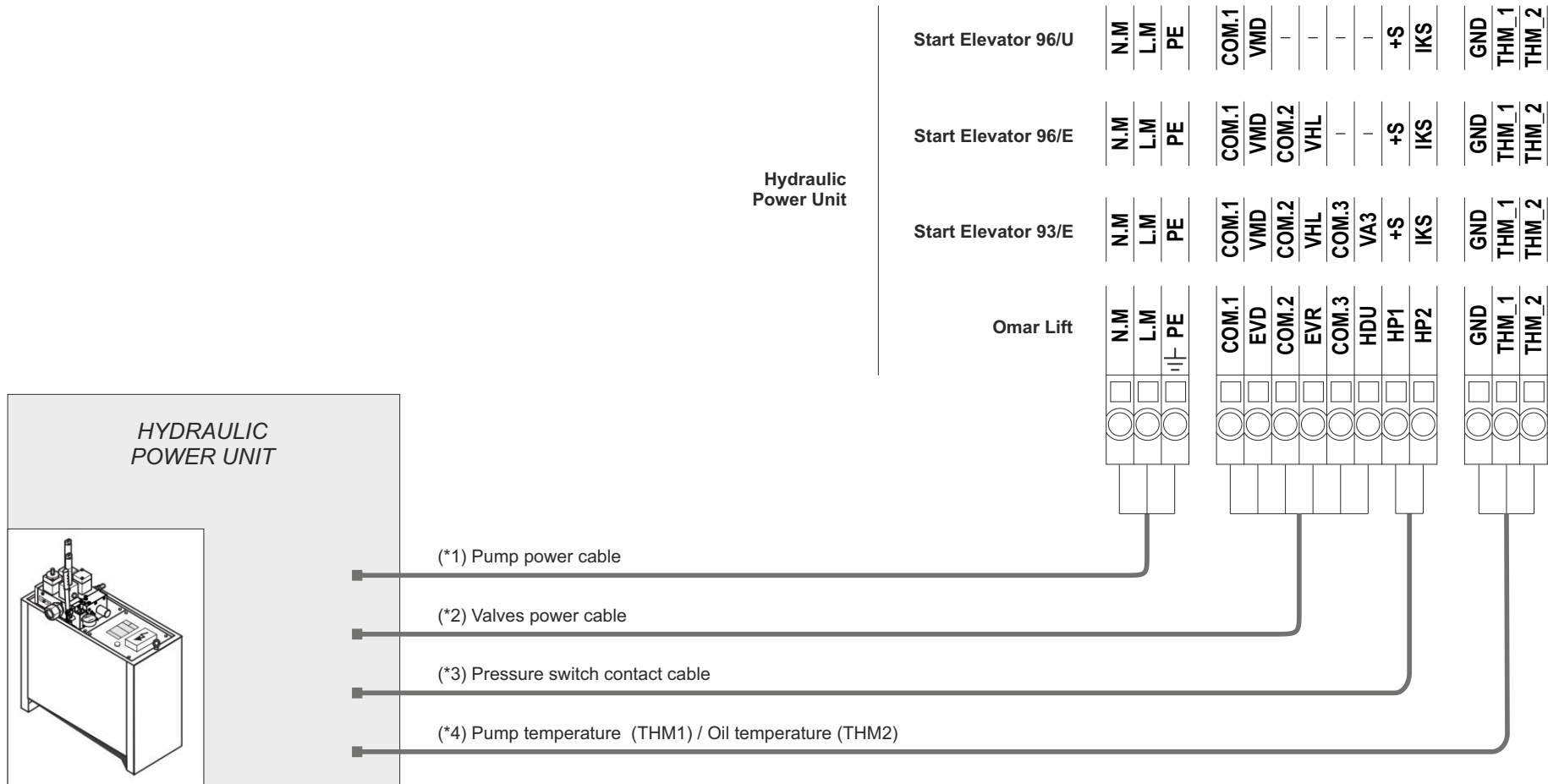

(\*1) QJ4.SMCMH16.M Up to 15 A  
 QJ4.SMCMH32.M Up to 31 A

(\*2) QJ4.SMCCV1 1 valve  
 QJ4.SMCCV2 2 valves  
 QJ4.SMCCV3 3 valves

(\*3) QJ4.SMCHPS

(\*4) QJ4.SMCTHMS Single thermal  
 QJ4.SMCTHMD Double thermal

## FIXING THE TRAVELLING CABLE

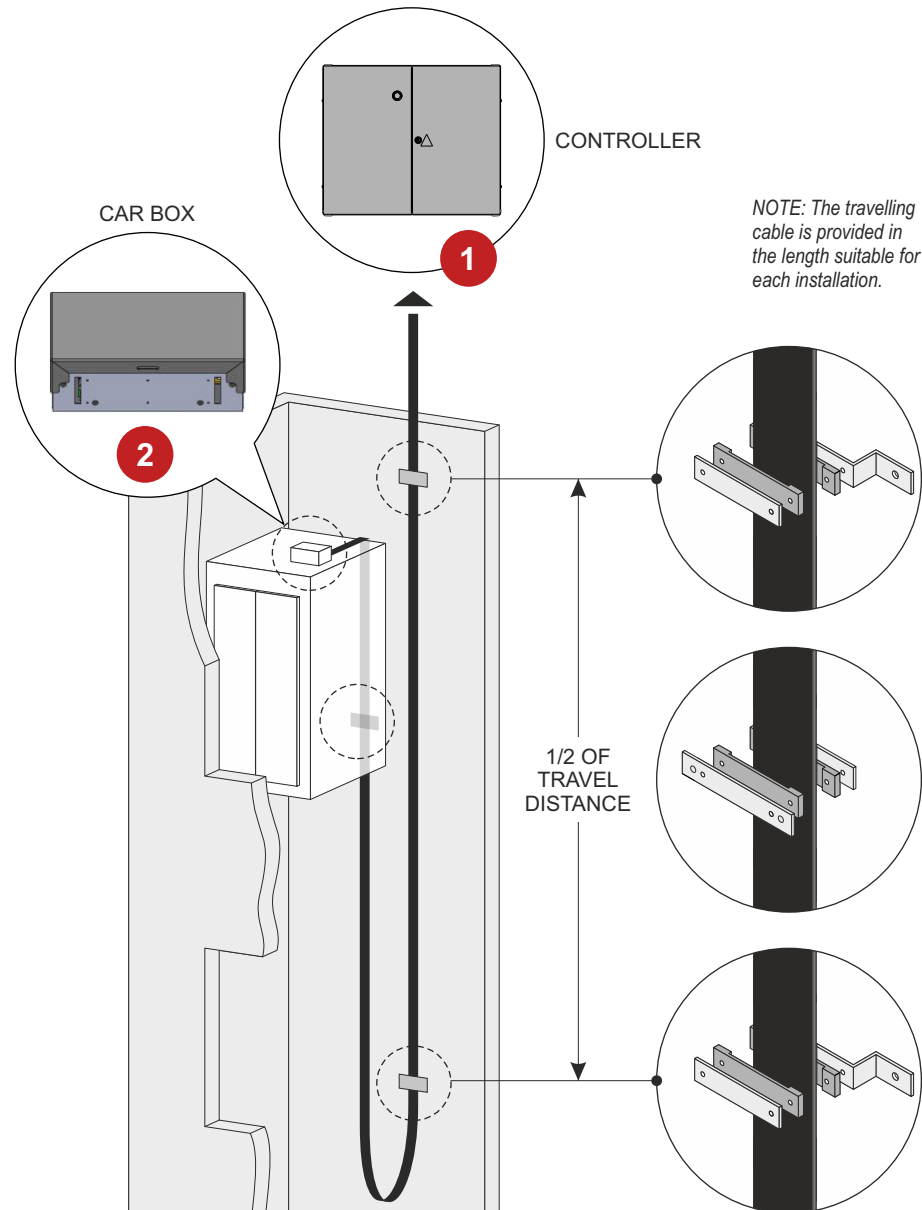

## CONNECTING THE TRAVELLING CABLE TO THE CAR BOARD

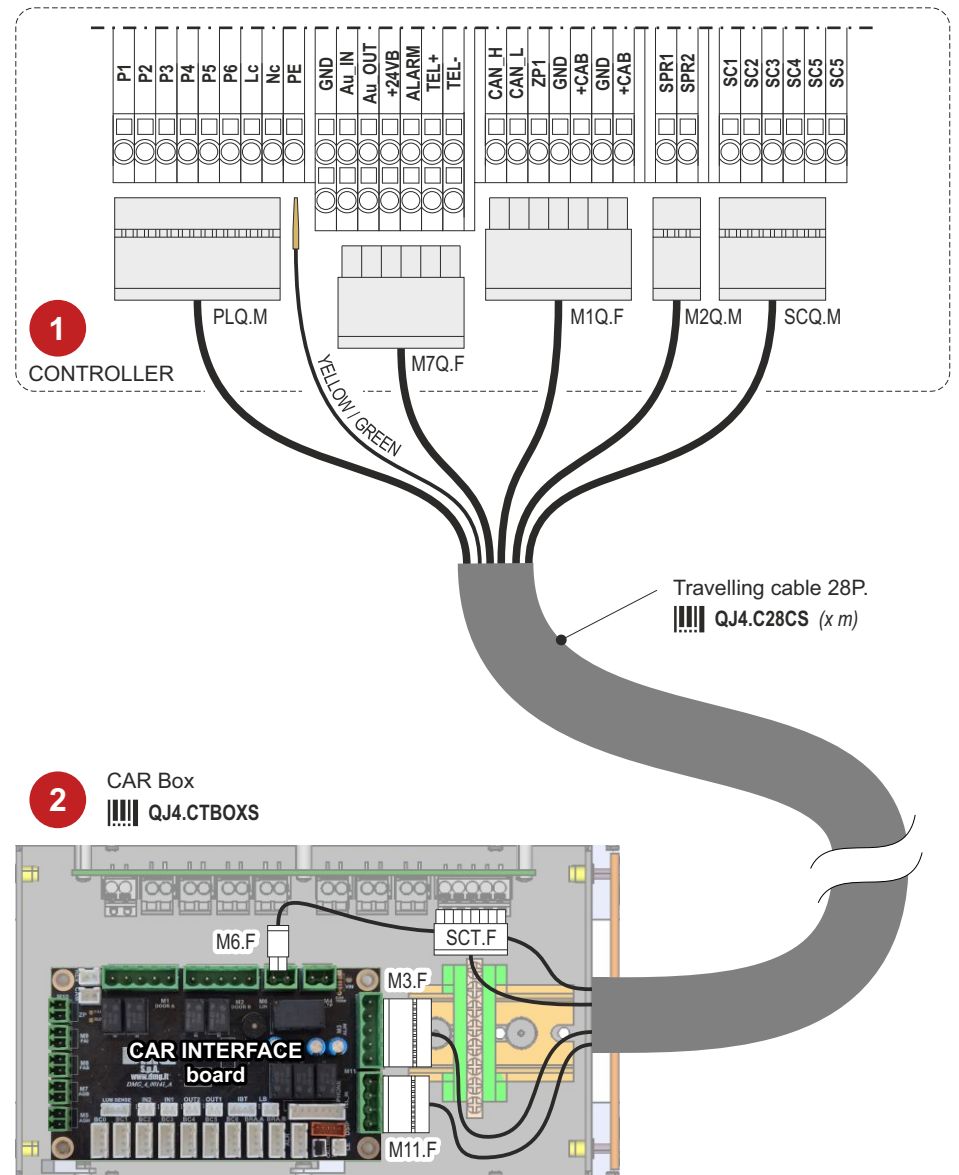



## PHASE 1 - TEMPORARY MODE & ELECTRICAL CONNECTIONS

### TEMPORARY OPERATIONS

CONTROLLER **WITHOUT** INTEGRATED INSPECTION BOX (PME)

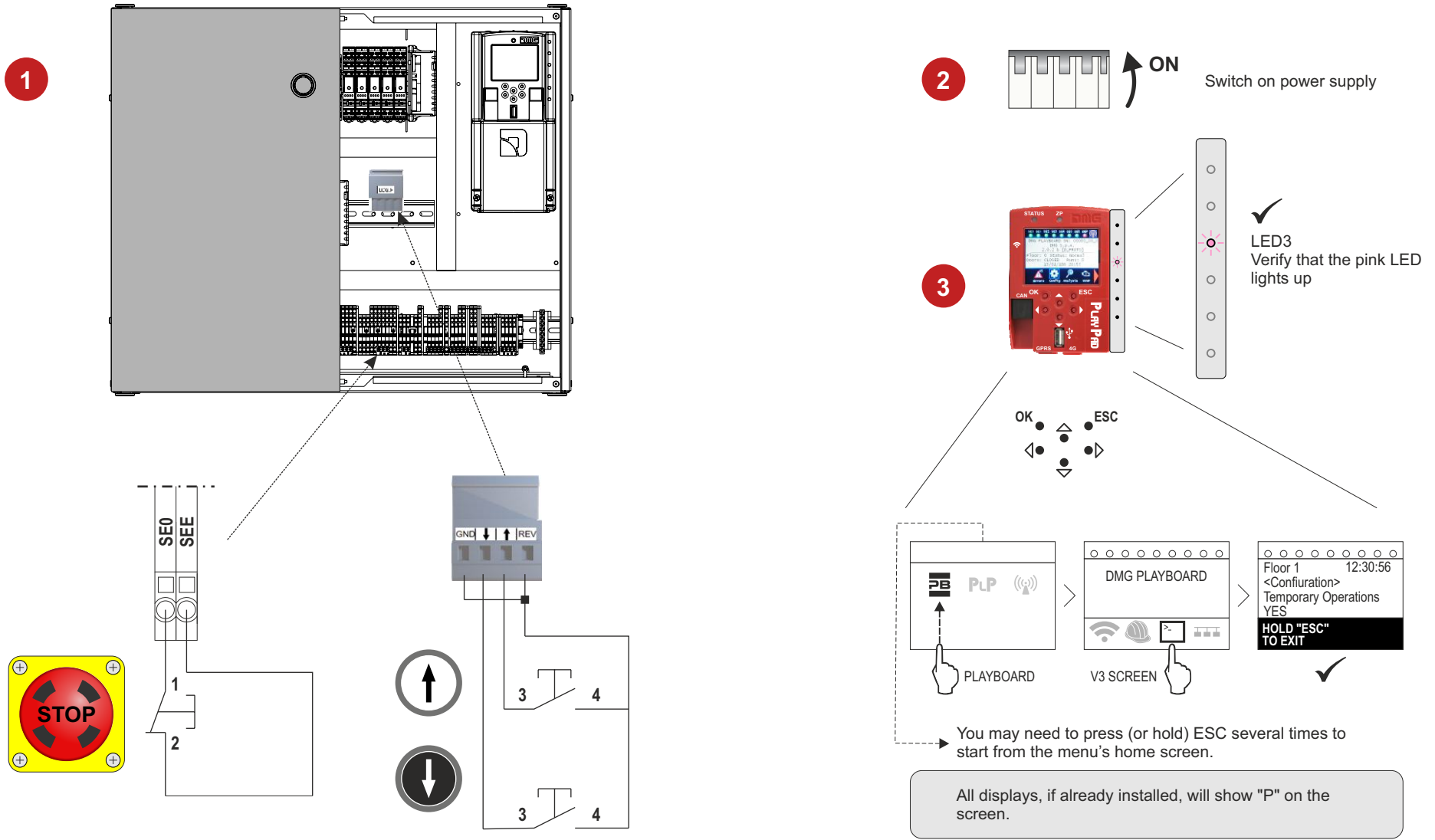

CONTROLLER WITH INTEGRATED INSPECTION BOX (PME)

1

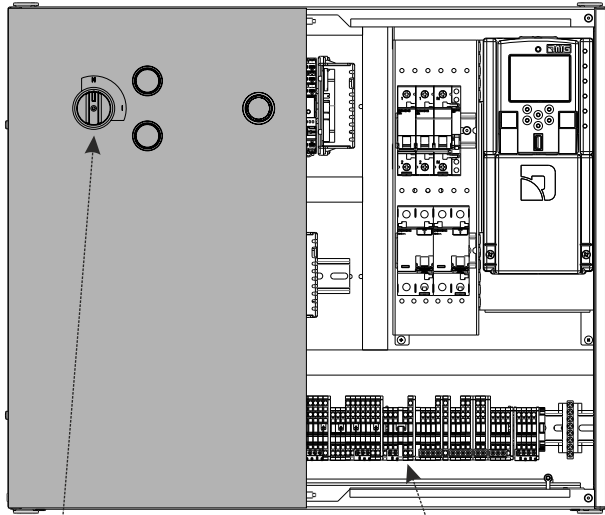

INSPECTION



NOTE: The inspection mode activated from the controller does not enable the car movement via car buttons.

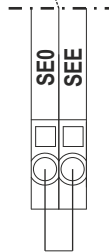

2



Switch on power supply

3

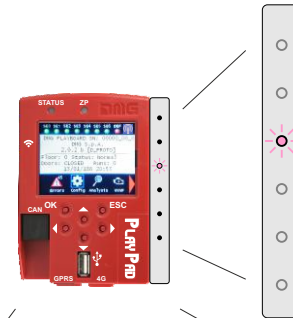

LED3  
Verify that the pink LED lights up

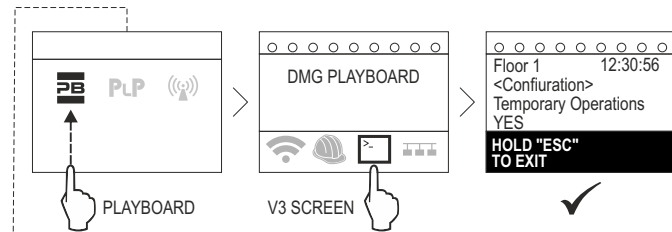
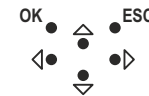

You may need to press (or hold) ESC several times to start from the menu's home screen.

All displays, if already installed, will show "P" on the screen.

## CONNECTING THE SAFETY CHAIN

IN THE CAR

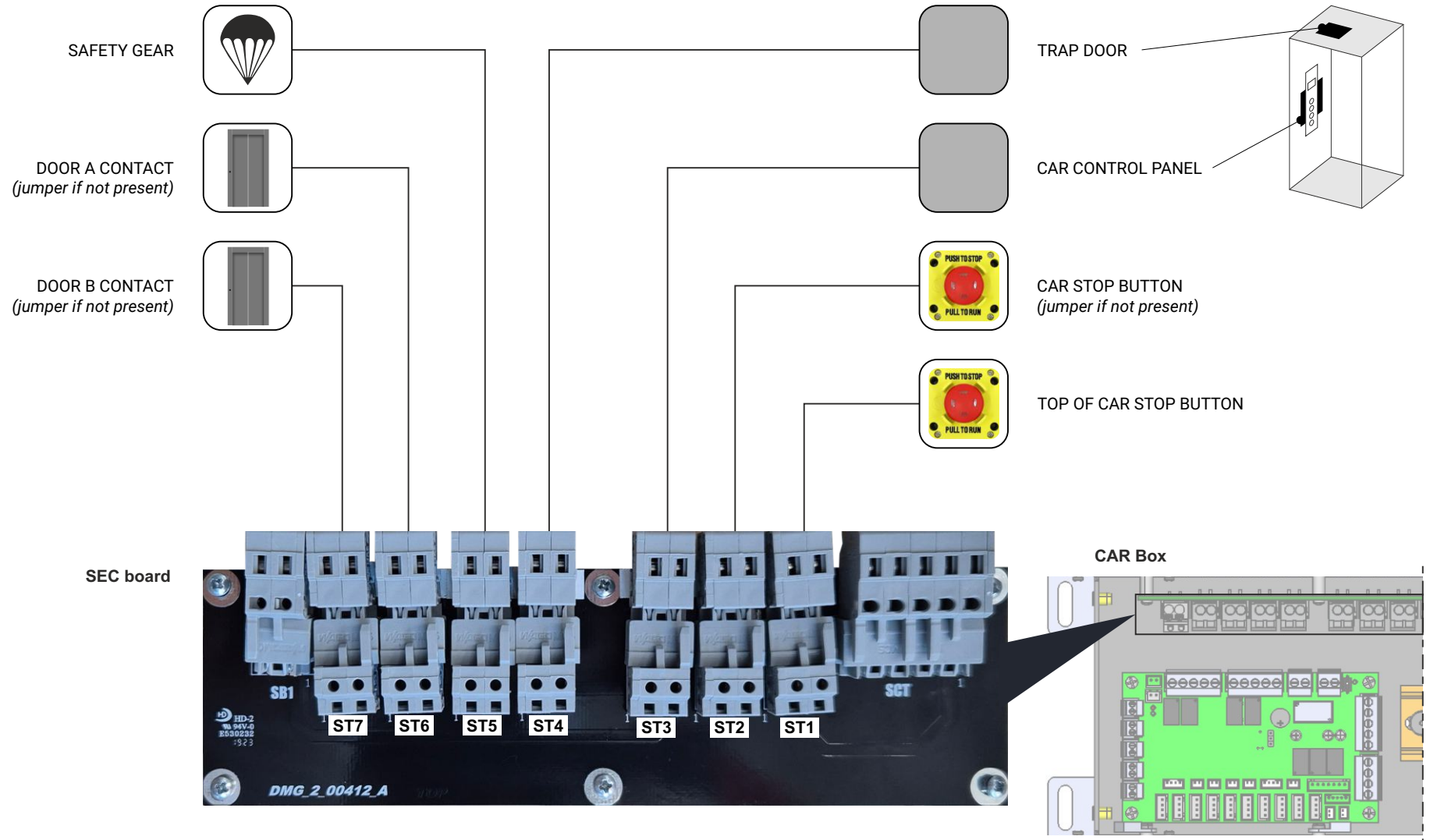

## CONNECTING THE SAFETY CHAIN

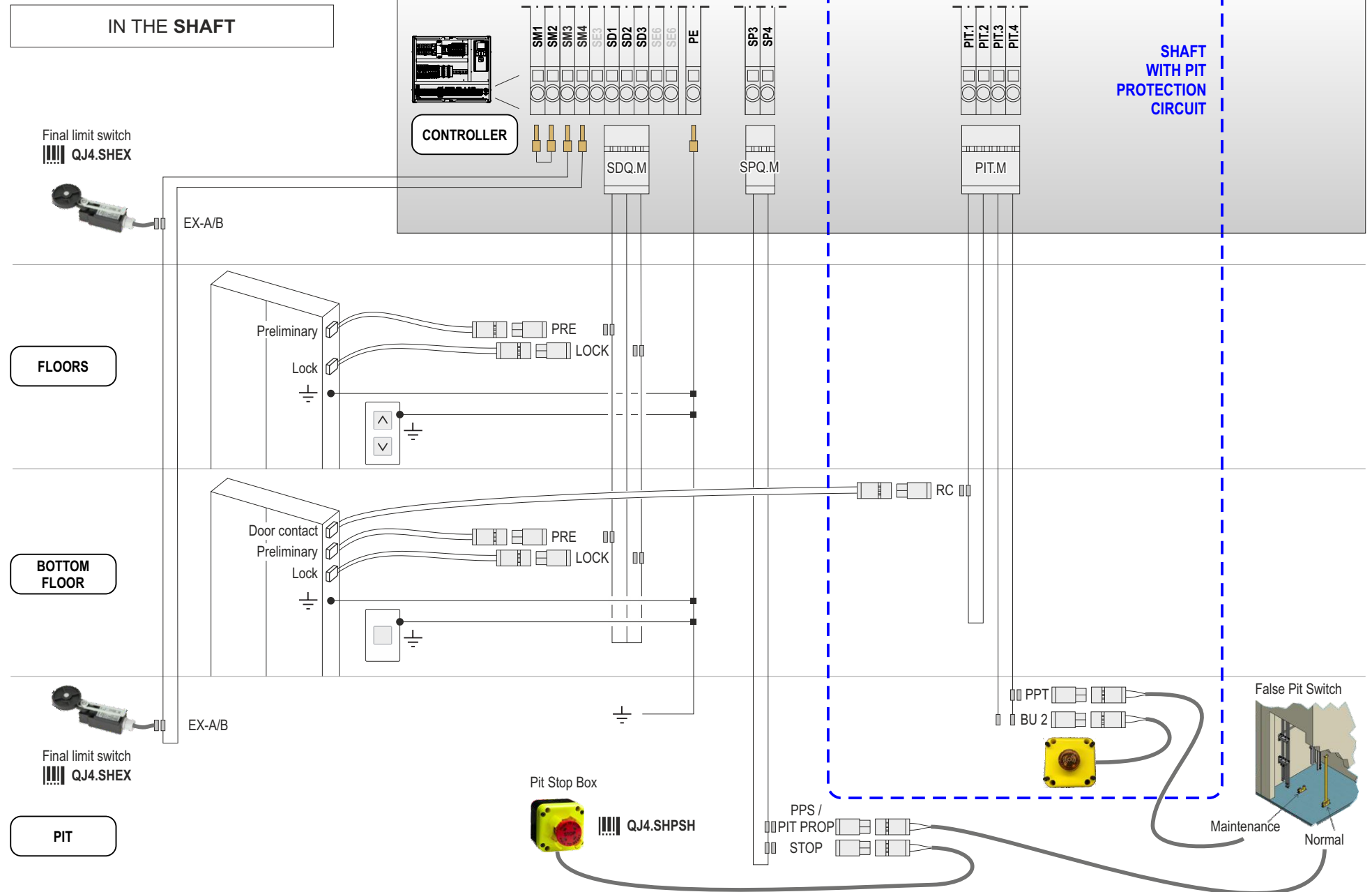

## CONNECTING CAR DOORS OPERATOR

AUTOMATIC

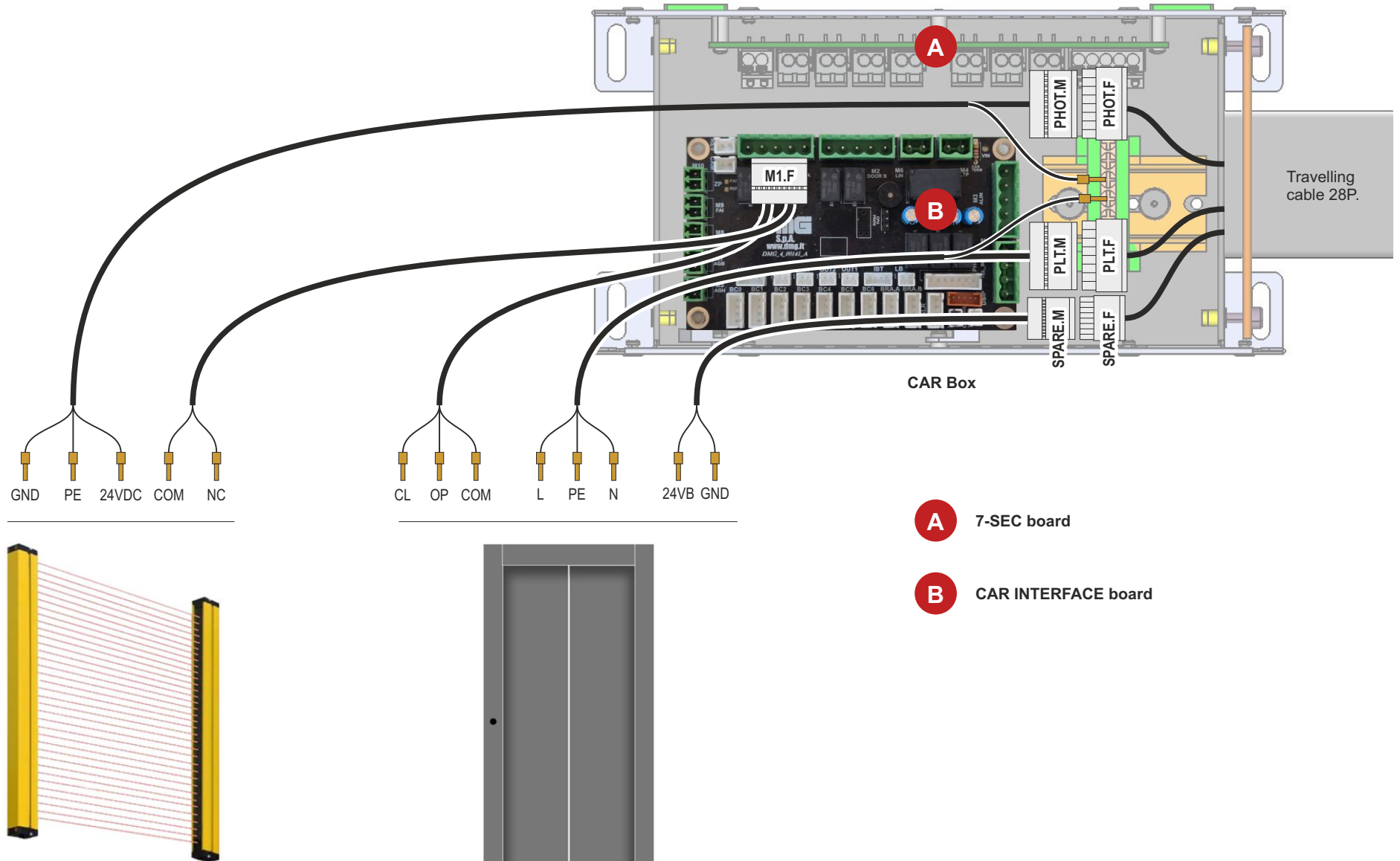

PRISMA AUTOMATIC

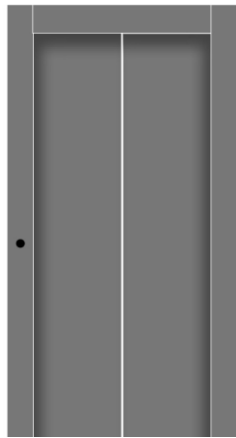
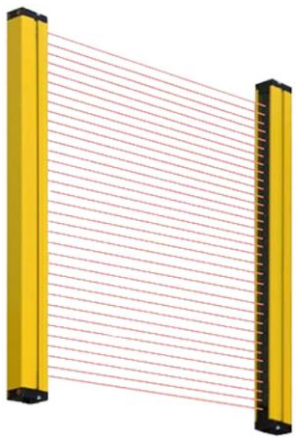
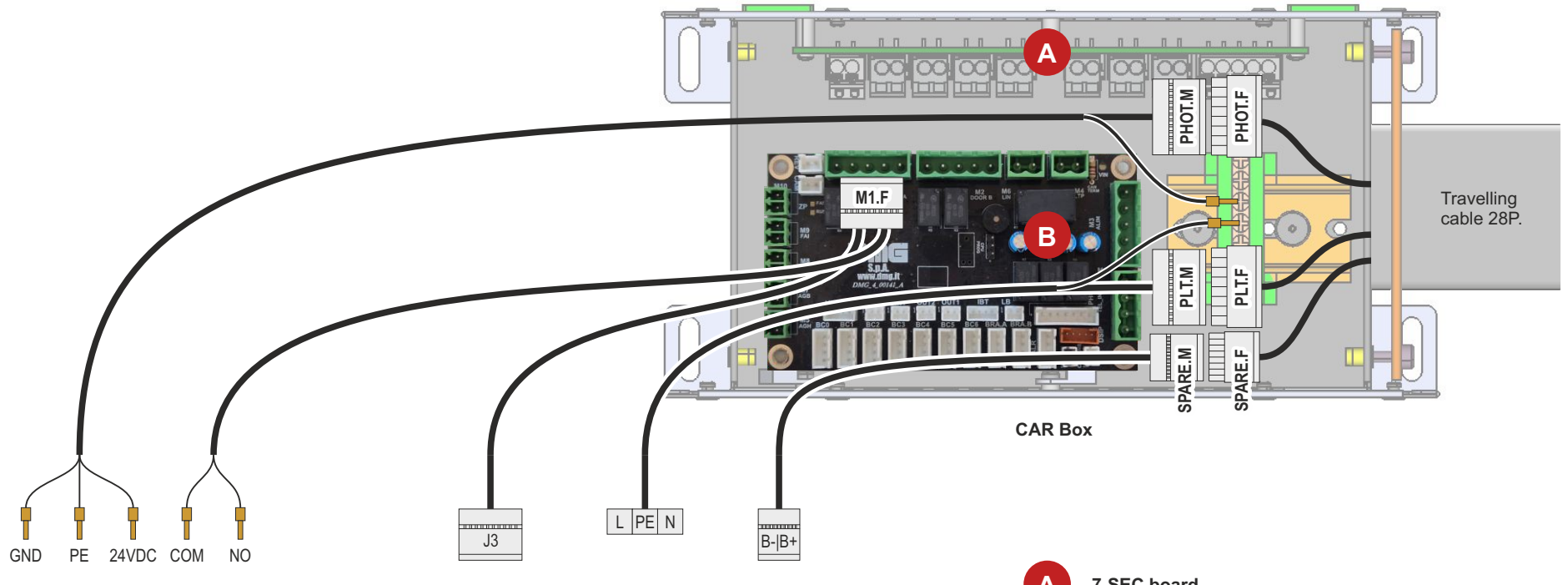

- A** 7-SEC board
- B** CAR INTERFACE board



## CONNECTING LIGHT BARRIERS (NO CAR DOORS)

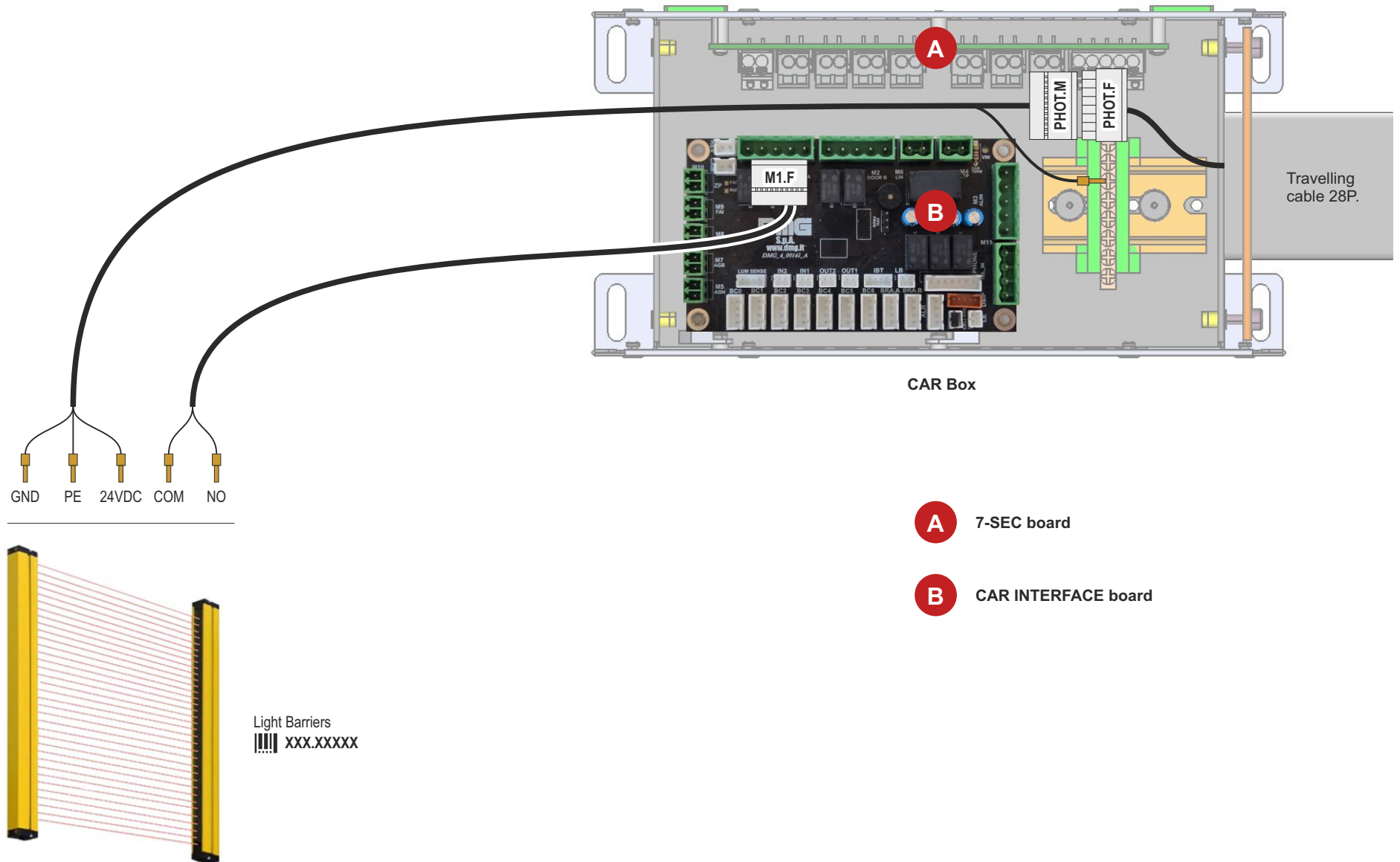

# CAR POSITION READING SYSTEM

## 1 REFERENCE LAYOUT FOR MAGNETS AND MAGNETIC READERS

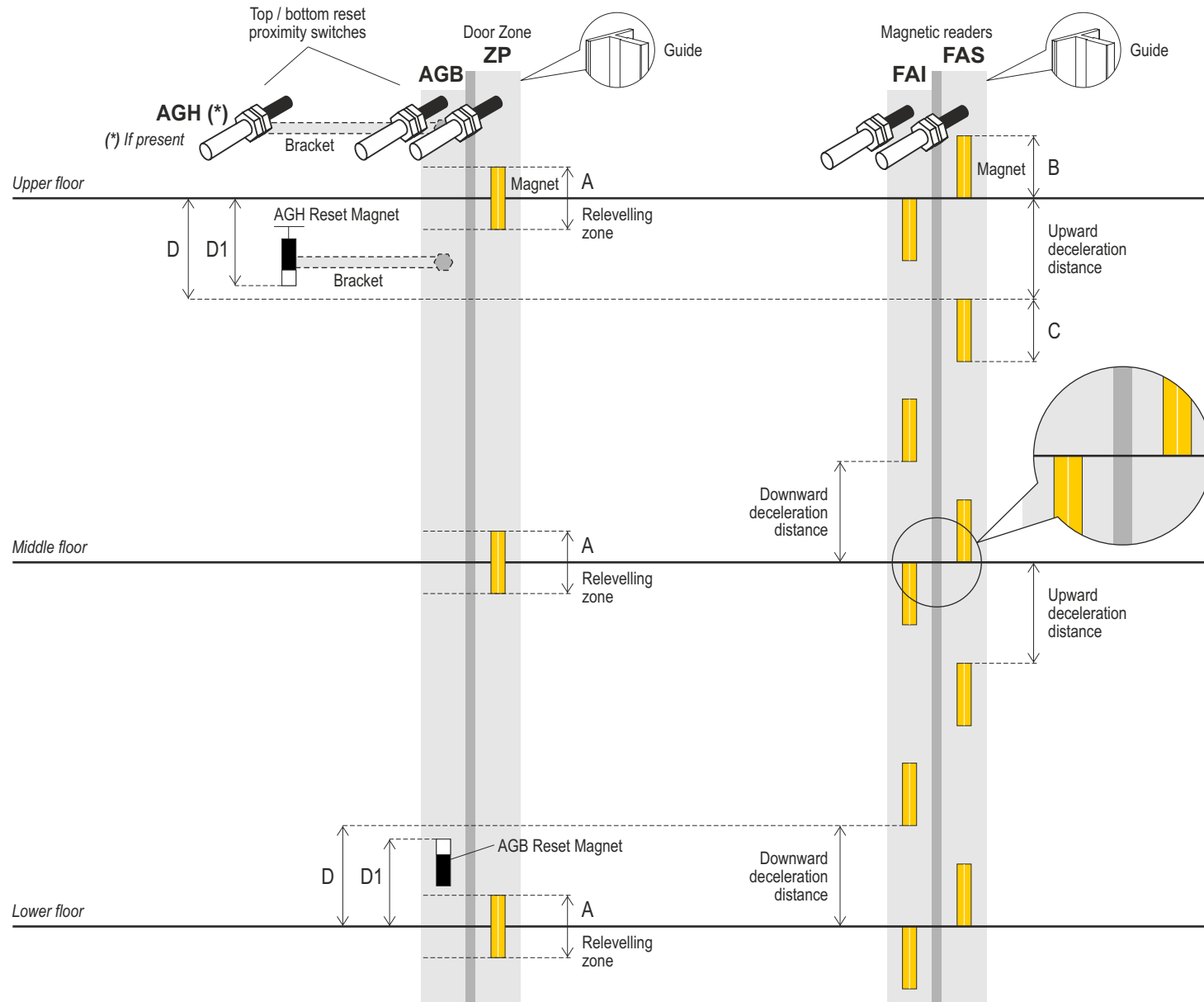

The deceleration magnets (C) can be shortened if necessary.

### Lengths (mm)

- A = 100
- B = 100
- C = 50 / 100

Speed (m/s)	D (mm)	D1 (mm)
0,15	250	D-20
0,30	400	D-20

### Installation KIT

#### QJ4.CTKIMP.H5

##### Magnetic Readers

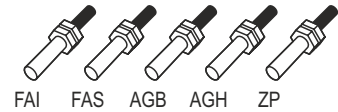

##### Reset Magnets



#### QJ4.CTKIMP.H4

##### Magnetic Readers

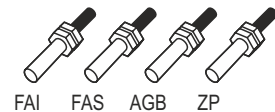

##### Reset Magnets



#### QJ4.SHCAL100

##### 1 Magnet



#### QJ4.SHSAFCR

##### 1 Bracket (optional)

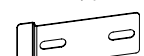

## 2 INSTALLING MAGNETS AND MAGNETIC READERS

### MAGNETIC READERS POSITIONING SYSTEM

#### FAI / FAS

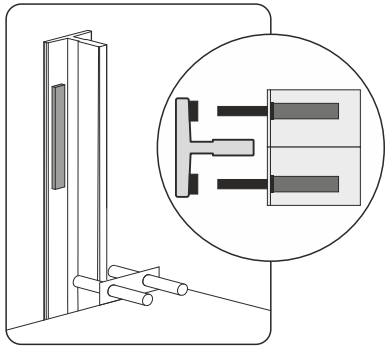

||||| QJ4.CTKIMP.H5 or ||||| QJ4.CTKIMP.H4

+

||||| QJ4.SHCAL100  
 4 magnets for the middle floors  
 2 magnets for the upper floor  
 2 magnets for the lower floor

### TOP / BOTTOM RESET PROXIMITY SWITCHES

#### AGB / AGH

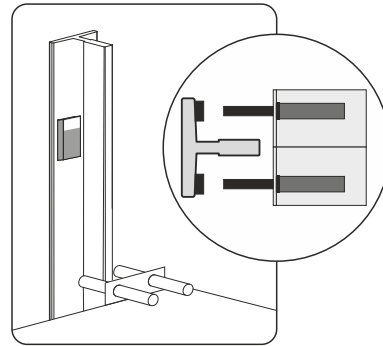

||||| QJ4.CTKIMP.H5

### BOTTOM RESET PROXIMITY SWITCH

#### AGB

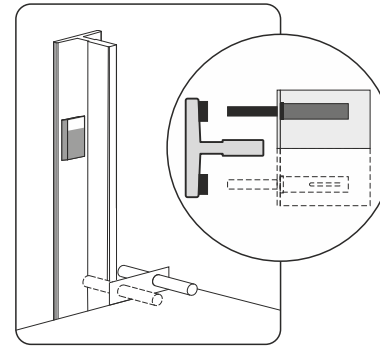

||||| QJ4.CTKIMP.H4

### DOOR ZONE / RELEVING

#### ZP

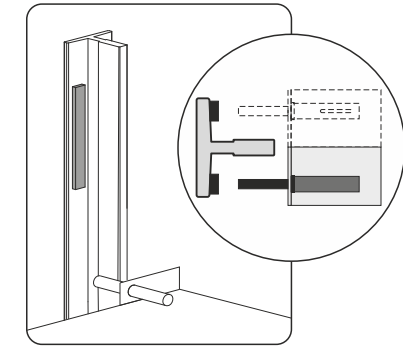

||||| QJ4.CTKIMP.H5 or ||||| QJ4.CTKIMP.H4

+

||||| QJ4.SHCAL100  
 1 magnet for each floors

## 3 CONNECTING THE MAGNETIC READERS

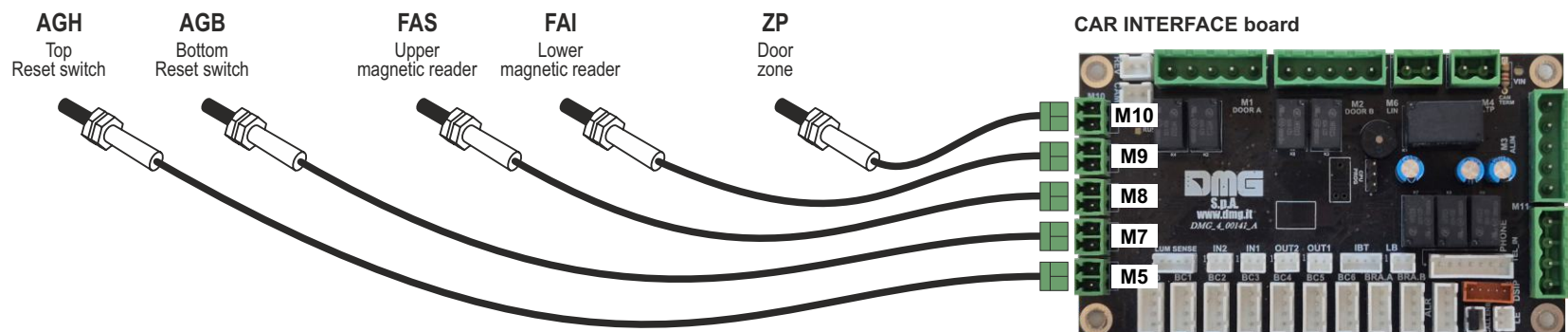

# CONNECTING THE CAR ILLUMINATION

12V DC

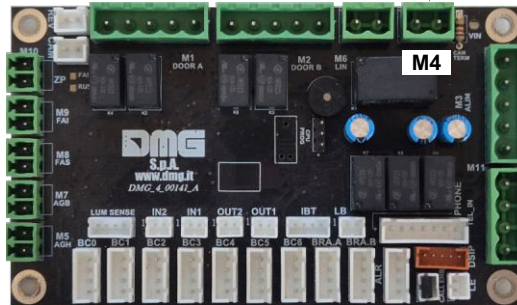
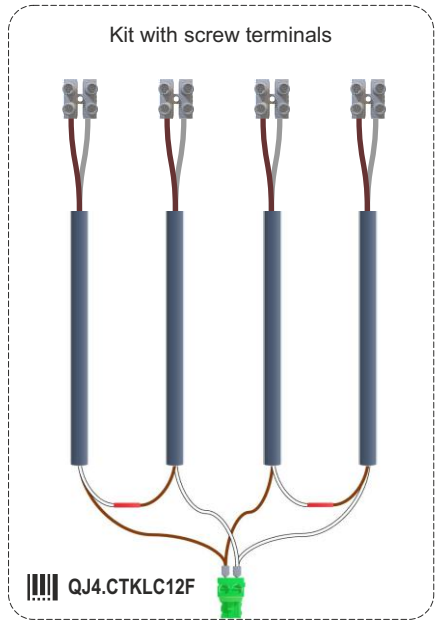
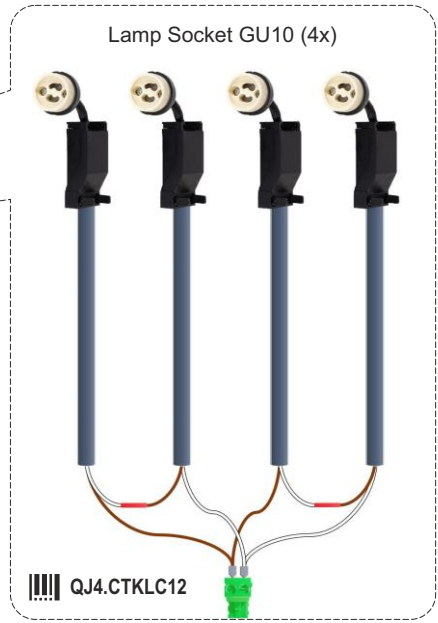
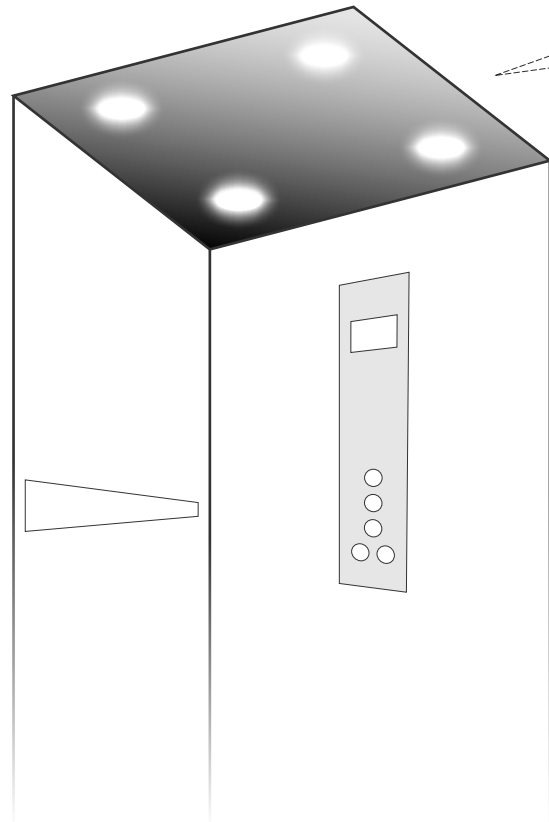

CAR INTERFACE board

230V AC

The positioning of this module is at installer's discretion

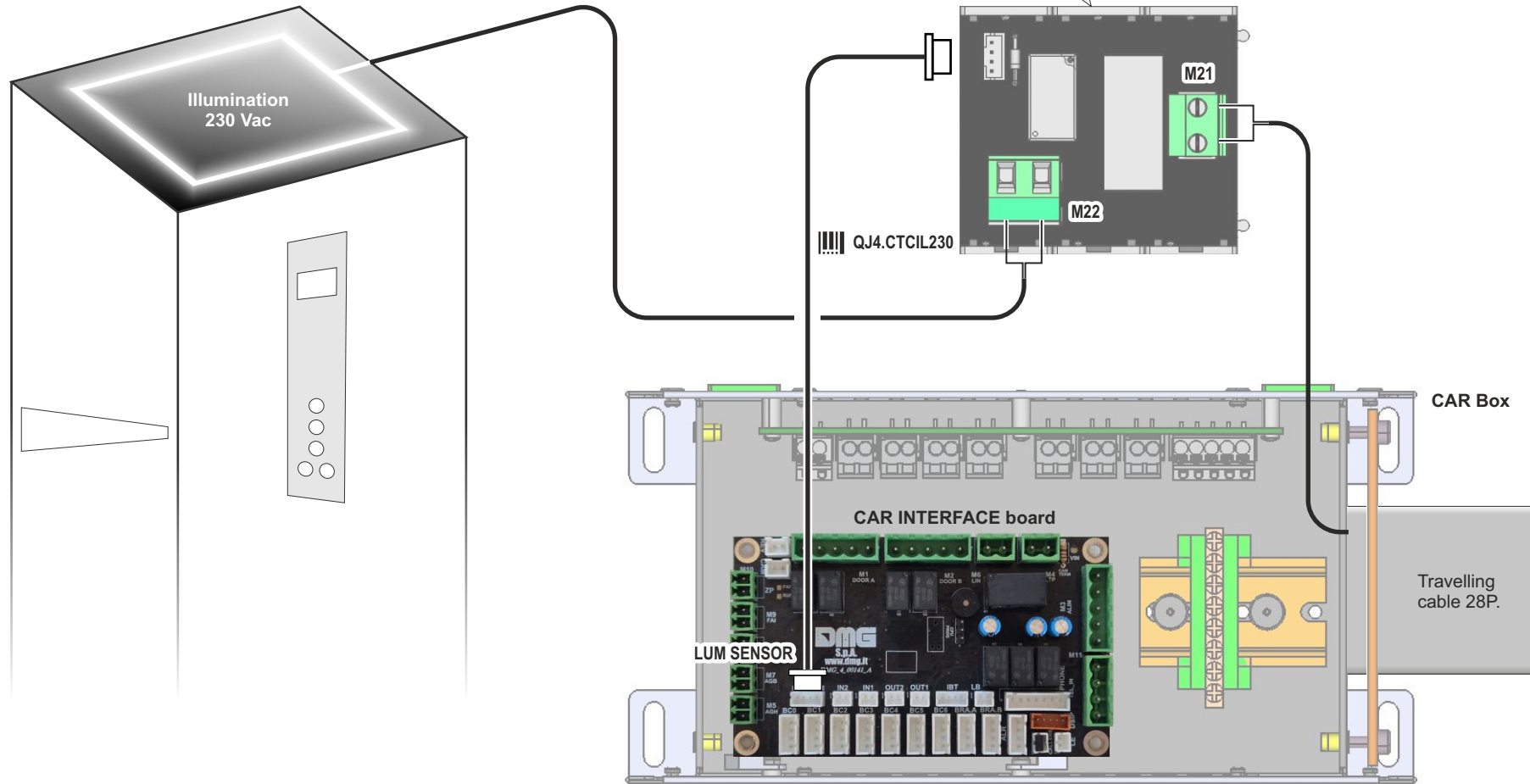

### CONNECTING THE INSPECTION BOX

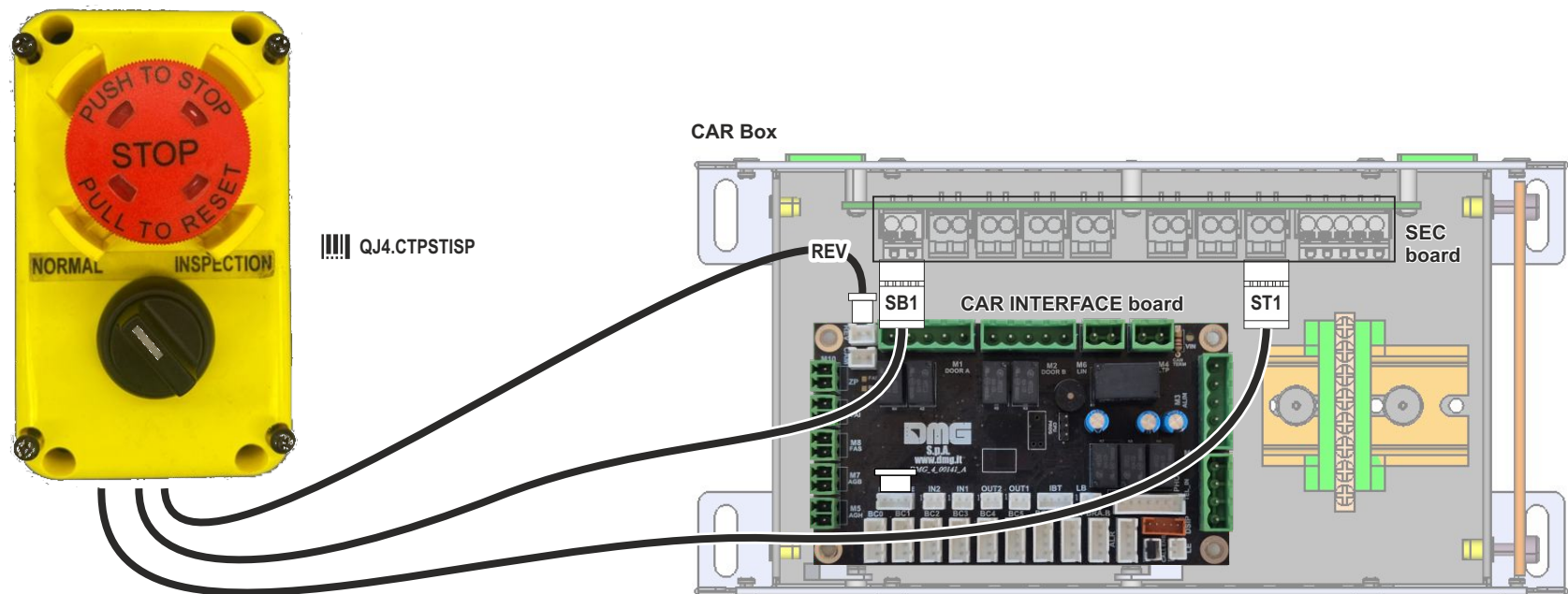
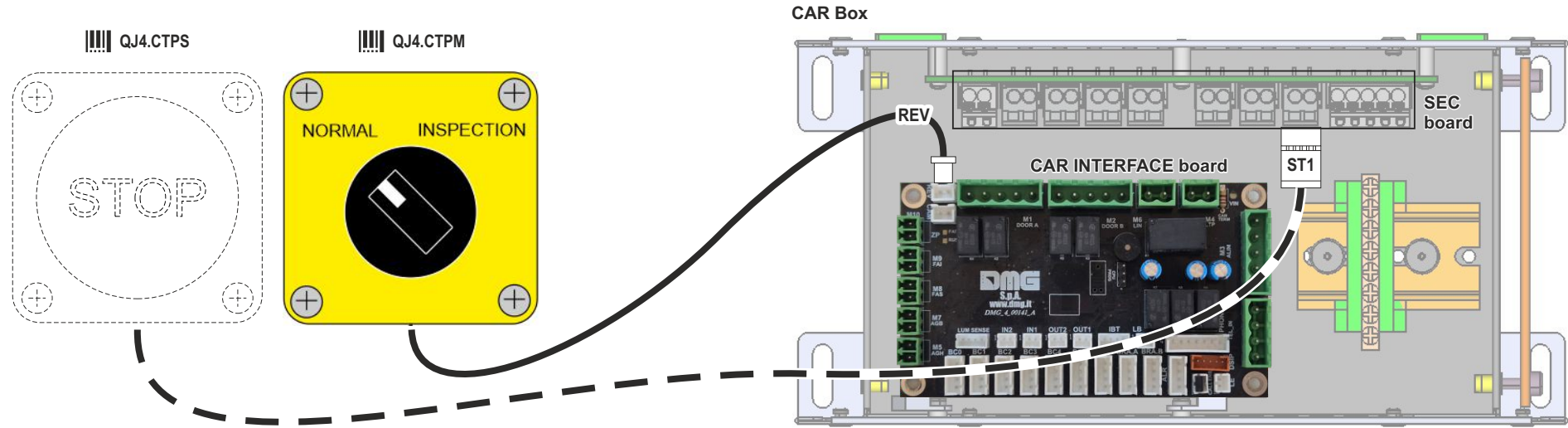



## INSTALLING THE CAR PANEL

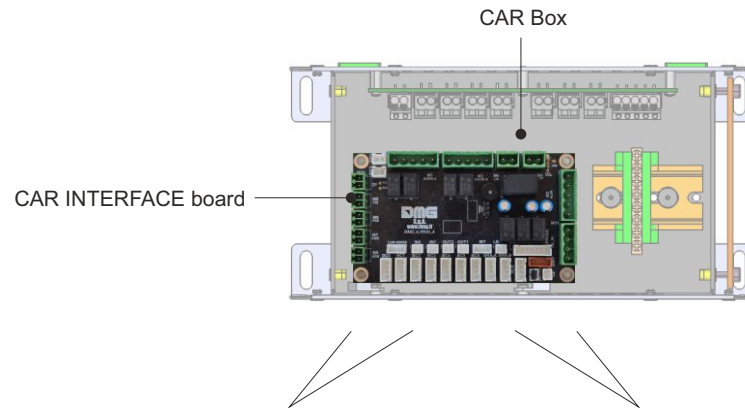

### DISPLAY & INDICATORS

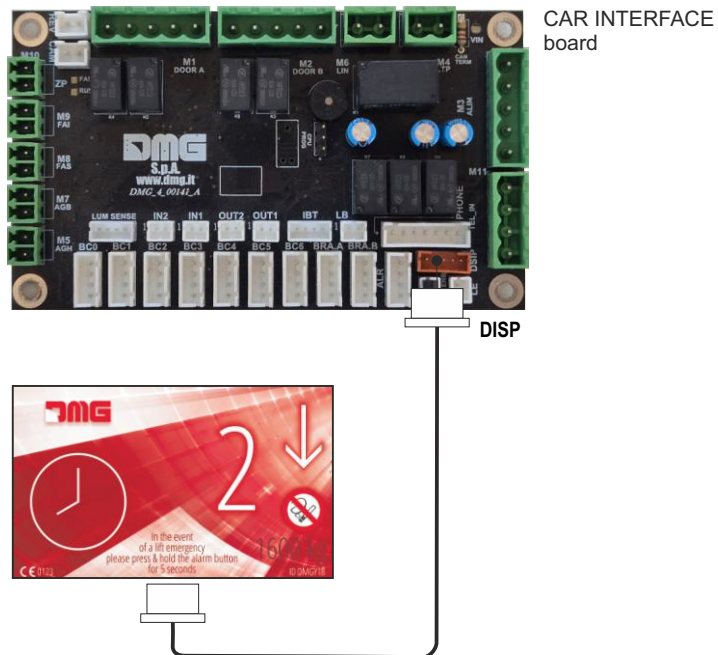

### CALL / SERVICE BUTTONS

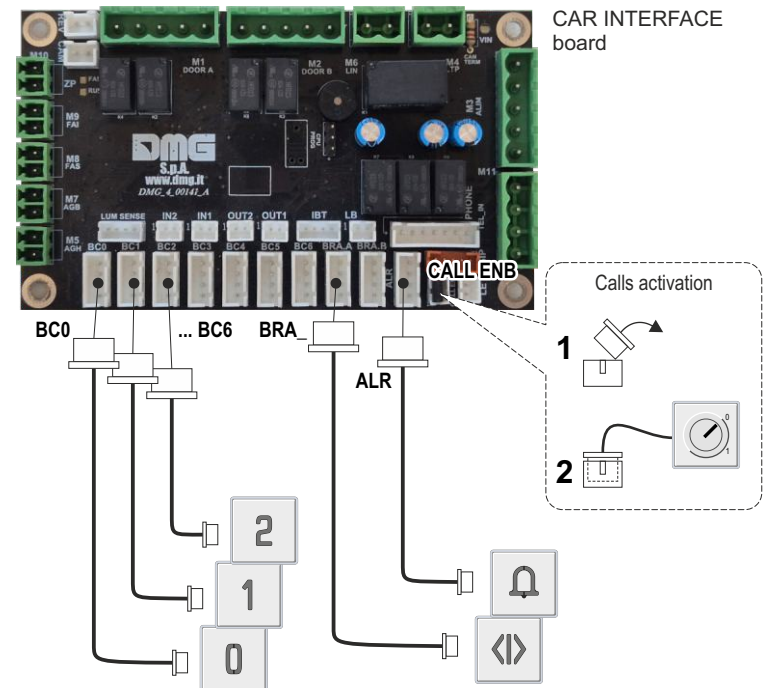

## INSTALLING THE FLOOR PANELS

Floor serial interface (BDU)

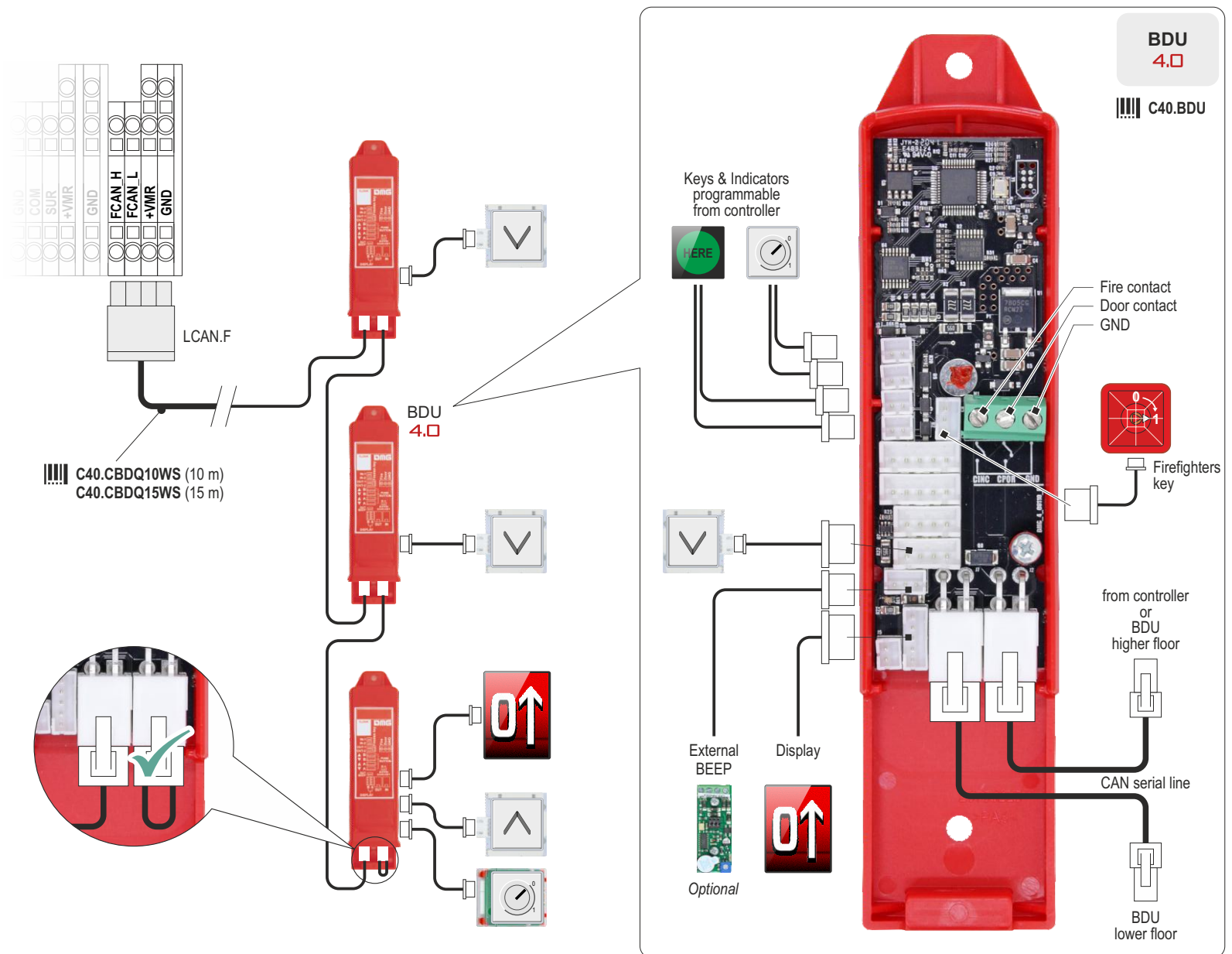

## INSTALLING THE EMERGENCY PHONE

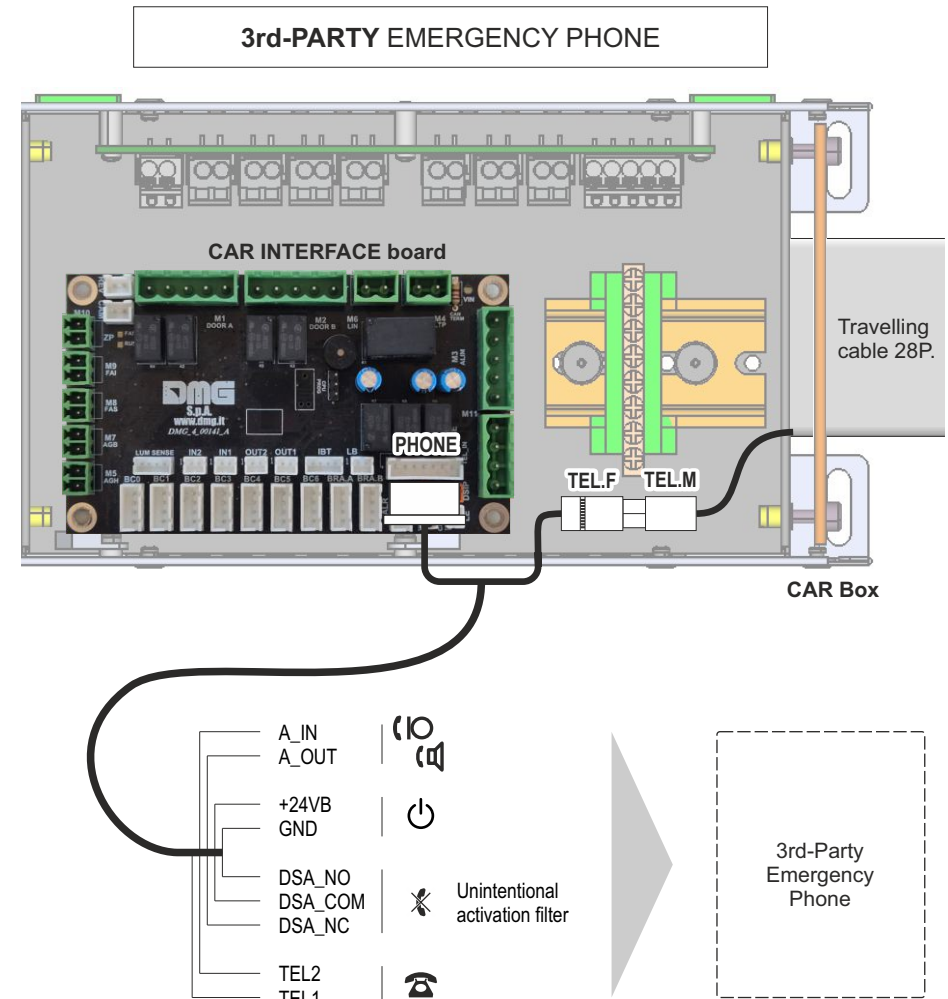
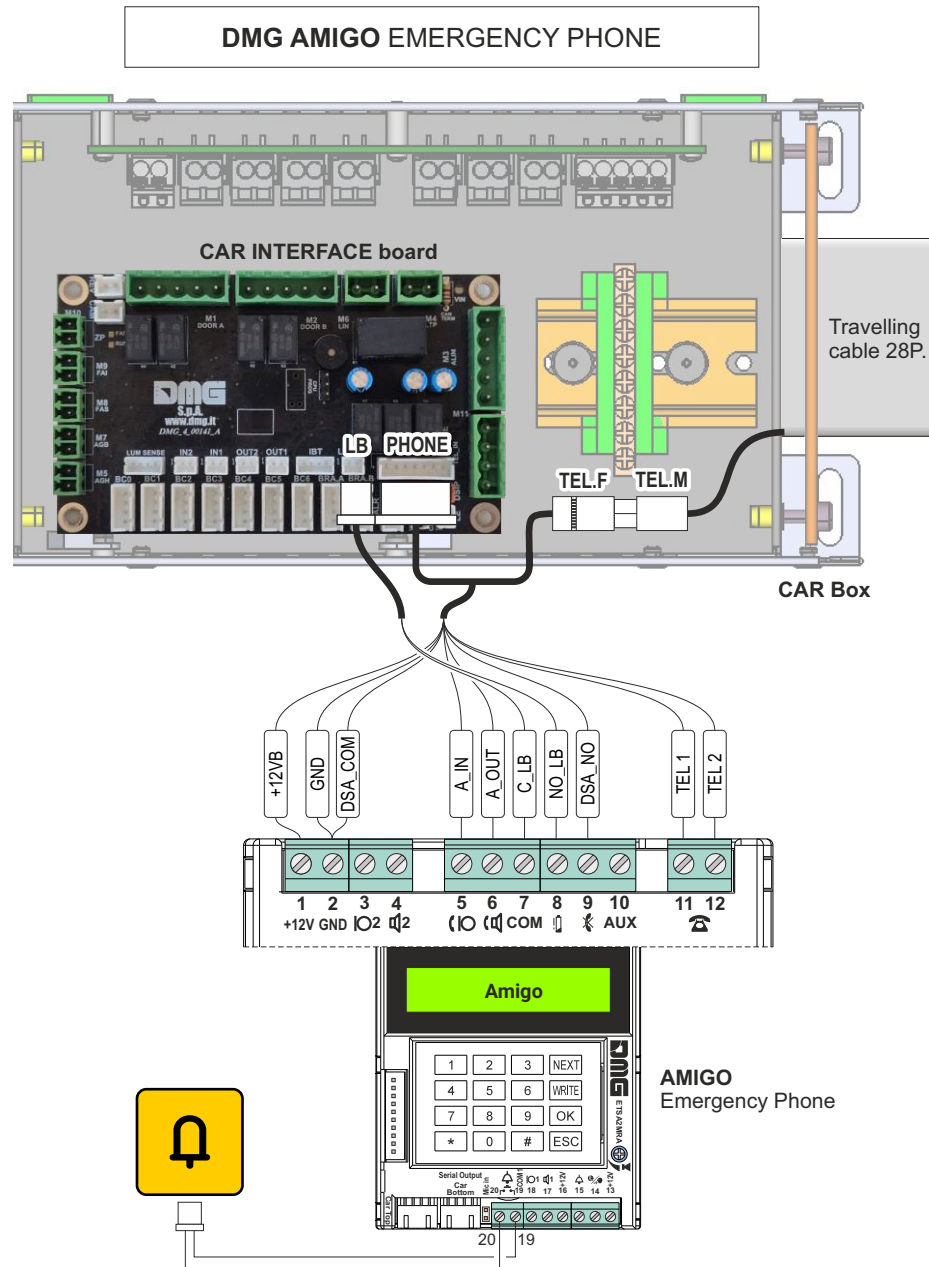

## PHASE 2 - NORMAL MODE & SYSTEM ADJUSTMENTS

### SWITCH TO NORMAL SERVICE MODE

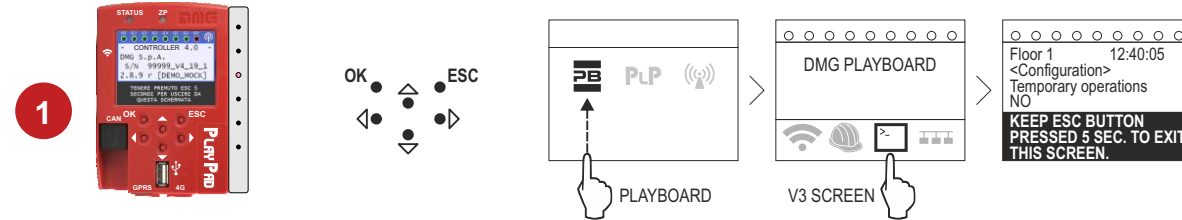

**2** Disconnect the temporary operations box

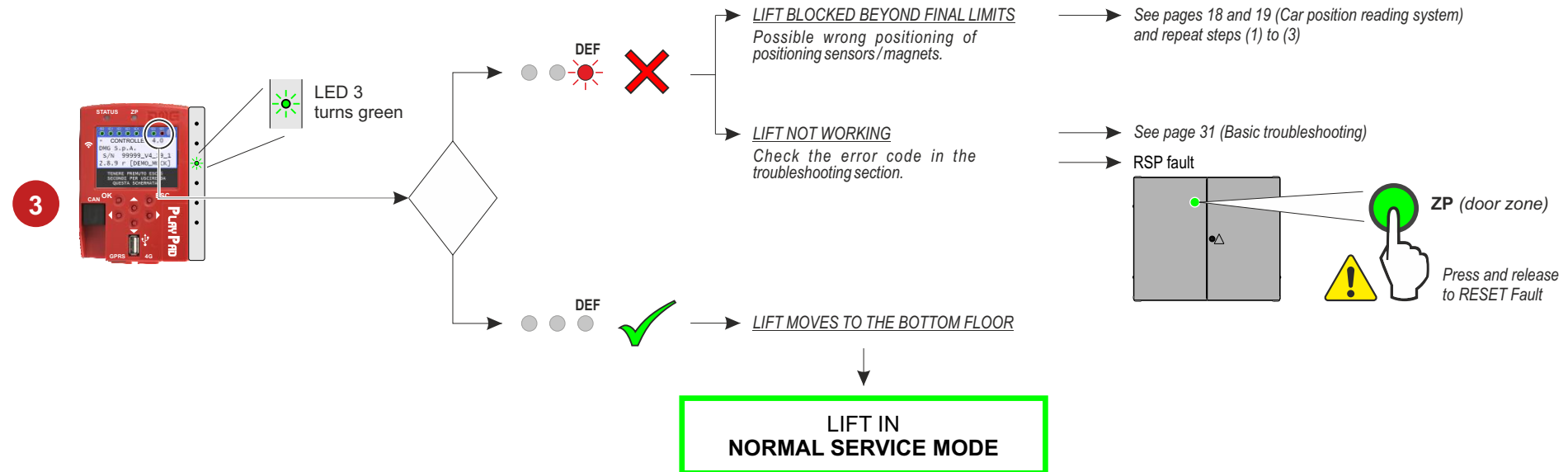

**4** Set the stopping accuracy (Fine tuning) at each floor  
 See next page

**5** Perform final system test  
 (check all lift functions)

## ADJUSTING FLOOR STOPPING ACCURACY

- 1 Read the gap between floor level and car floor edge.
- 2 Move **P** magnets in the shaft to adjust the stopping position.
- 3 Move **D** magnets to adjust the deceleration distance.

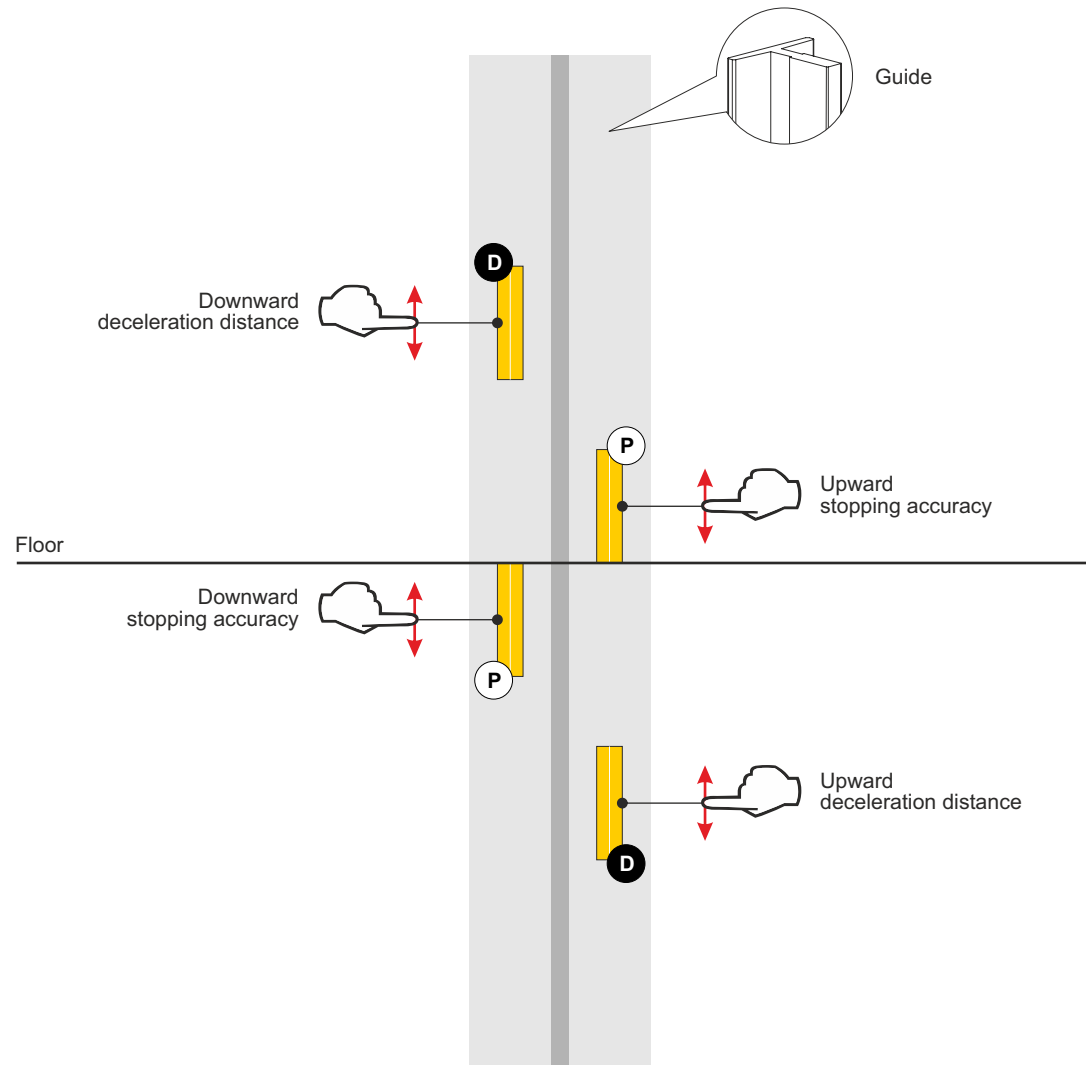

## CONNECTIVITY (FUSION APP)



Before even seeing how to connect and interact with the installed device, you need to access the Fusion Dashboard cloud software.  
<https://fusiondashboard.azurewebsites.net/>



On the Fusion Dashboard cloud, register the company, buildings, devices and operational technicians, as indicated in the video tutorials on the DMG DIDO site on the "Connectivity and Fusion app" page.  
<https://dido.dmg.it/knowledge-base/connectivity-fusion-app/>

### Connection mode

W-Fi connectivity to smartphones comes as a standard for all Junior 4.0 controllers, at no extra costs. To enable connectivity and benefits from the advantage of real-time monitoring of the lift, two solutions are available:



#### LOCAL connections

The local connection carry out on the installation site of the Pitagora system, via Wi-Fi HotSpot located in the TOC board and in the Junior 4.0.

Before connecting locally to the TOC and Playpad 4.0 devices via the Fusion app (described below), it is necessary to check that the Wi-Fi signal is enabled on these 2 devices.

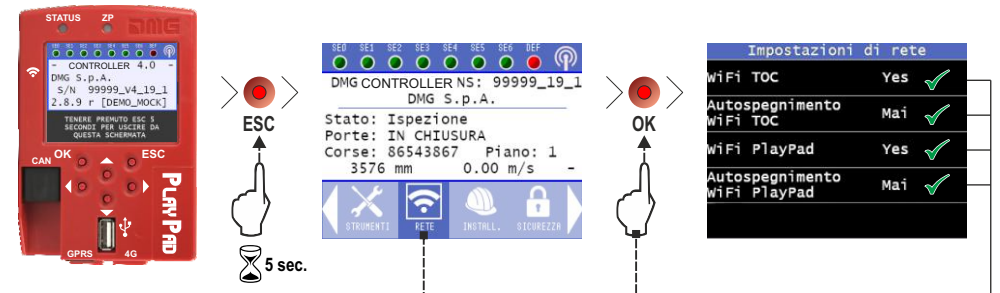

Wi-Fi hotspot must be enabled and the auto-off time of the Wi-Fi signal on the device (TOC / Playpad 4.0) must be sufficient for local operations.



#### REMOTE connections

The remote connection allows you to access the devices connected via Telemaco II 4G modem.

Telemaco II 4G is supplied without a SIM; the choice of the SIM is at discretion of the customer.

Instructions for installing the Telemaco II 4G modem:  
<https://dido.dmg.it/knowledge-base/telemaco-modem-4g-new/>





### Lift controller management via the Fusion app



Fusion is the application (IOS / Android) created by DMG for the direct management of compatible installed devices.

Download the Fusion app using the QR code on the side.



1



Start the FUSION app and login when the smartphone is still connected to internet.

You can reach devices locally without logging in (Select "Local Connection").

2



Select the type of device to manage.

3

#### Local connection

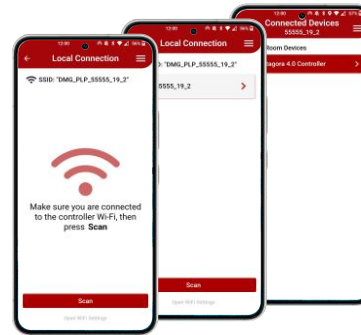

Make sure you are connected to the controller's Wi-Fi network:

- In the network settings of the smartphone, search and select the Wi-Fi network of the device to connect to (Playpad / TOC):
- DMG\_PLP\_xxx > PLAYPAD
- DMG\_TOC\_xxx > TOC

The login credentials are provided by DMG together with the documentation supplied with the product. Finally search for devices (press "Scan") and select the device to manage.

WiFi PLAYPAD	
	WiFi SSID DMG_PLP_11776_22_1
	WiFi Key xjyn\$VzRoe
WiFi TOC	
	WiFi SSID DMG_TOC_11776_22_1
	WiFi Key gh:p2e&_1

#### Remote connection

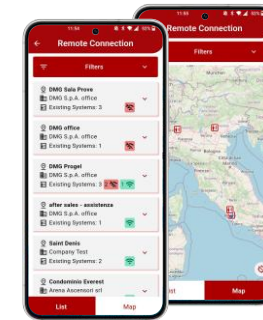

You can now choose the device to manage from either a device list or a device map.

4

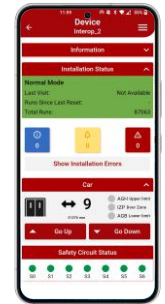

## TEST AND MEASUREMENTS

**MAIN PROTECTION SWITCH** OFF ON

The main switch of the controller must be switched off at every maintenance and at least 365 days after the last switch off and on.

To access the TESTS AND MEASUREMENTS section on the Playpad, set the display as indicated.

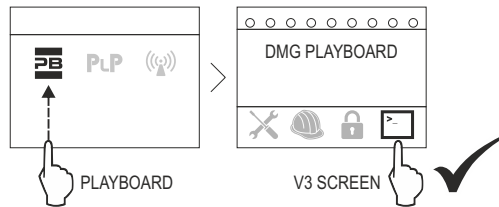
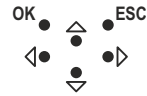

## FINAL LIMIT SWITCH TEST



*This test is only used to check the functionality and position of the final limit switch; this test does not check the behaviour of the car after leaving the final limit switch.*

- 1 TOP floor
- 2 Floor X 12:30:56  
<Configuration> Test  
TEST 7
- 3 INSPECTION
- 4 Final limit switch (OUT)
- 5 Floor X 12:30:56  
<Faults>  
Faults: 1  
Reset FCO ?  
Reset Fault
- 6 Repeat 1 ÷ 5 but at the BOTTOM floor

## RE-LEVELLING TEST

- 1
- 2 Floor X 12:30:56  
<Configuration> Test  
TEST 5
- 3 Floor X 12:30:56  
<Configuration> Test  
TEST 6
- 4 Repeat 1 ÷ 3 at every floor

## BASIC TROUBLESHOOTING

Follow this first-level procedure to detect and remove the most common faults:

### 1 Check Diagnostic LEDs (VVVF unit)



LED 1	LED1 (Green led):	NOT used
LED 2	LED2 (Green led):	CAN Cabin termination active: led switch off when an optional board (PIT8 / 16IO / 16RL) is connected to the controller (termination automatically moves on last optional board).
LED 3	LED3 (RGB led):	System status Led (see table):
LED 4	LED4 (Yellow led):	Led blinks when board is running.
LED 5	LED5 (Green led):	Led on gives the status of SE5 safety chain
LED 6	LED6 (Red led):	Led on gives the status of SE5 safety chain

<u>Led Color</u>	<u>Status</u>
Led Off	The system is performing the reset procedure
Green	The system is in normal operation mode
Yellow	The system is in inspection mode
Pink	The system is in temporary operations mode
Purple	The system is out of service (parking of cabin)
Cyan	The system is running in priority mode (LOP / CAR)
Red	The system is operating in Fire-fighters mode
White	The system is performing the emergency procedure
Blue	The system is performing the elevator car drift control procedure

Led Off	No fault active
Led Flashing	One (or more) fault active
Led On	Locking fault active

### 2 Read error messages on the PlayPad error menu / Fusion error page

Floor 0 12:30:56  
< Faults >



Floor 0 12:30:56  
< Faults >  
Faults : XX  
Display ?



- Error X of XX total.
- **Code/description error.**
- Car position when the fault was detected.
- Number of repetitions of the same error.
- Additional code.
- Date and time of last detection.
- (\*) If the error is still active.

This Menu lists the last faults stored into the internal memory of the controller. All faults are described in the **Troubleshooting guide**. See leaflet on the back of this guide.

**WARNING:** In case of black out, the internal memory is saved only if the battery is connected.

### 3 If the car is blocked with people inside

Perform the RESCUE OPERATION as shown on the following page ----- >>>

## RESCUE OPERATION FOR HYDRAULIC LIFTS

IF THE CAR IS BLOCKED ---->



After pressing the ZP button (door zone) you have 1 hour (default) to carry out the maneuver. If the procedure takes longer, press it again.

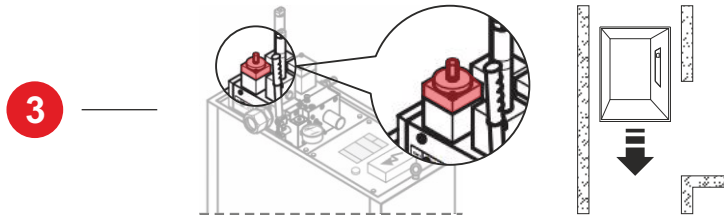
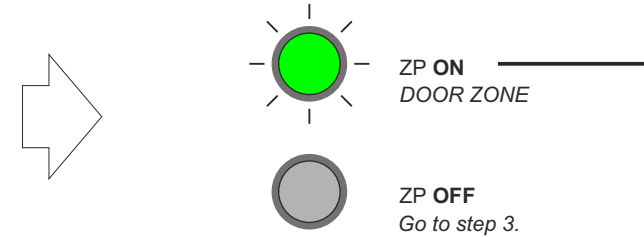
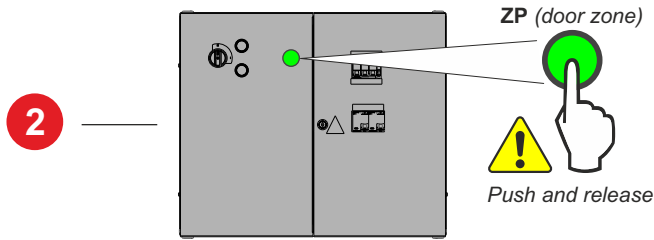

Press and hold the button on the hydraulic unit to move the cabin down.

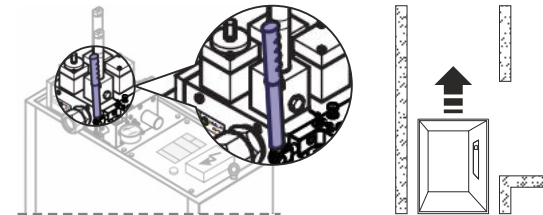

Use the hand pump lever to move the cabin up.

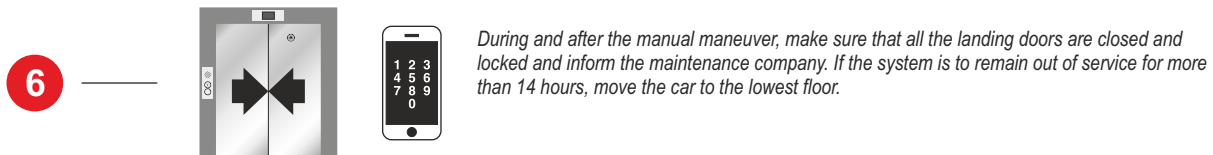
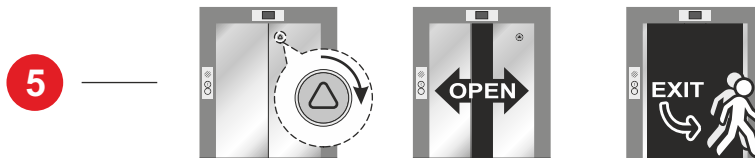

## ADVANCED SETTINGS



### 1 Defining the position of the main floor

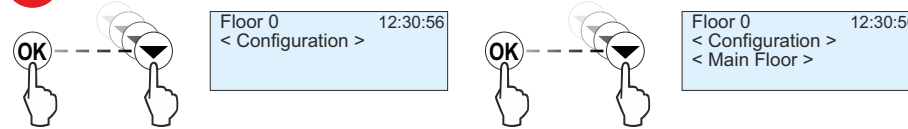

- All calls below this floor are served only upwards (only down collective).
- Lift not in use goes to Main Floor after xx seconds (this parameter can be set in the menu "Special features > Automatic return")

### 2 Setting date / time

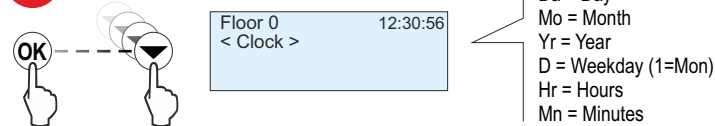

### 3 Defining a protected floor

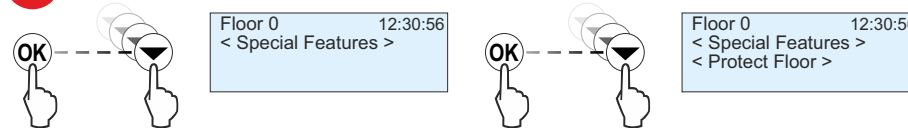

If a protected floor is programmed, when the elevator car reaches the floor, the door does not open, instead the monitor will show images coming from the camera corresponding to that floor. Doors can be opened only by pressing the OPEN DOOR button; if this does not happen, the lift moves to the previous floor and then stops the protected floor mode (this operating mode is only possible with DMG's monitoring system).

### 4 Changing door assignment / layout

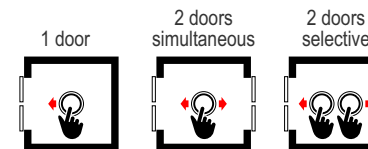
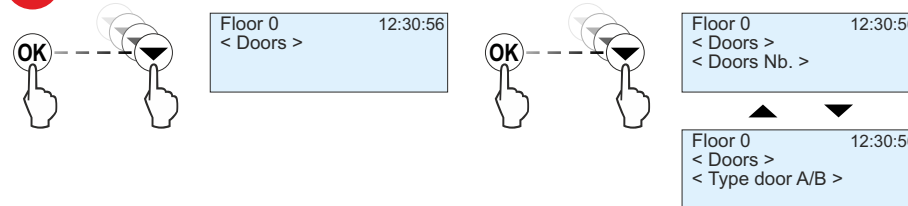

- Manual doors at floors / car doors manual or not present.
- Manual doors at floors / car doors independent.
- Manual doors at floors / car doors automatic.
- Automatic doors at floors and in the car.

### 5 Adjusting door parameters

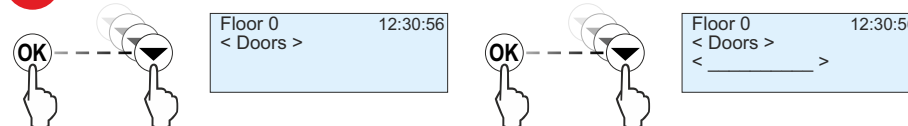

In the "Doors" menu it is possible to manage other parameters such as:

- Time before activation of the retiring ramp and the lock fault
- Time before door opening
- Life car parking time with open doors
- Time before door closes in case of registered calls
- Many other settings



**DMG SpA** • Via delle Monachelle, 84/C • 00071 POMEZIA (ROMA) - ITALIA  
Tel. +39 06930251 • [www.dmg.it](http://www.dmg.it)