



**DMG**

**JUNIOR 4.0**  
**VVVF Gearless**

**Quick installation guide**

*English*

V 2.1

## INDEX

|                |   |               |
|----------------|---|---------------|
| <b>PHASE 0</b> | <b>INSTALLATION OF BASE ELEMENTS</b> .....                          | <b>pg. 6</b>  |
|                | INSTALLING THE CONTROLLER .....                                     | pg. 6         |
|                | CONNECTING THE MAIN POWER SUPPLY .....                              | pg. 7         |
|                | CONNECTING MOTOR OUTPUTS .....                                      | pg. 8         |
|                | FIXING THE TRAVELLING CABLE .....                                   | pg. 9         |
|                | CONNECTING THE TRAVELLING CABLE TO THE CAR DISPATCHING BOARDS ..... | pg. 9         |
| <b>PHASE 1</b> | <b>TEMPORARY MODE &amp; ELECTRICAL CONNECTIONS</b> .....            | <b>pg. 10</b> |
|                | TEMPORARY OPERATIONS .....  | pg. 10        |
|                | MOTOR DATA SELF-LEARNING PROCEDURE .....                            | pg. 11        |
|                | INSTALLING THE SAFETY CHAIN .....                                   | pg. 12        |
|                | CONNECTING CAR DOORS OPERATOR .....                                 | pg. 14        |
|                | CONNECTING LIGHT BARRIERS .....                                     | pg. 18        |
|                | CAR POSITION READING SYSTEM .....                                   | pg. 19        |
|                | CONNECTING THE CAR ILLUMINATION .....                               | pg. 21        |
|                | CONNECTING THE INSPECTION BOX .....                                 | pg. 24        |
|                | INSTALLING THE CAR PANEL .....                                      | pg. 25        |
|                | INSTALLING THE FLOOR PANELS .....                                   | pg. 26        |
|                | BDU PROGRAMMING .....   | pg. 27        |
|                | INSTALLING THE EMERGENCY PHONE .....                                | pg. 28        |
|                | INSTALLING THE LLEC7 LIFT LOAD ELECTRONIC CONTROL DEVICE .....      | pg. 29        |
| <b>PHASE 2</b> | <b>NORMAL MODE &amp; SYSTEM ADJUSTMENTS</b> .....                   | <b>pg. 30</b> |
|                | SWITCH TO NORMAL SERVICE MODE .....                                 | pg. 30        |
|                | ADJUSTING FLOOR STOPPING ACCURACY .....                             | pg. 31        |
|                | CONNECTIVITY (FUSION APP) .....                                     | pg. 32        |
|                | TESTS .....   | pg. 34        |
|                | BASIC TROUBLESHOOTING .....   | pg. 37        |
|                | RESCUE OPERATION FOR TRACTION LIFTS .....                           | pg. 38        |
|                | ADVANCED SETTINGS .....   | pg. 39        |

## JUNIOR 4.0 - ELECTRIC SYSTEM FOR HOMELIFTS

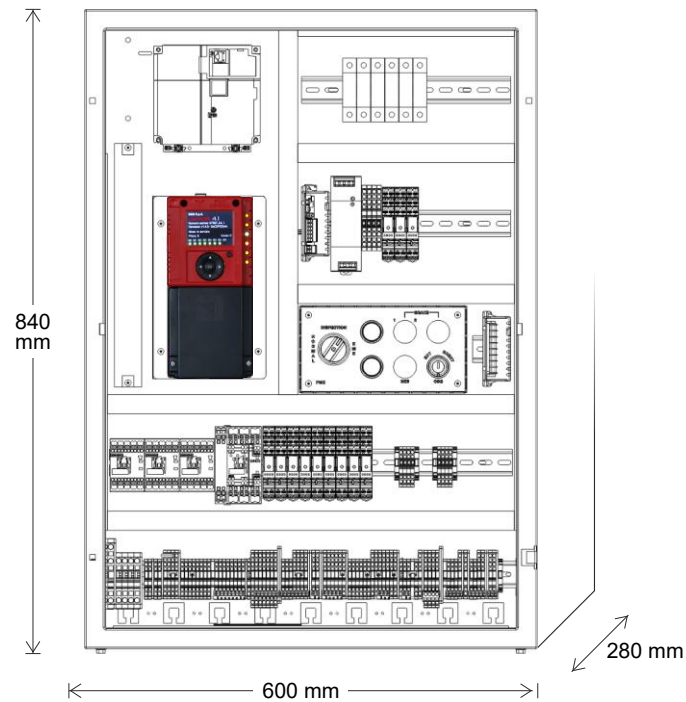

**M** Gearless: 2,2kW

600x840x280 mm

~ 30 kg

✓ Single Phase

✓ 7 stops max.

**EN**  
81-41

**pr EN**  
81-42



### SAFETY NOTES

#### Installation

The control panel must be installed internally with a degree of pollution of not more than 2. The cabinet has an IP2X degree of protection.

The controller setup and maintenance has to be made by qualified technicians after having carefully read the documentations and electrical schemes provided with the controller.

Protection toward indirect contacts has to be realized through magnetothermic and differential switches and a grounding system. Unless otherwise specified, the customer is requested to provide these protections.

Please refer to the wiring diagram supplied with the control panel for the following protection circuits:

- magnetotermic protection of the motor circuit
- magnetotermic protection of the safety circuit
- protection fuses of all other circuits

Protection measures against electric shock:

- The control panel case of the is metallic and must be grounded as indicated in the circuit diagram supplied with the control panel.
- The command and control circuits (24V) are galvanically separated from the main power supply as indicated in the wiring diagram supplied with the control panel.

#### Maintenance

For control panel's maintenance, please refer to the manual supplied with the control panel. During periodic inspections of the system, check the alarm circuits' battery status of the and the floor return circuit (if present). Refer to the packaging instructions to handle and move the control panel.

### 7-SEC SAFETY MODULE

#### Description

SECU.24 module is an electronic device installed in DMG lift control panel that allows to check the status of 7 point of the safety chain of the lift.

The main function of this module is to guarantee galvanic isolation between the safety circuit and the electronic circuits of the control panel.

There is only one version of this module available:

- SECU.24 for control panel with safety circuit powered at 24 V DC [-15 / + 10%]

#### Installation

The SECU.24 module is supplied by DMG already installed and connected in the control panel. No intervention by the installer is required during commissioning of the control panel.

The common of the connections to the electric safety chain is traced on the printed circuit board in such way, that the common to the contactors or relay-contactors will switch off at interruption of the common (CBC(1) / CBC(9)).

#### Working conditions

The SECU.24 module is installed in a metal earthed cabinet with minimum IP20 protection and fixed on a DIN rail at following service condition:

- Indoor Use.
- Temperature: -5°C / +40°C
- Relative Humidity: must not exceed 50% at a max temperature of +40°C; may increase at lower temperatures, for example, can be 90% at 20°C.

#### Maintenance

In the event of a fault, the device must be replaced, it must not be opened or repaired.

If LM2A/C inverter is present, restart the controller once a year.

## SYSTEM LAYOUT

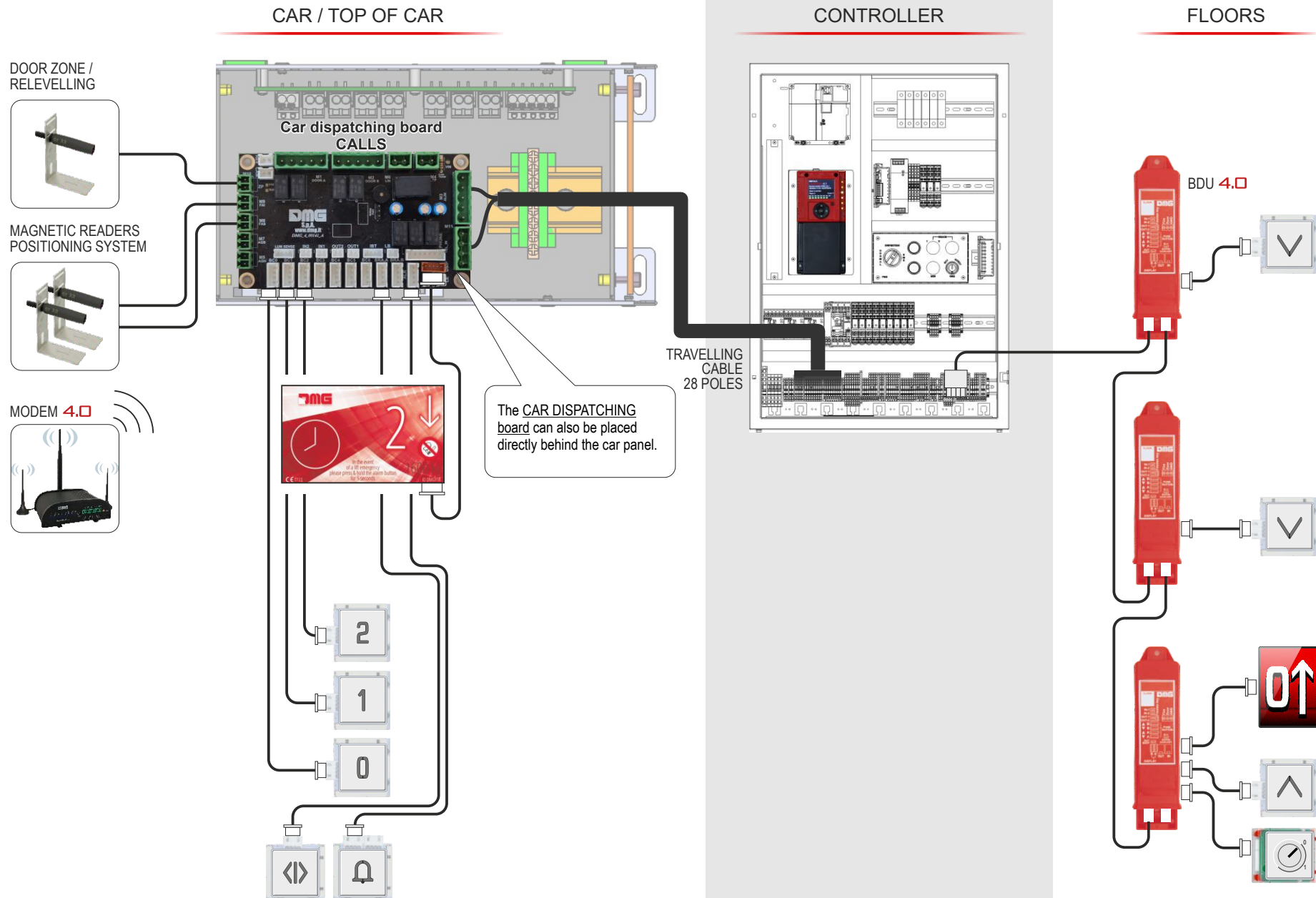

## COMPONENTI DEL SISTEMA

### TOP OF CAR

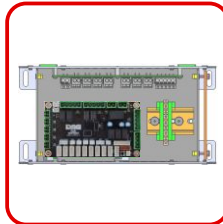
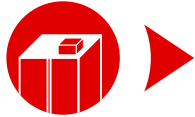

**||||| QJ4.CTBOXS**  
Car dispatching boards  
(in the top of car box)



**||||| QJ4.C28CS**  
Travelling cable kit (x m)

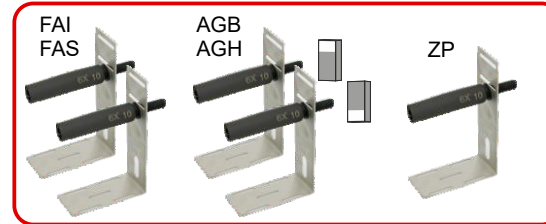

**||||| QJ4.CTKIMP.H5 / QJ4.CTKIMP.H4** (without AGH)  
Magnetic readers positioning system + door zone/relevelling  
+ top/bottom reset proximity switches and reset magnets

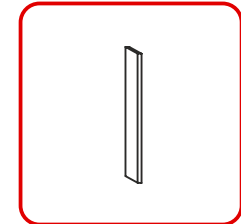

**||||| QJ4.SHCAL100**  
1 magnet  
**||||| QJ4.KSHCAL**  
1 x 200mm  
4 x 150 mm

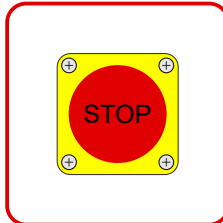

**||||| QJ4.CTPS**  
Top of cabin stop

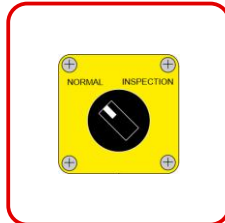

**||||| QJ4.CTPM**  
Inspection box



**||||| QJ4.CTPSTISP**  
Inspection box + Stop

### CAR

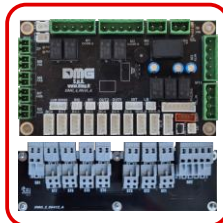

**||||| QJ4.CTSTI**  
Car dispatching boards  
(behind car panel)

### SHAFT

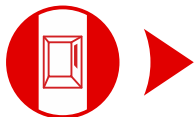

**||||| QJ4.SHEX1/2**  
Final limit switch kit



**||||| QJ4.SHP\_ / QJ4.SHC\_**  
Safety chain (doors / pit)



**||||| QJ4.SHPSH**  
Pit stop



**||||| C40.BDU**  
Floor interface (BDU)



**||||| QJ4.SHLED\_F05 / F15**  
+ **QJ4.SHLED\_V**  
Shaft illumination kit (5 / 15 m)

**PHASE 0 - INSTALLATION OF BASE ELEMENTS**  
**INSTALLING THE CONTROLLER**

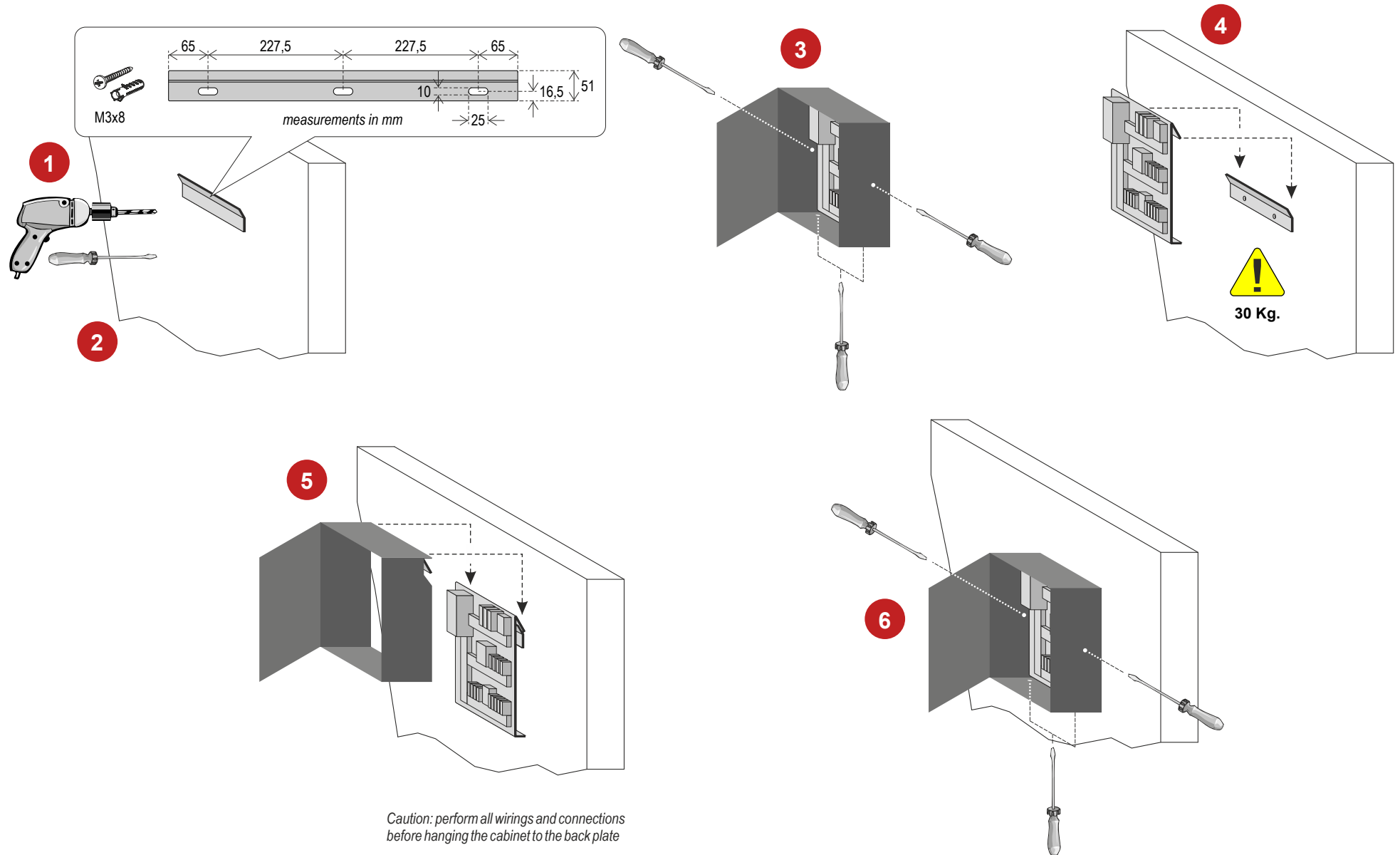

# CONNECTING THE MAIN POWER SUPPLY

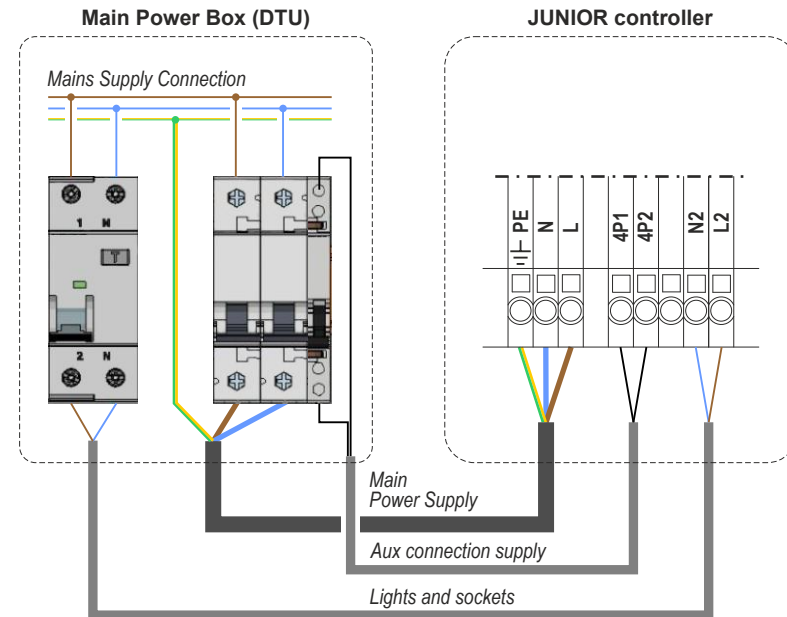
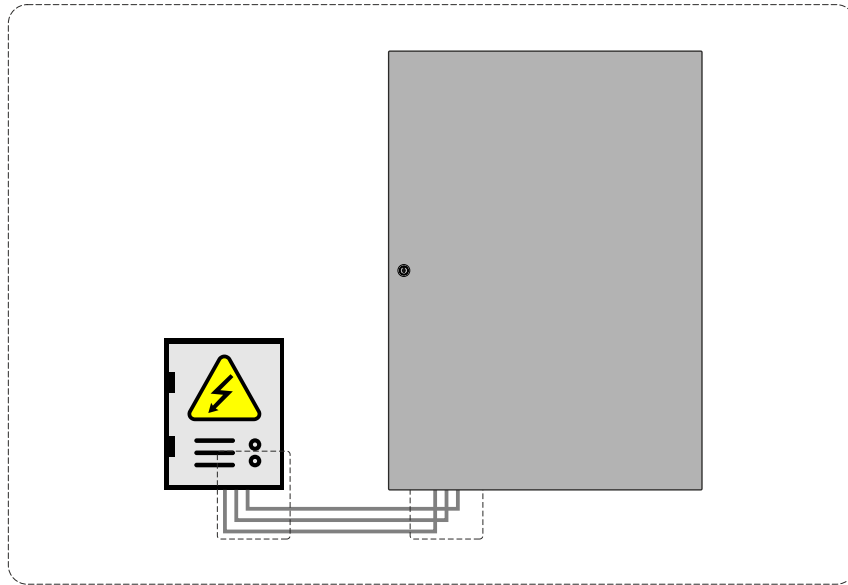

## CONNECTING MOTOR OUTPUTS

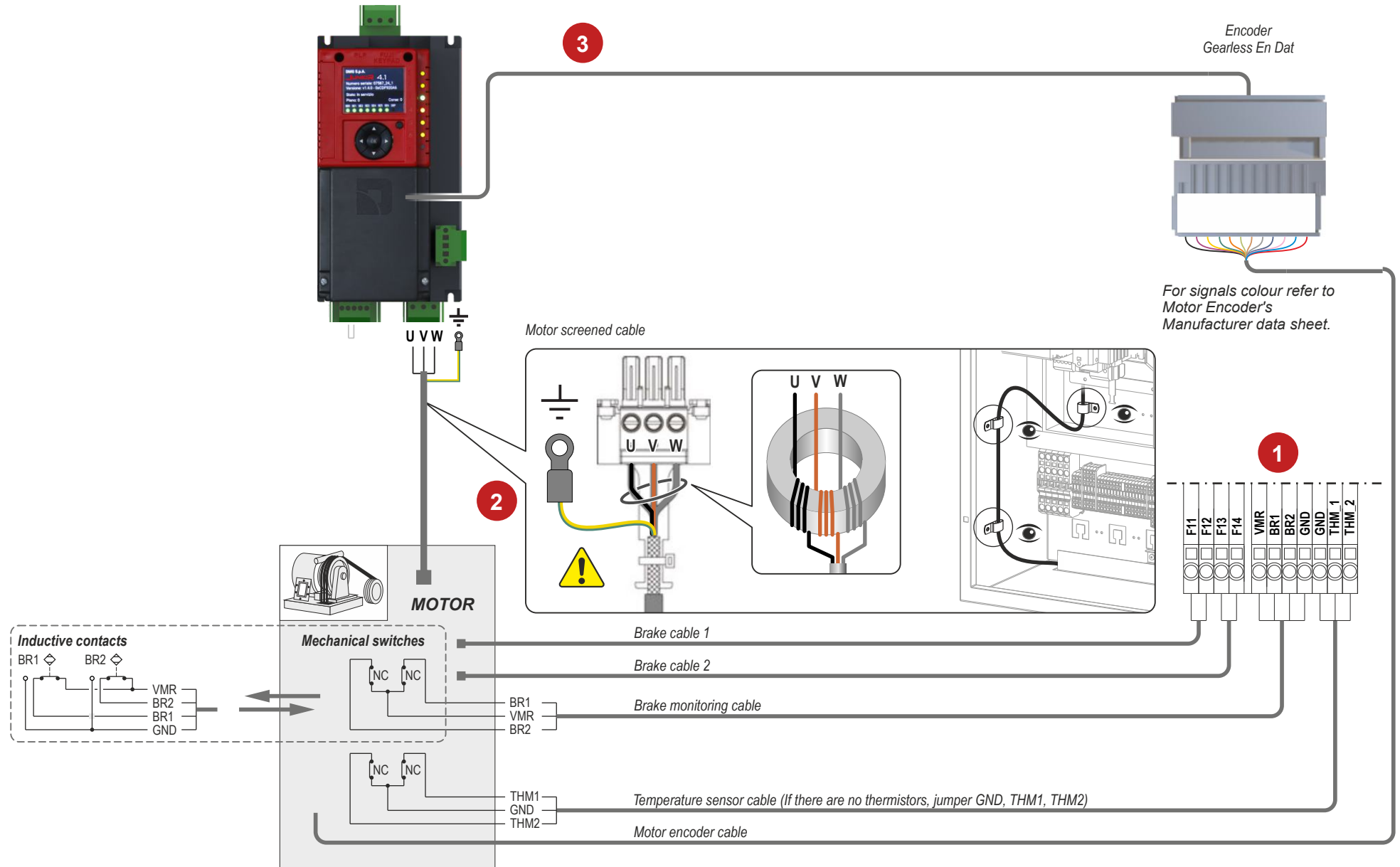

## FIXING THE TRAVELLING CABLE

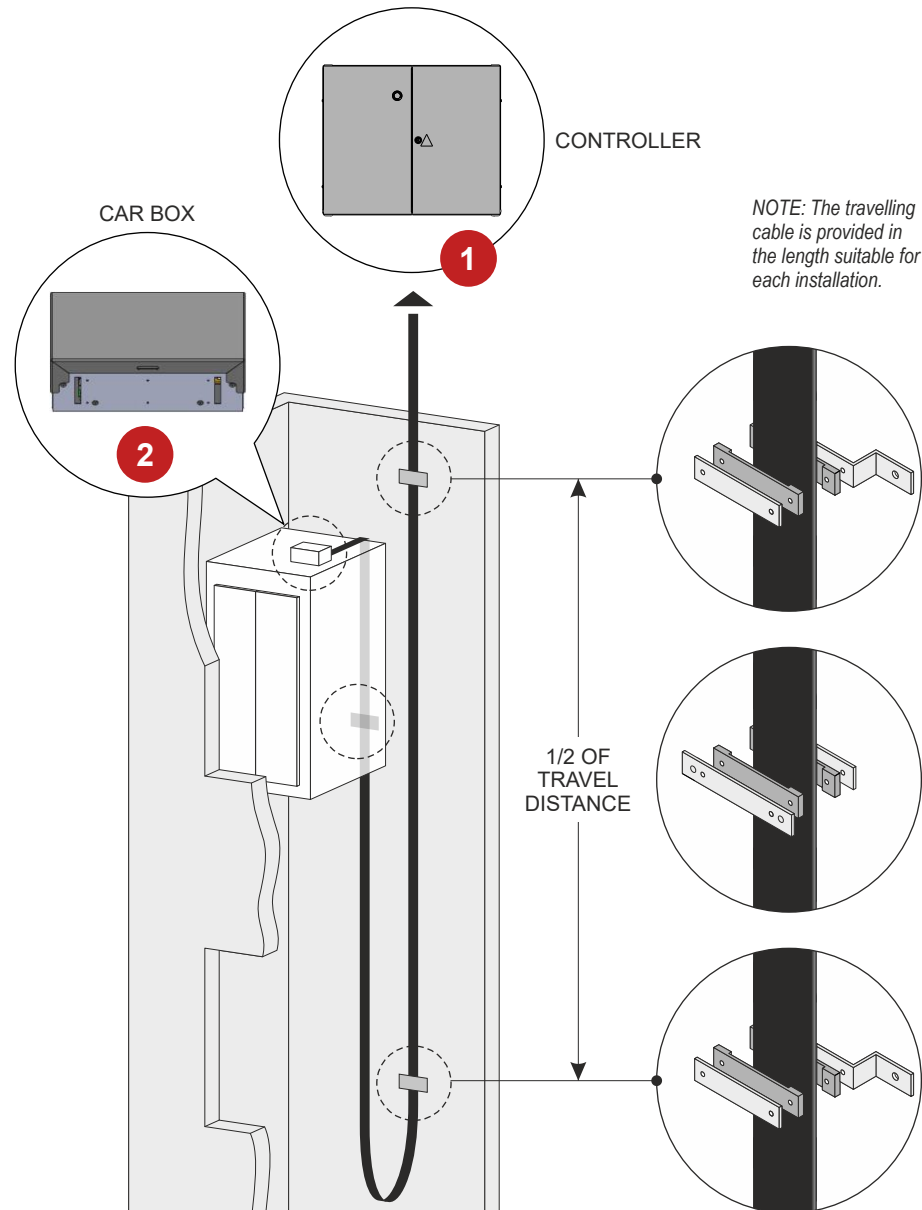

## CONNECTING THE TRAVELLING CABLE TO THE CAR DISPATCHING BOARDS

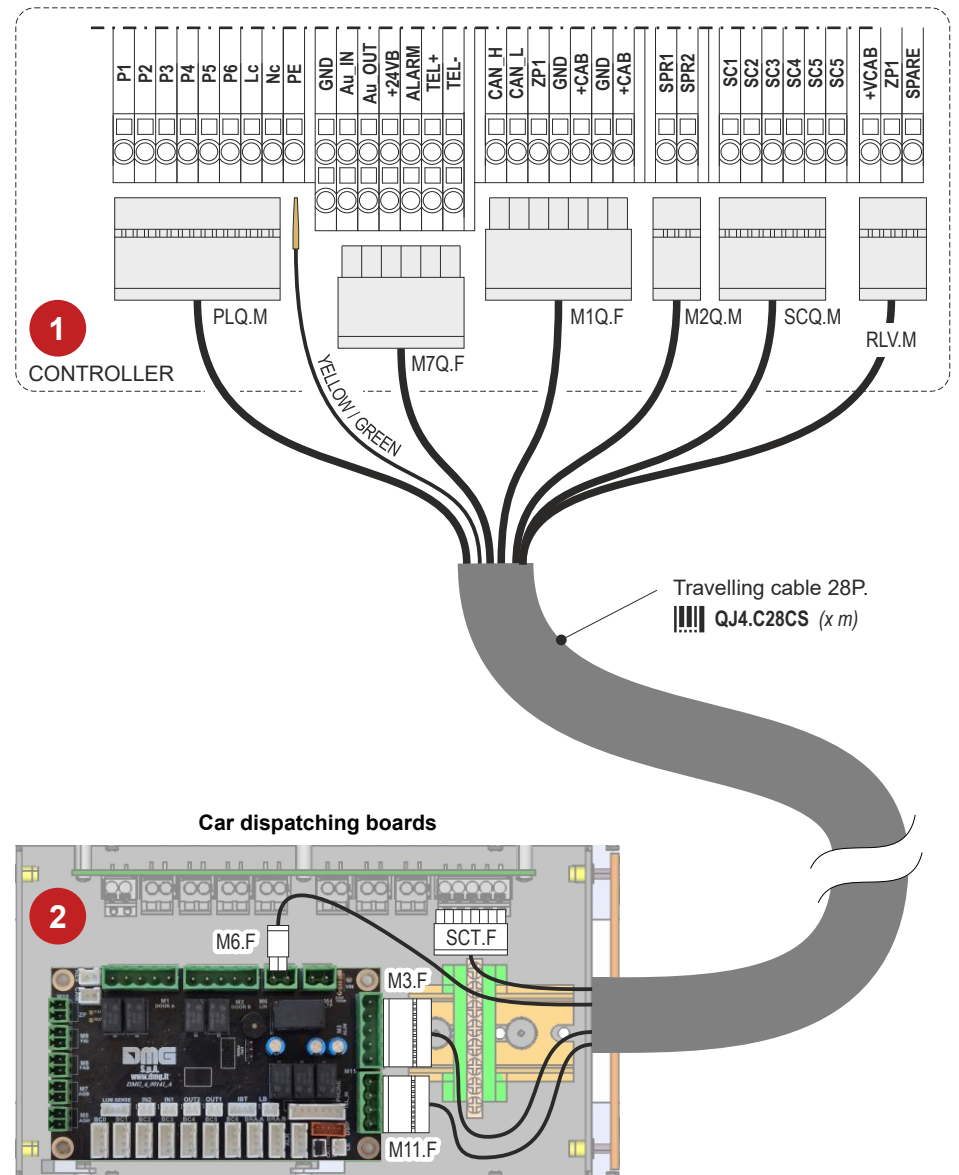

## PHASE 1 - TEMPORARY MODE & ELECTRICAL CONNECTIONS

### TEMPORARY OPERATIONS

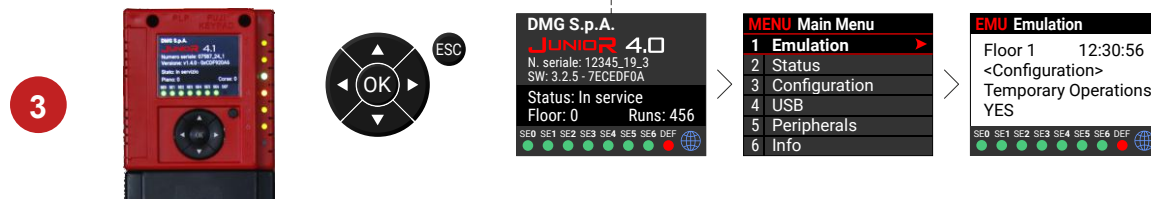
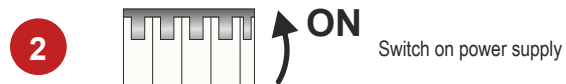
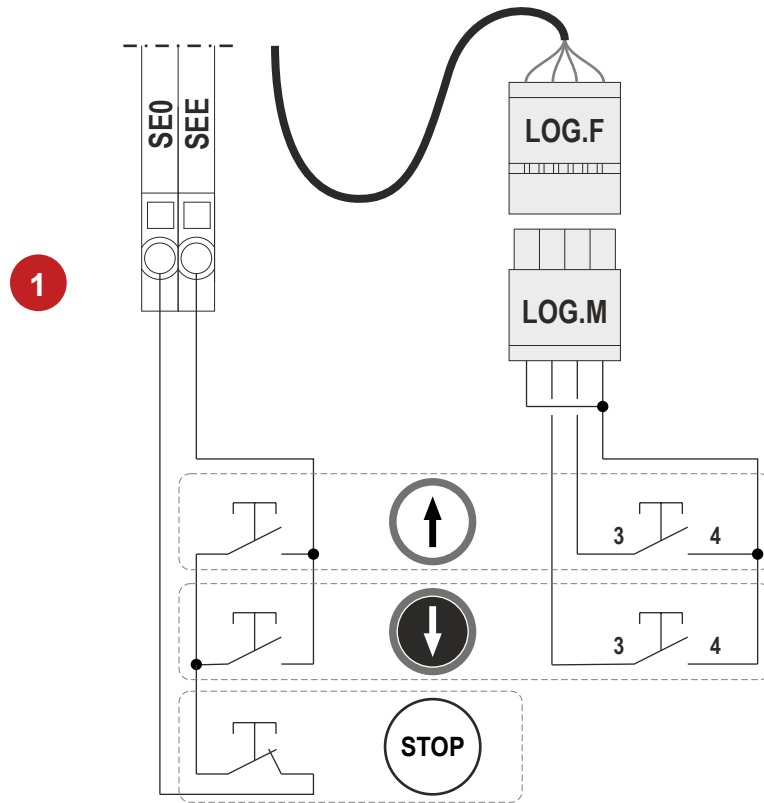

You may need to press (or hold) ESC several times to start from the menu's home screen.

# MOTOR DATA SELF-LEARNING PROCEDURE

- MRL GEARLESS motors -

1

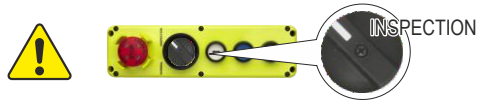

2

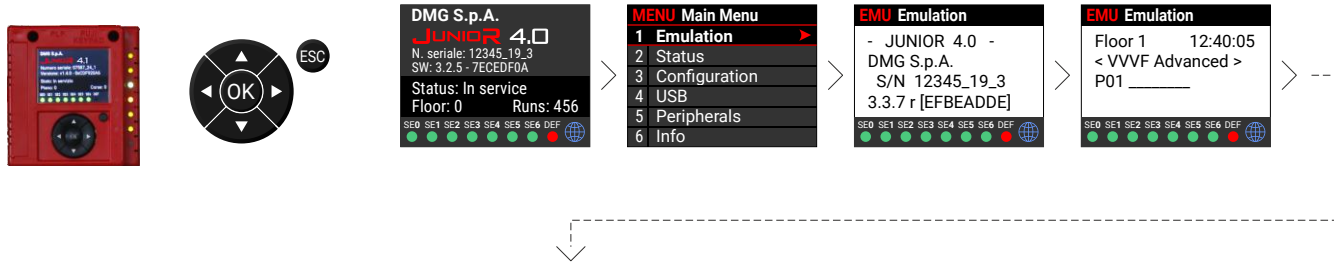

- |                       |  |
|-----------------------|--|
| VVVF Fuji             |  |
| P01 - Motor poles     | ---->> Enter the number of motor poles                             |
| F03 - Maximum speed   | ---->> Enter the maximum motor speed (RPM)                         |
| F04 - Rated Speed     | ---->> Enter the rated motor speed (Hz)                            |
| F05 - Rated Voltage   | ---->> Enter the rated motor Voltage                               |
| P03 - Motor Rated Cur | ---->> Enter the rated current intensity of the machine            |
| P02 - Motor Rated Cap | ---->> Enter the rated power of the machine                        |
| LM2 INVERTER          |  |
| C11 - High speed      | ---->> Set high speed C11 (value specified on the motor nameplate) |
| C10 - Middle speed    | ---->> Set inspection/intermediate speed C10                       |
| C07 - Creep speed     | ---->> Set low speed C07 (typically 10% of C11)                    |
| L01 - PG select       | ---->> Set the motor encoder type (ENDAT=4 ; SIN-COS=5)            |
| L02 - PG resolution   | ---->> Set the motor encoder resolution (typically 2048)           |
| L03 - P.P. Tuning     |  |

*These parameters are programmed in factory, if values are provided with the order..*

3

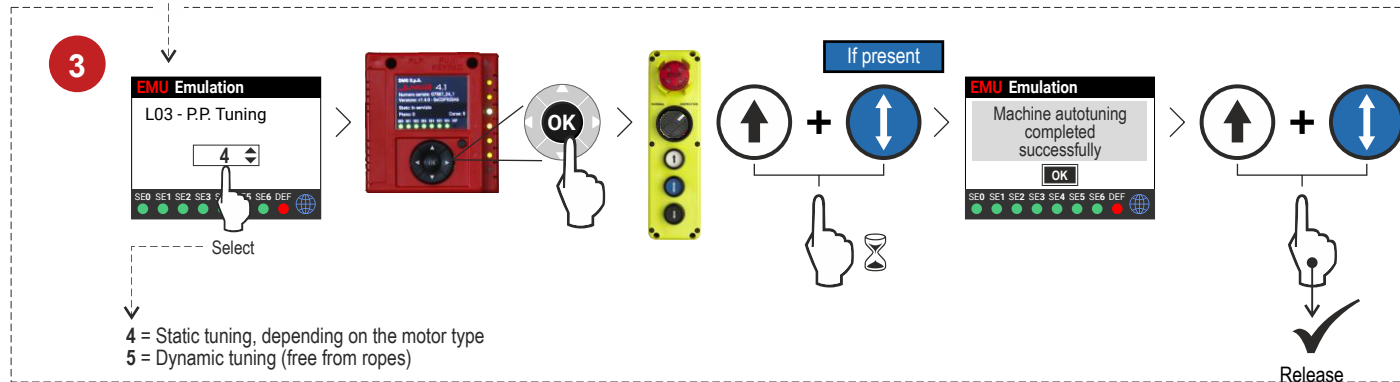

4 = Static tuning, depending on the motor type  
5 = Dynamic tuning (free from ropes)

- In case something is wrong during the procedure, the error is registered in the menu "ERRORS" (52=er7 - Error VVVF - Sub xxx). If so, refer to the troubleshooting to resolve the issue, then clear the error and repeat the procedure.  
- At the end of the procedure, press the UP/DOWN button and check the correct movement direction of the car; if not correct, invert values of parameters E98 and E99.

## INSTALLING THE SAFETY CHAIN

IN THE CAR

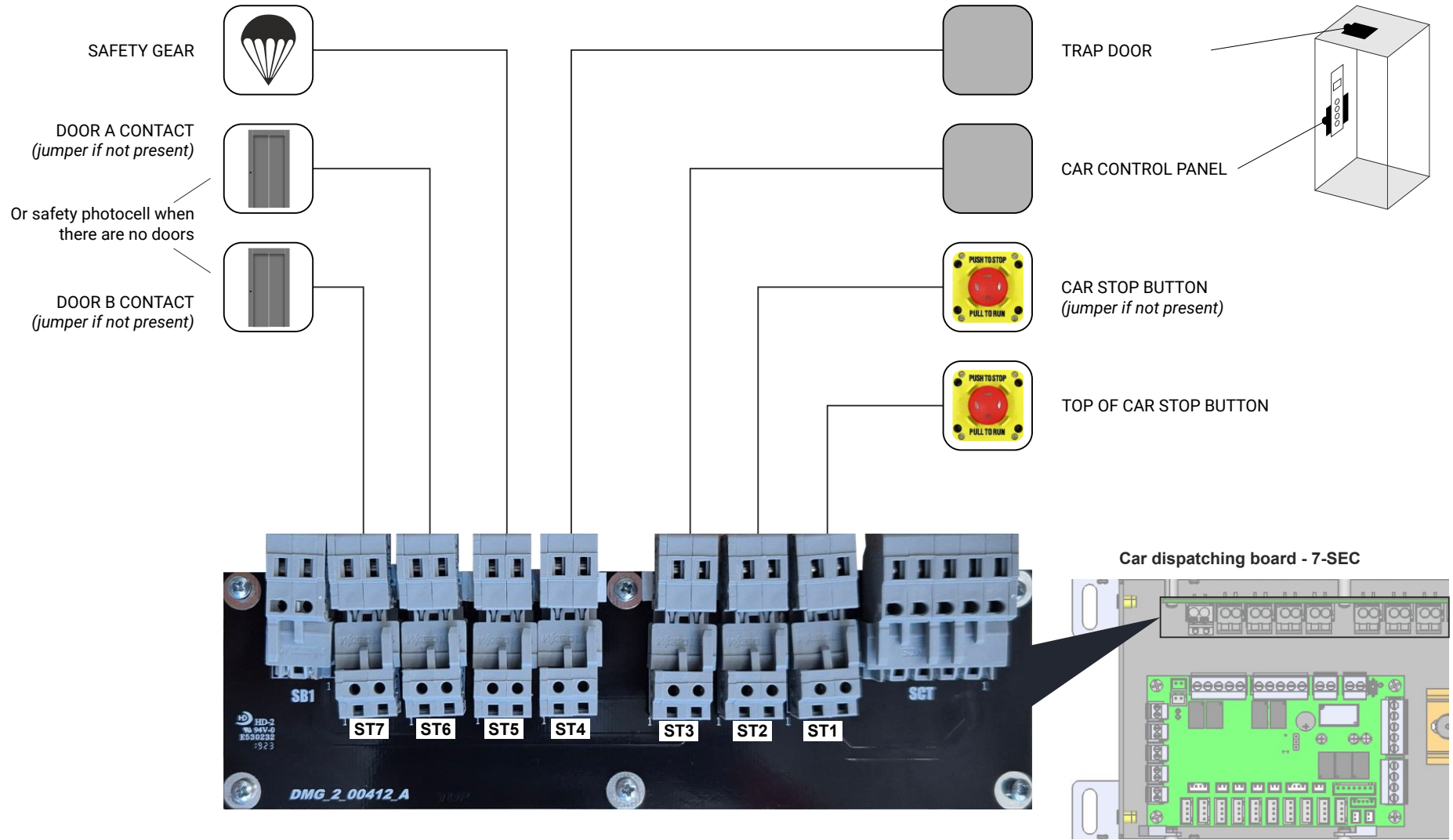

## INSTALLING THE SAFETY CHAIN (GEARLESS/GEARED WITHOUT OSG A3)

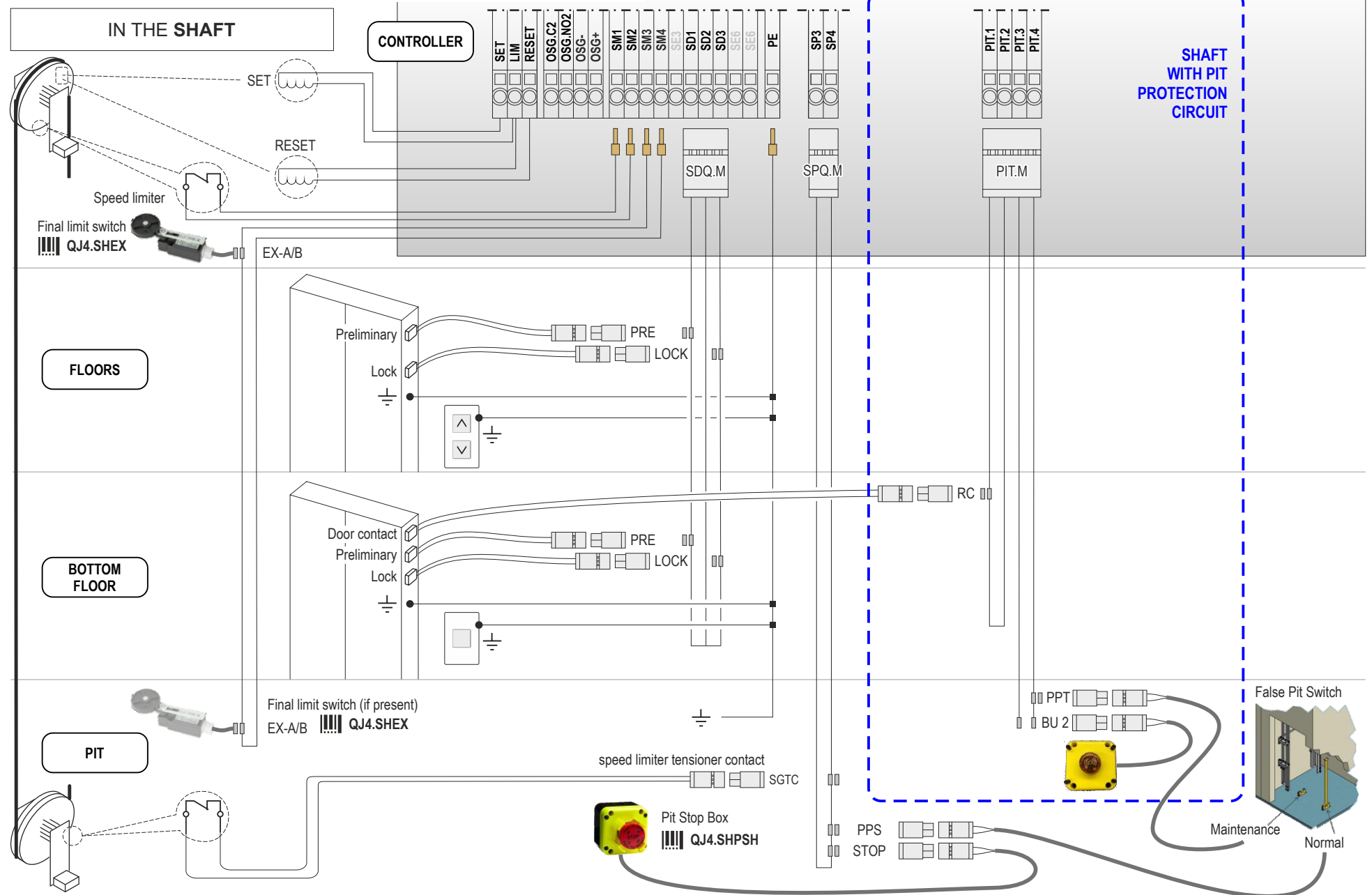

## CONNECTING CAR DOORS OPERATOR

AUTOMATIC

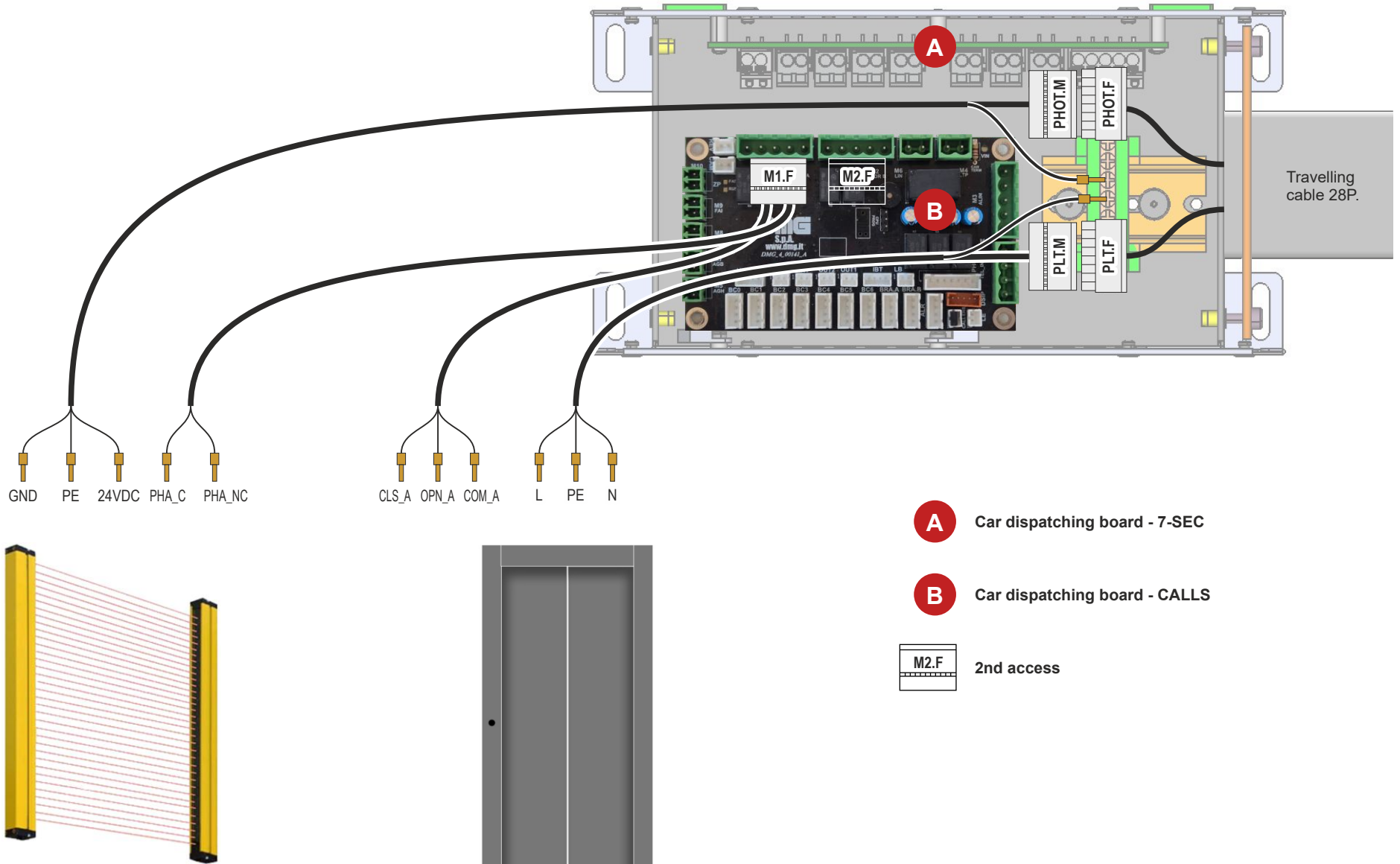

**A** Car dispatching board - 7-SEC

**B** Car dispatching board - CALLS

**M2.F** 2nd access

PRISMA AUTOMATIC

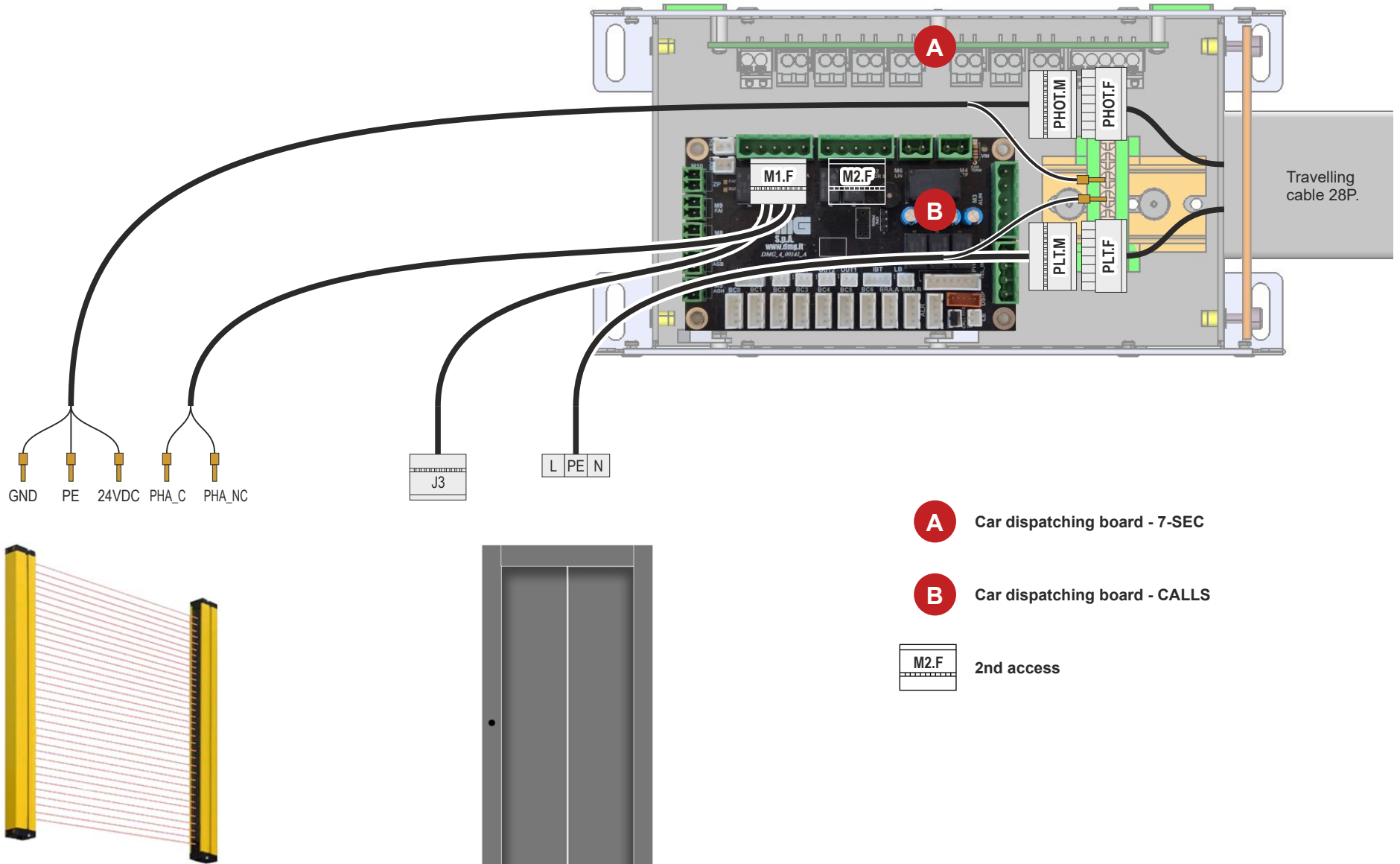

**A** Car dispatching board - 7-SEC

**B** Car dispatching board - CALLS

**M2.F** 2nd access

FERMATOR DC+ 24V AUTOMATIC

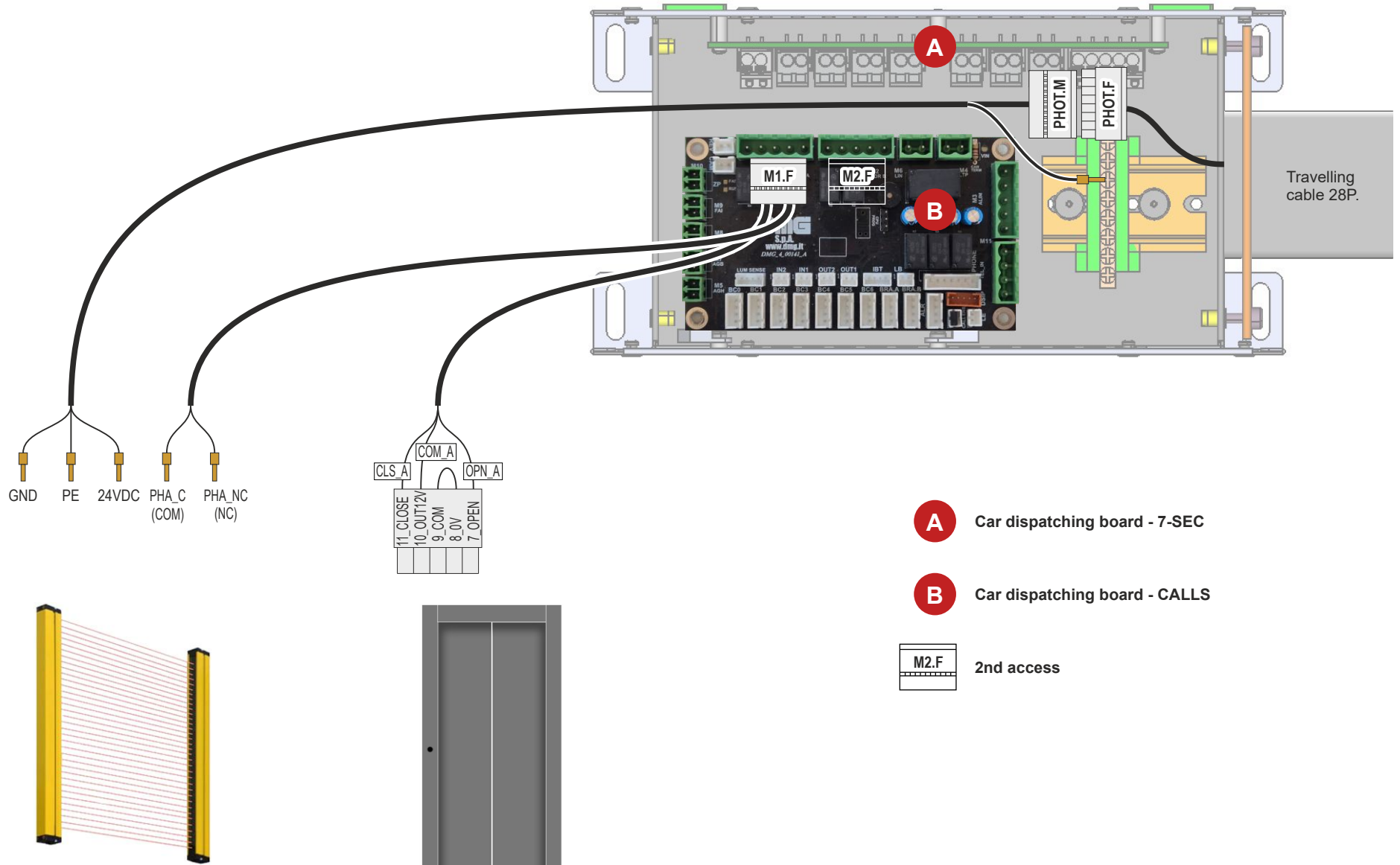

FERMATOR VF5+ AUTOMATIC

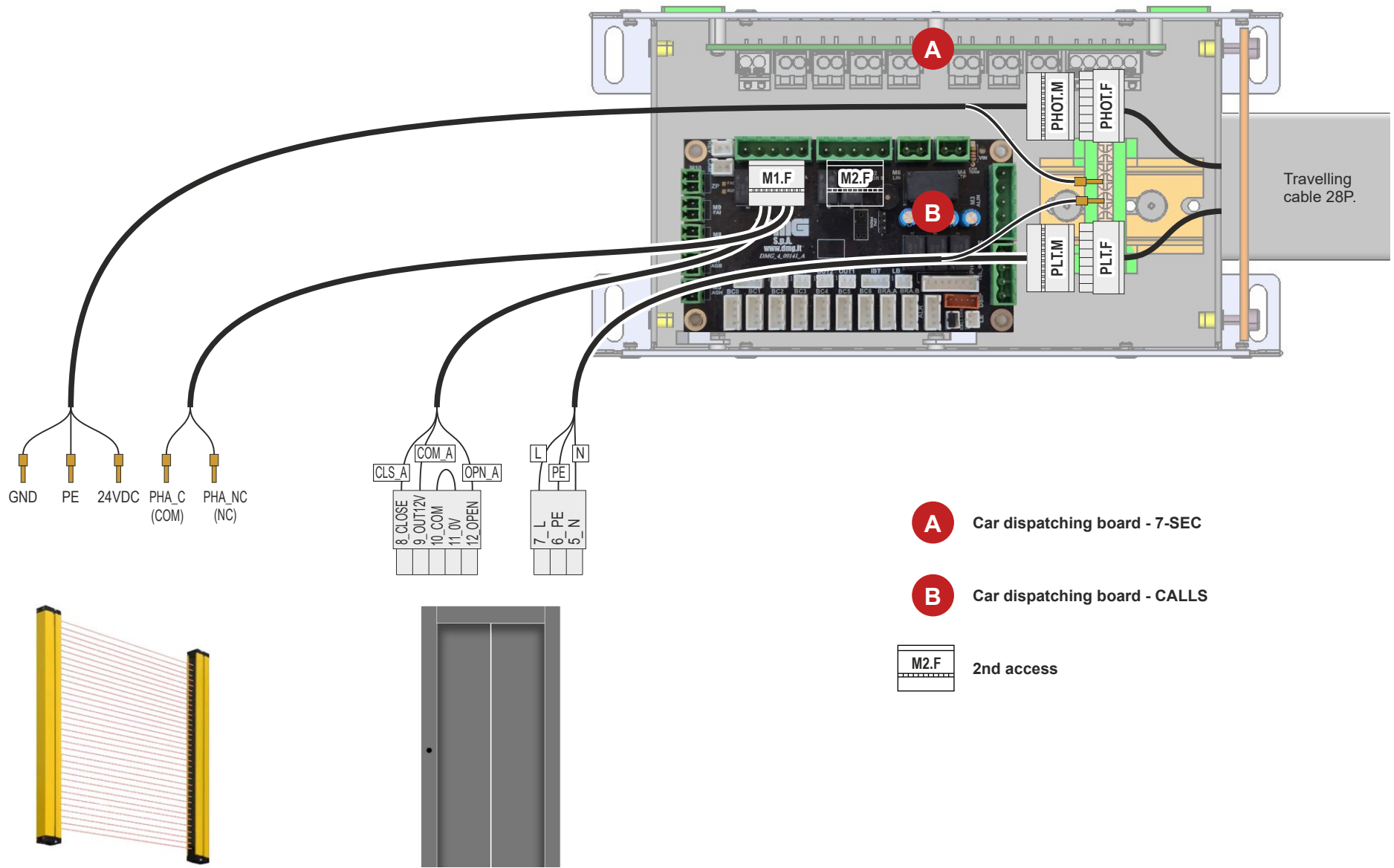

## CONNECTING LIGHT BARRIERS (NO CAR DOORS)

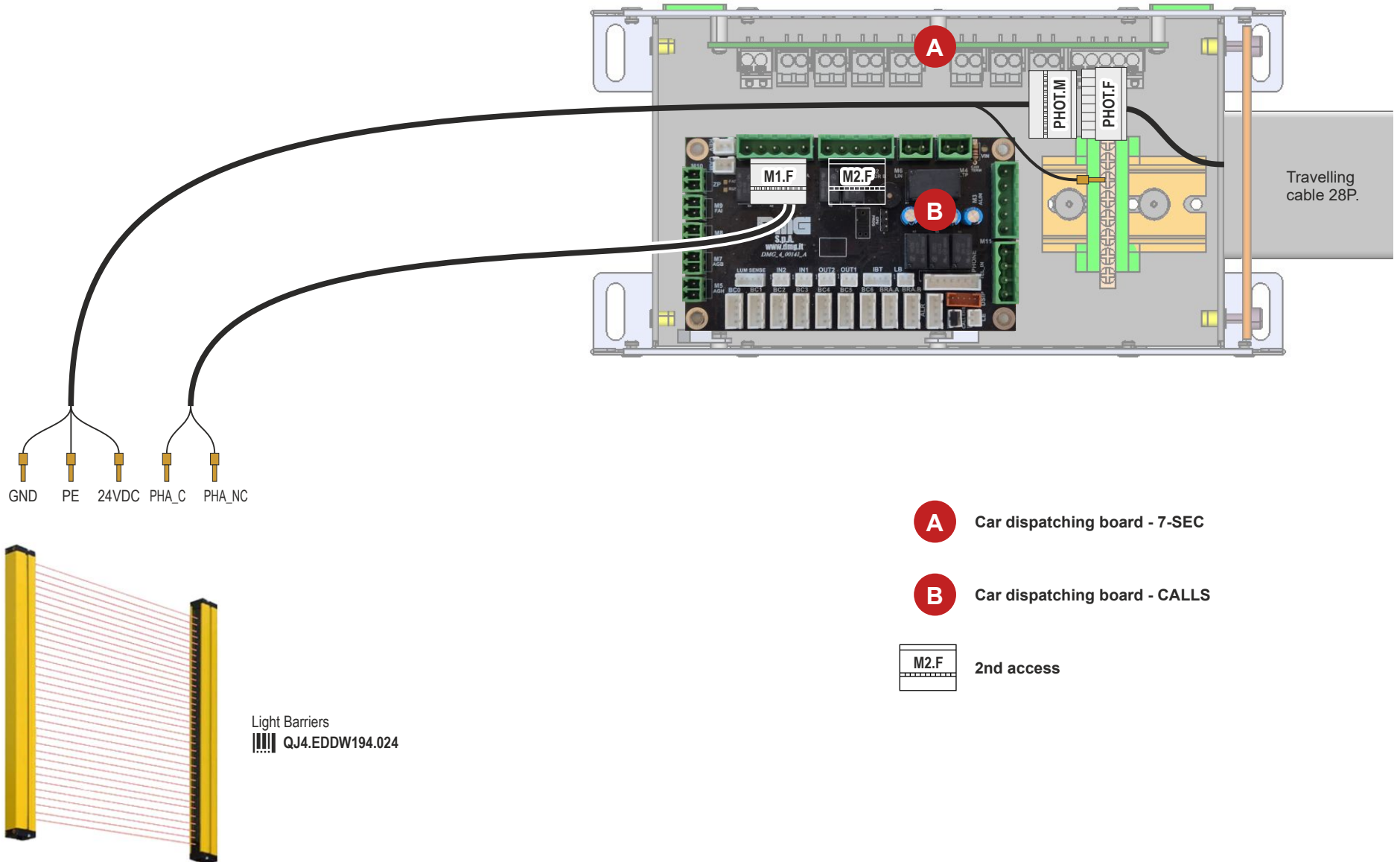

# CAR POSITION READING SYSTEM

## 1 REFERENCE LAYOUT FOR MAGNETS AND MAGNETIC READERS

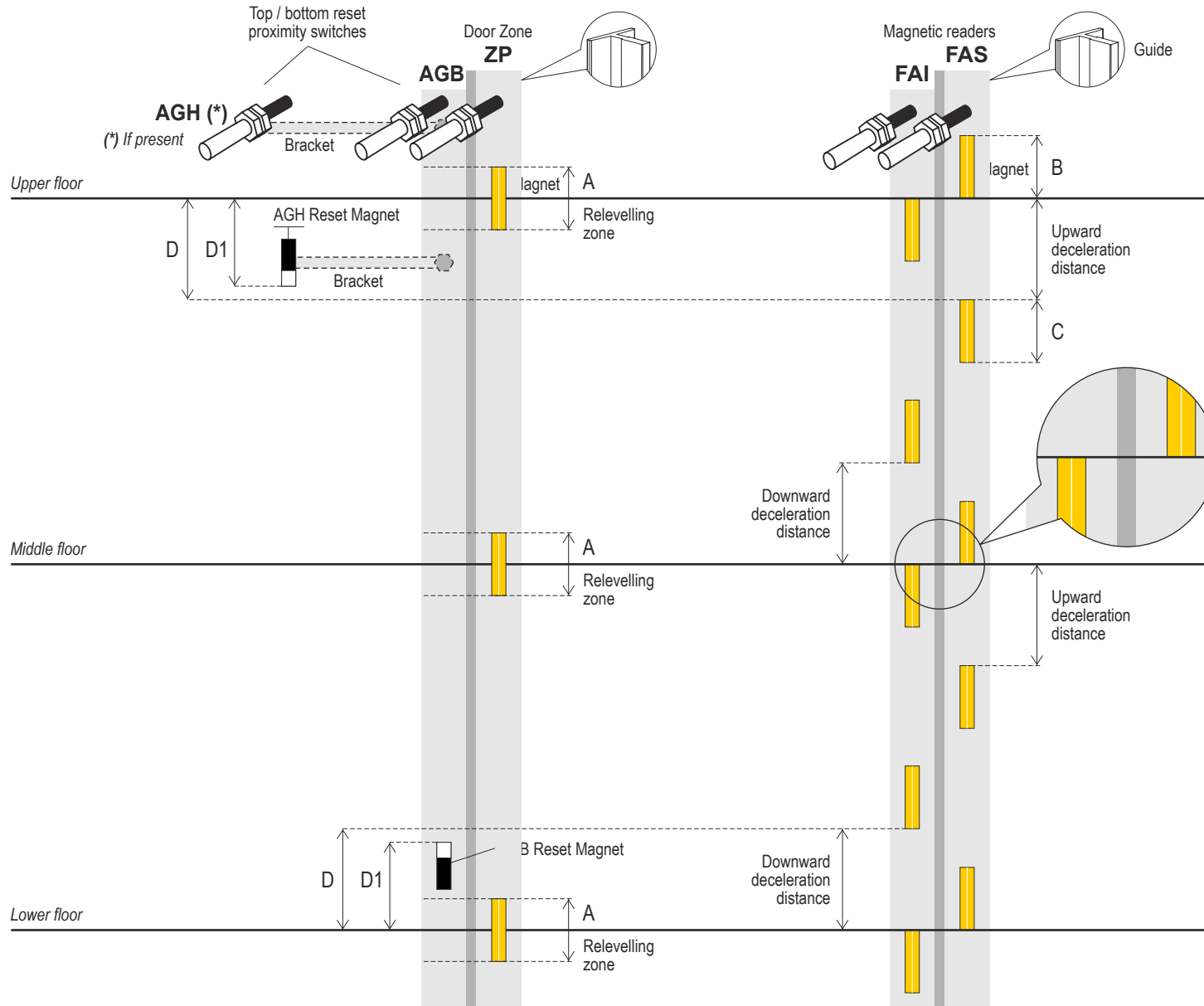

The deceleration magnets (C) can be shortened if necessary.

| Lengths (mm) | Lengths (with fixed retiring cam) |  |
|--------------|-----------------------------------|--|
| A = 100      | A = 100                           |  |
| B = 100      | B = 100                           |  |
| C = 100      | C = 100                           |  |

| Speed (m/s) | D (mm) | D1 (mm) |
|-------------|--------|---------|
| 0,15        | 250    | D-20    |
| 0,30        | 400    | D-20    |

### Installation KIT

#### QJ4.CTKIMP.H5

##### Magnetic Readers

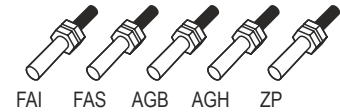

##### Reset Magnets



#### QJ4.CTKIMP.H4

##### Magnetic Readers

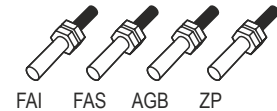

##### Reset Magnets



#### QJ4.SHCAL100

##### 1 Magnet



#### QJ4.SHSAFCR

##### 1 Bracket (optional)

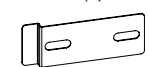

#### QJ4.KSHCAL

(in case of retiring ramp)

4 x 150

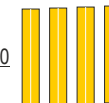

1 x 200

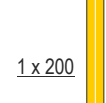

## 2 INSTALLING MAGNETS AND MAGNETIC READERS

### MAGNETIC READERS POSITIONING SYSTEM

#### FAI / FAS

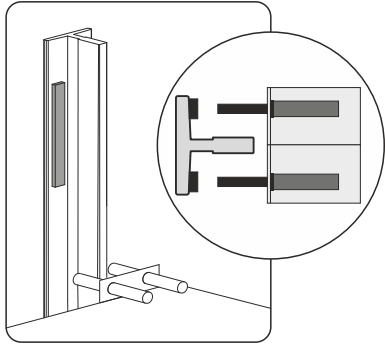

||||| QJ4.CTKIMP.H5 or ||||| QJ4.CTKIMP.H4

+

||||| QJ4.SHCAL100

4 magnets for the middle floors  
2 magnets for the upper floor  
2 magnets for the lower floor  
or

||||| QJ4.KSHCAL (in case of fixed ritiring ramp)  
4 magnets 150mm for each floors

### TOP / BOTTOM RESET PROXIMITY SWITCHES

#### AGB / AGH

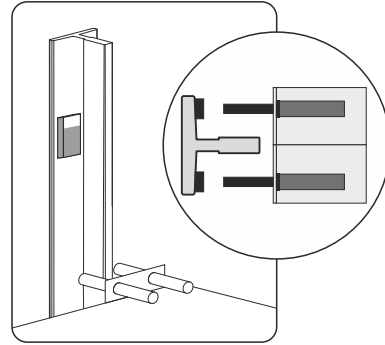

||||| QJ4.CTKIMP.H5

### BOTTOM RESET PROXIMITY SWITCH

#### AGB

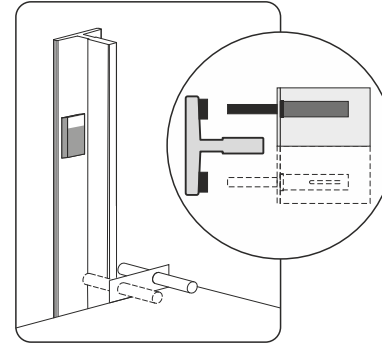

||||| QJ4.CTKIMP.H4

### DOOR ZONE / RELEVELLING

#### ZP

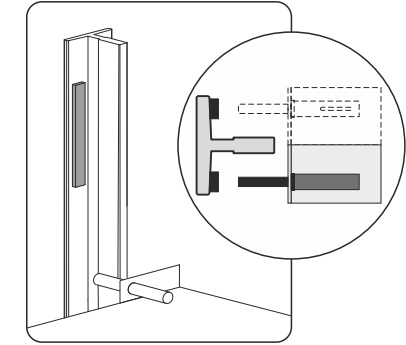

||||| QJ4.CTKIMP.H5 or ||||| QJ4.CTKIMP.H4

+

||||| QJ4.SHCAL100

1 magnet for each floors

or

||||| QJ4.KSHCAL (in case of fixed ritiring ramp)  
1 magnet 200mm for each floors

## 3 CONNECTING THE MAGNETIC READERS

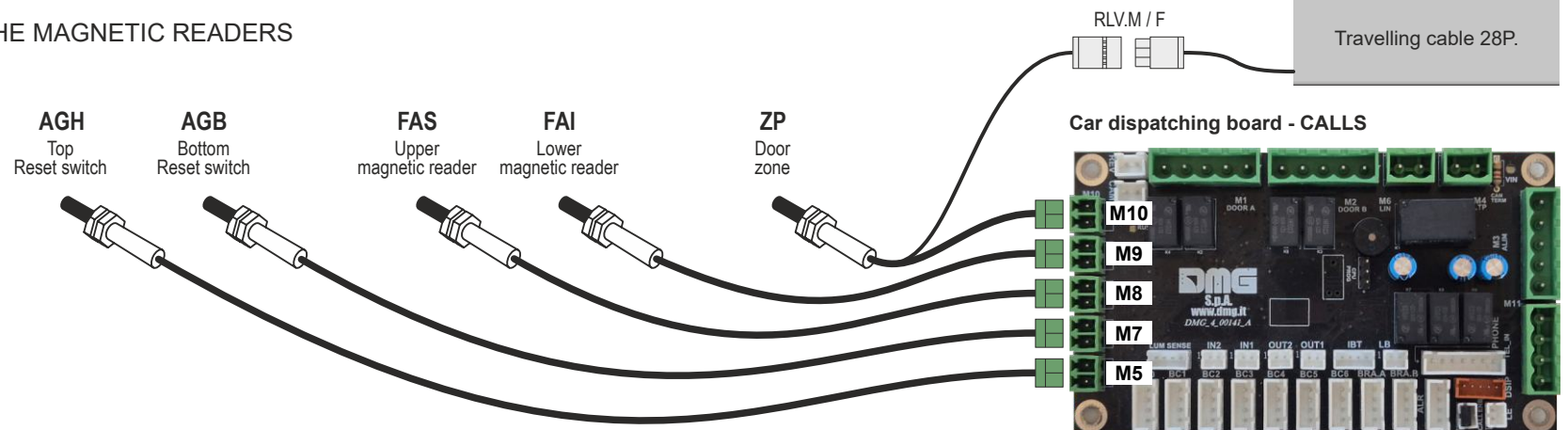

# CONNECTING THE CAR ILLUMINATION

12V DC

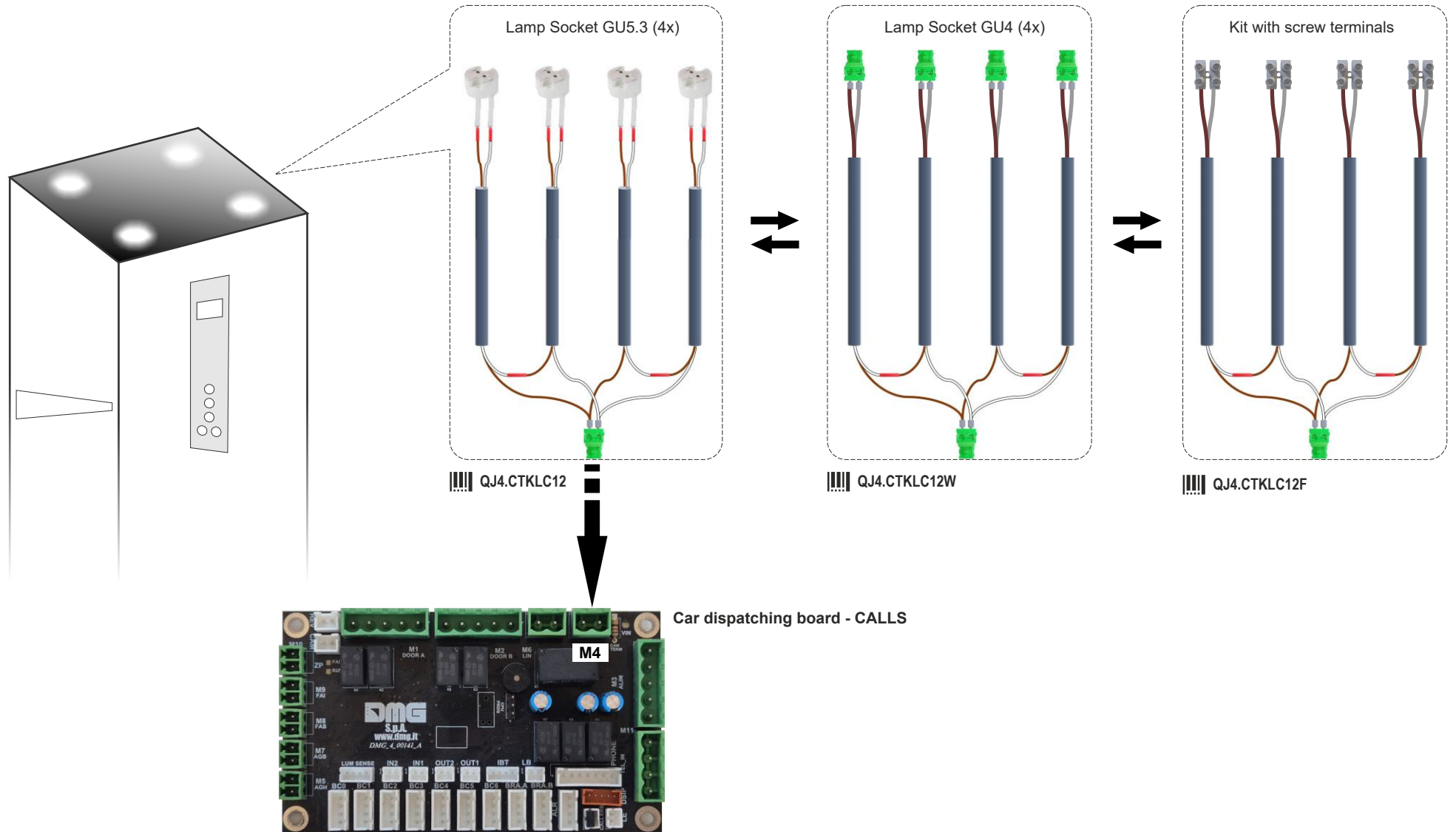

24V DC

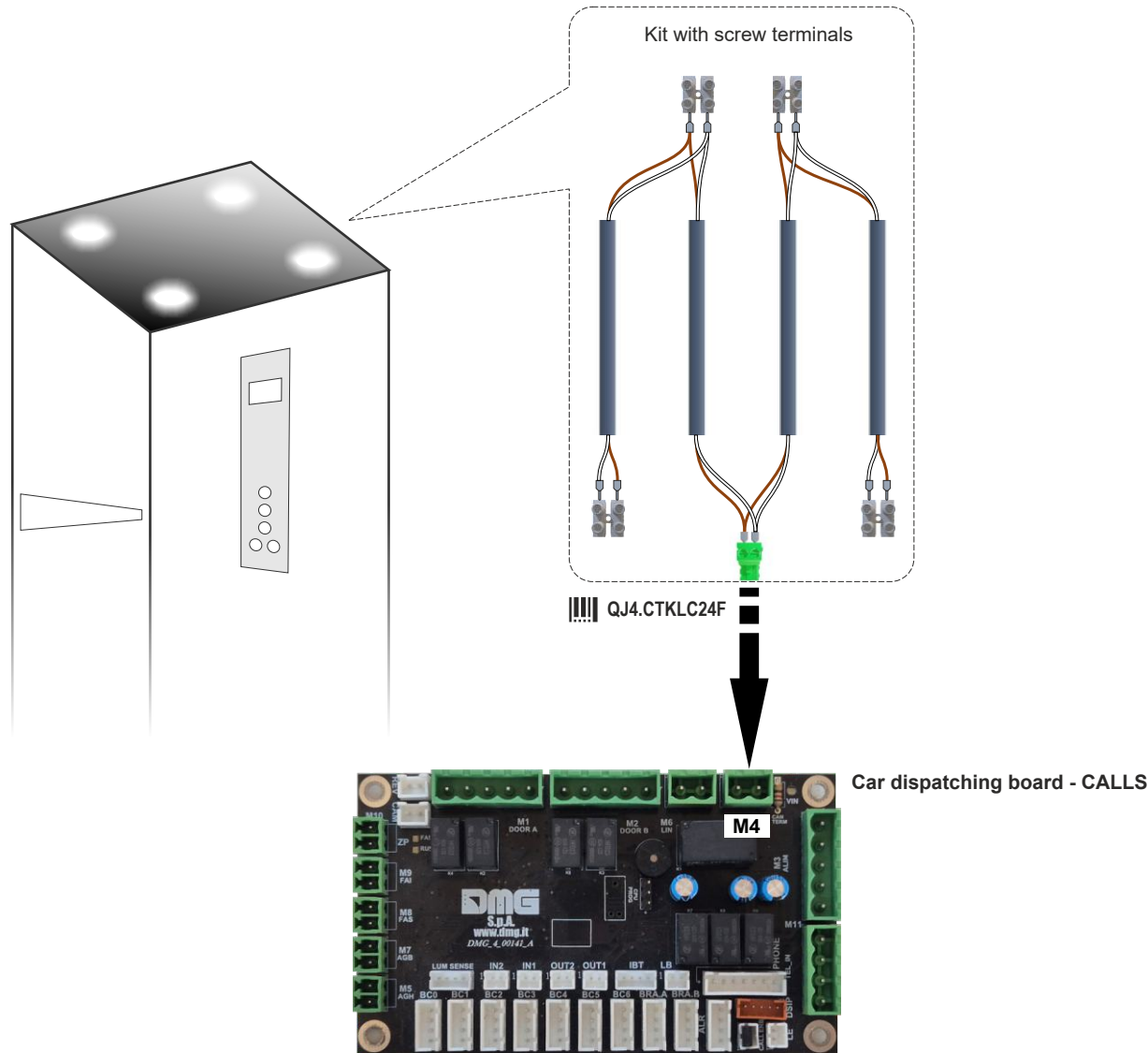

230V AC

The positioning of this module is at installer's discretion

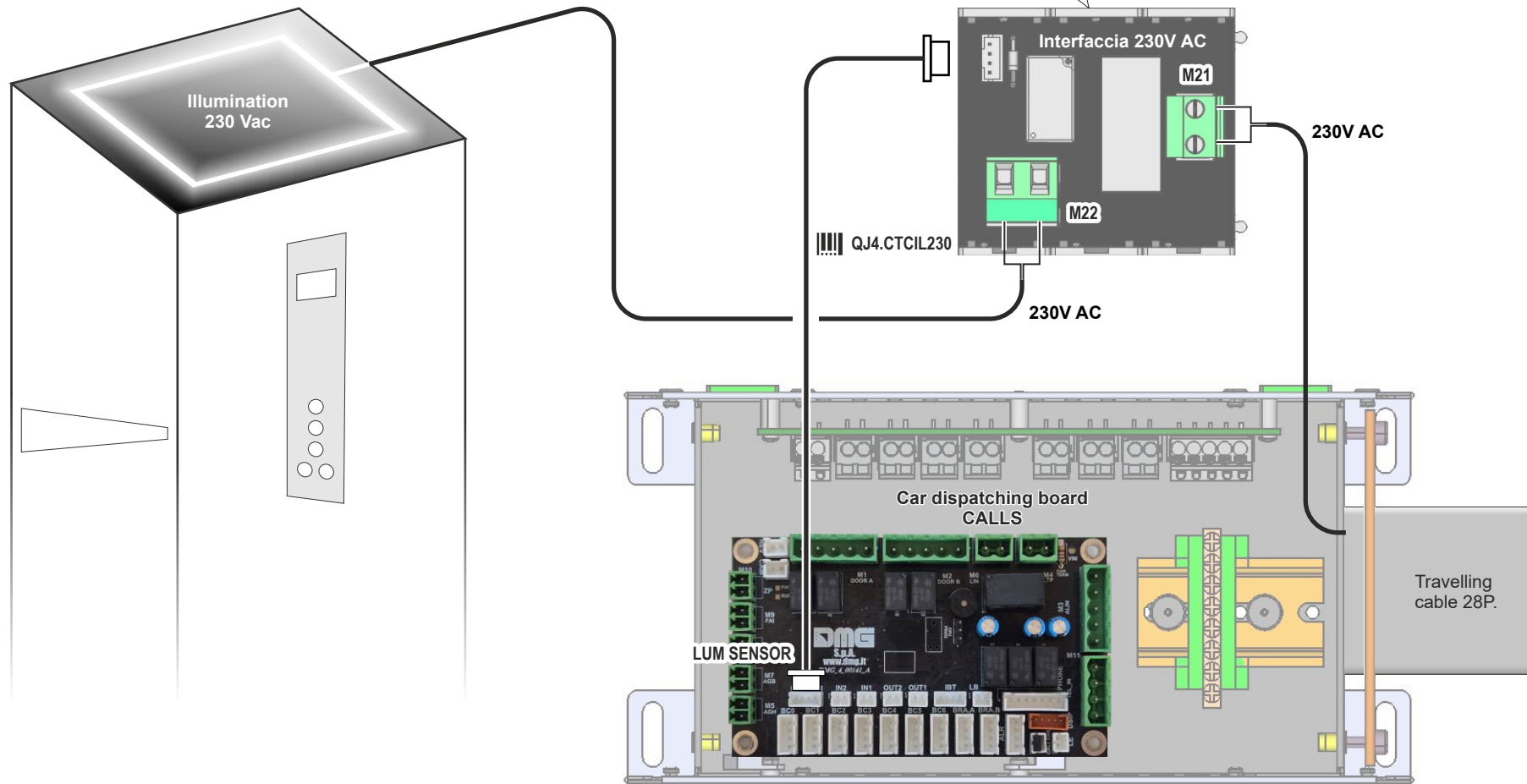

## CONNECTING THE INSPECTION BOX

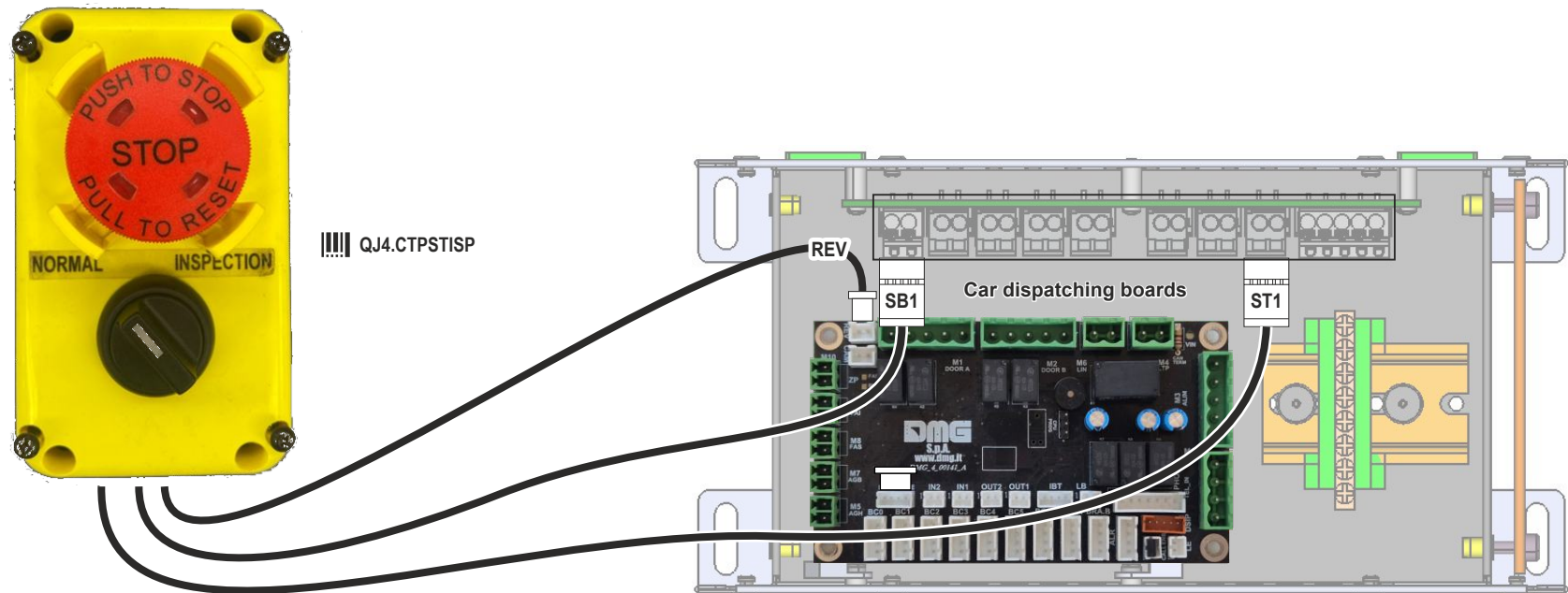
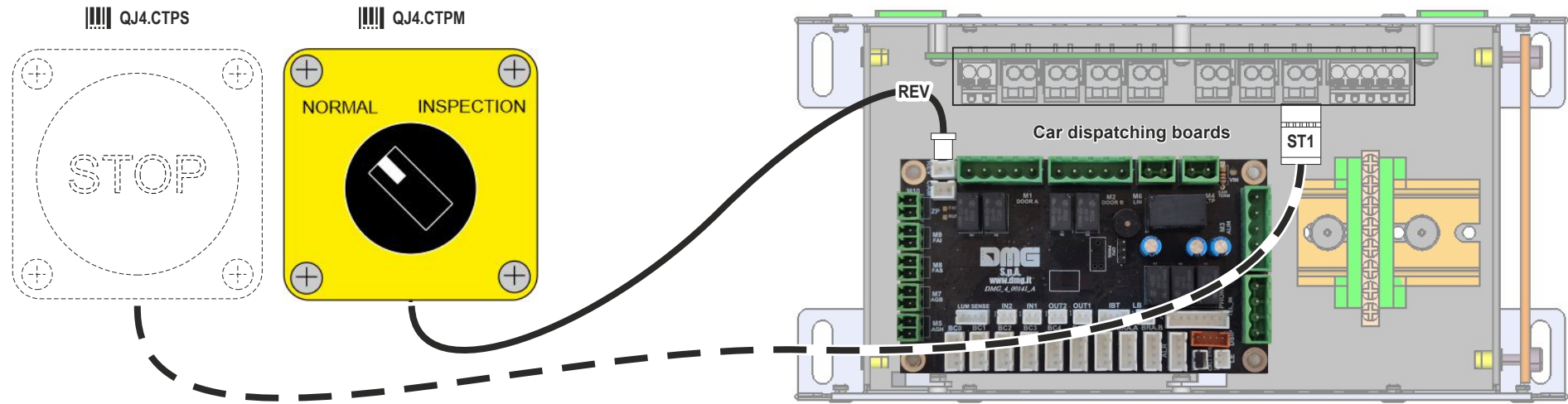

## INSTALLING THE CAR PANEL

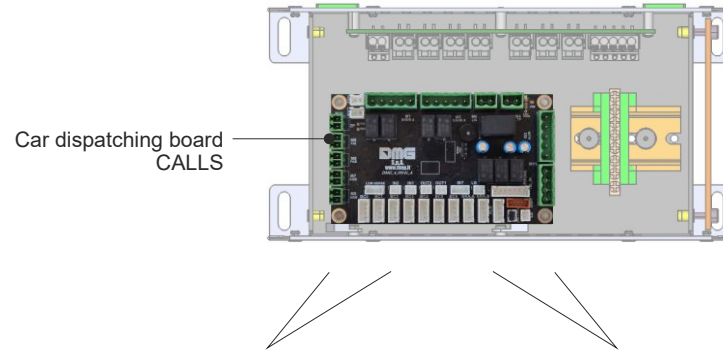

### DISPLAY & INDICATORS

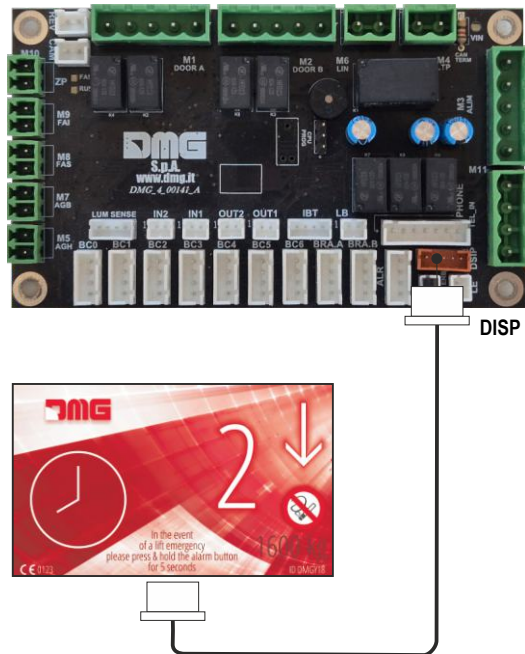

### CALL / SERVICE BUTTONS

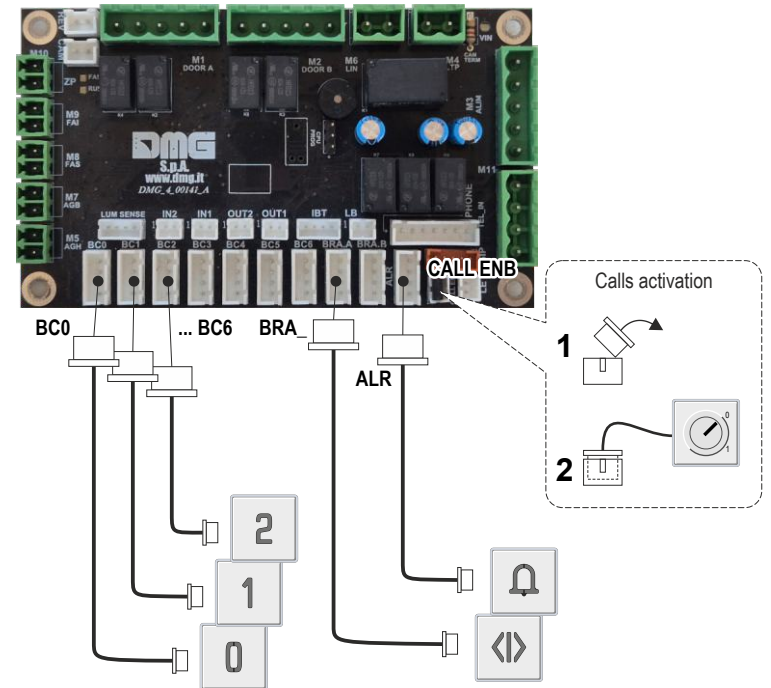

## INSTALLING THE FLOOR PANELS

Floor serial interface (BDU)

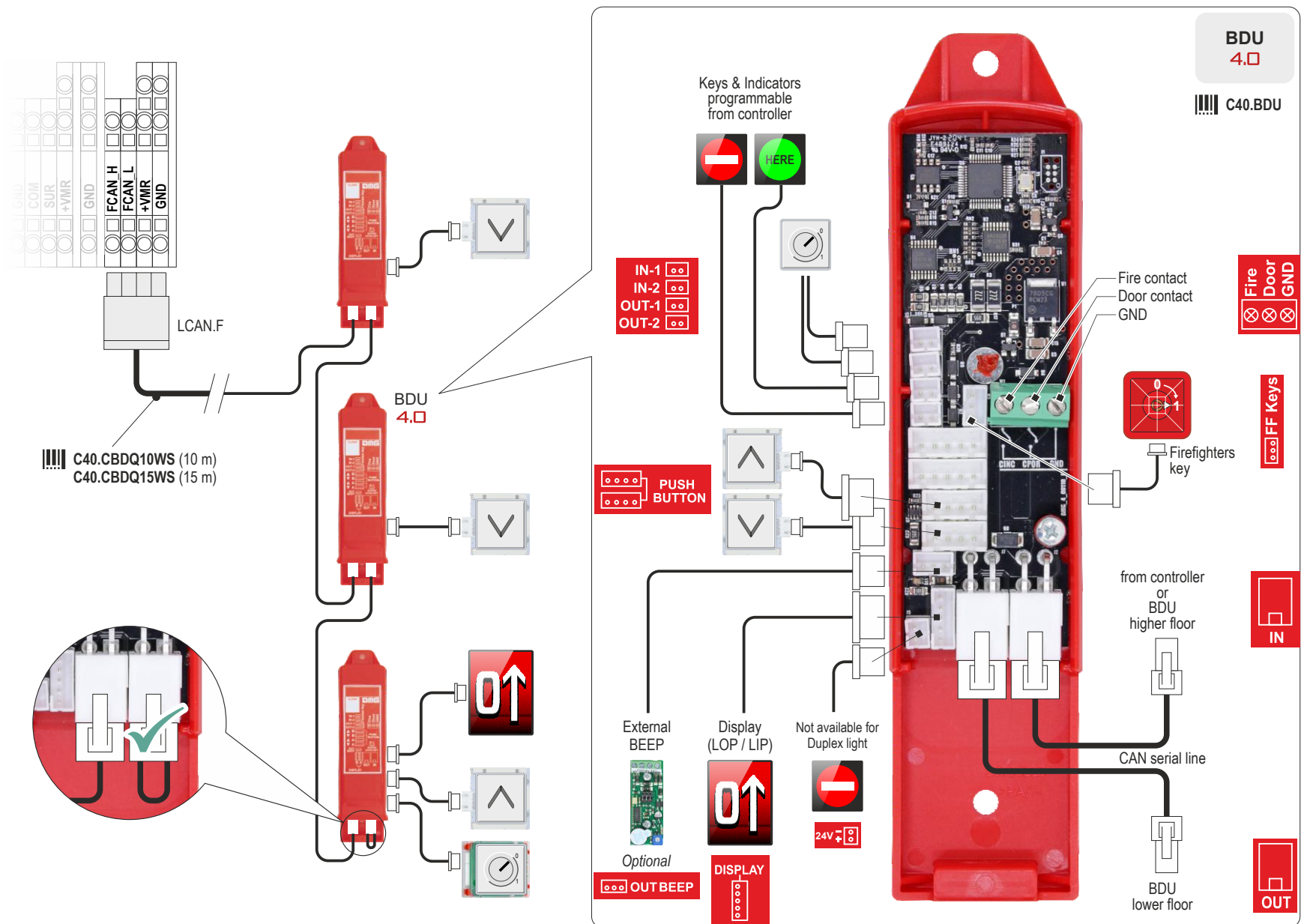

## BDU PROGRAMMING

### INPUTS

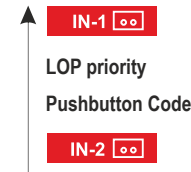
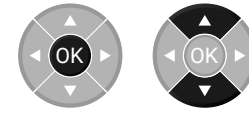
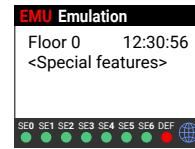
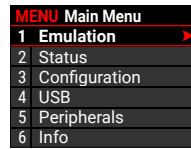
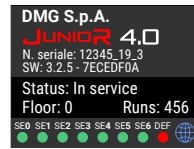

#### Default settings

**IN-1 - Call disabling** (active input closed).

**IN-2 - Key input out of service** - The system does not accept new calls, cancels the calls at the floors, and completes the calls already registered in the car, then parks at the programmed floor (Menu <Special features> - Out of service floor) standing with doors closed.

LOP priority  
Pushbutton Code  
**Baggage** (if the parameter <Signals> - Ship Functions of the controller is active)

### OUTPUTS

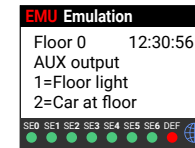
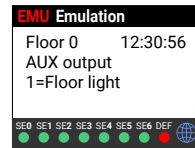
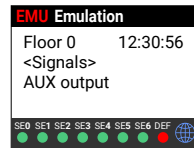
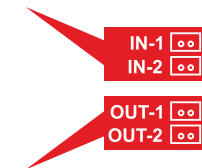
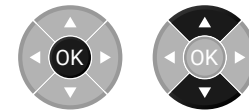
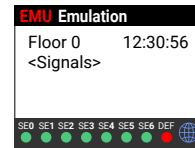
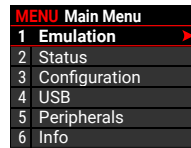
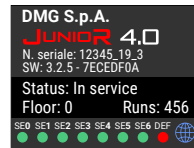

Do not modify

Do not modify

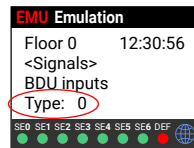

|        | OUT 1 | OUT 2           |
|--------|-------|-----------------|
| Type 0 | HERE  | NO              |
| Type 1 | ▲     | ▼               |
| Type 2 | HERE  | COMING          |
| Type 3 | HERE  | 3 wires display |

choose a setting for each floor

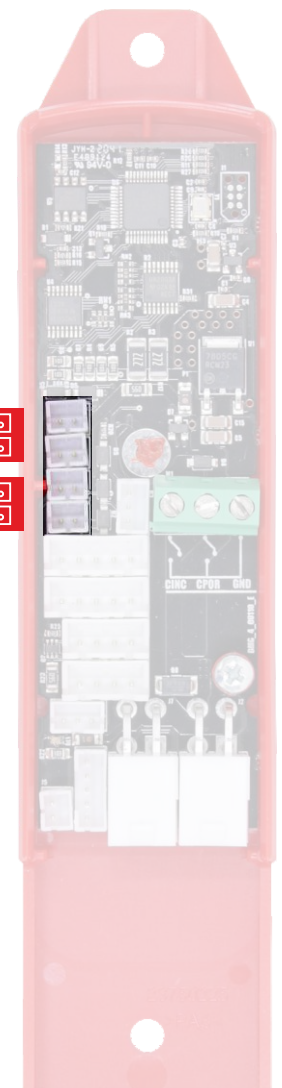
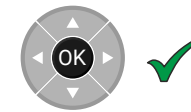

### BDU ADDRESSING

The BDUs are pre-addressed at the factory; if they are not (e.g.: after replacement), the floor call button will start flashing. To address them, follow the BDU addressing procedure described on the DIDO page.

<https://dido.dmg.it/knowledge-base/pitagora-floor-connections/>

## INSTALLING THE EMERGENCY PHONE

DMG AMIGO EMERGENCY PHONE

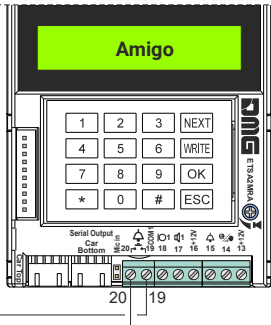
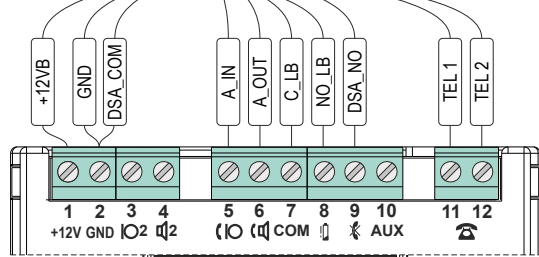
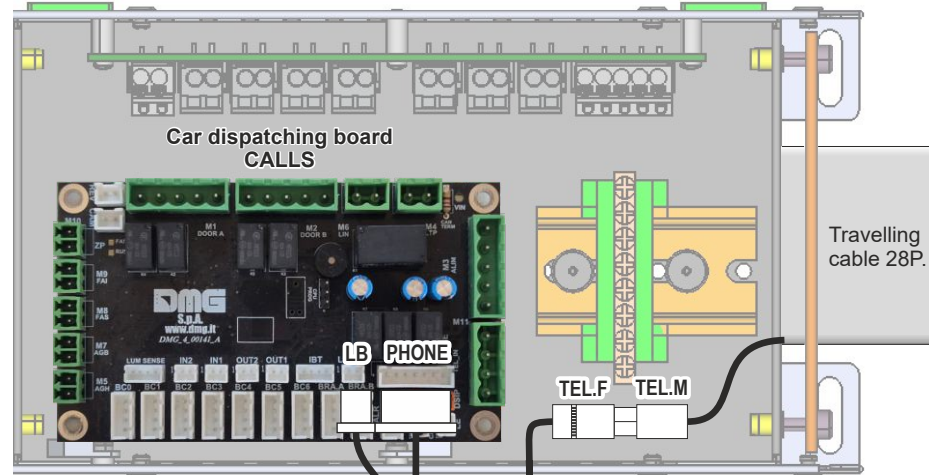

AMIGO Emergency Phone

3rd-PARTY EMERGENCY PHONE

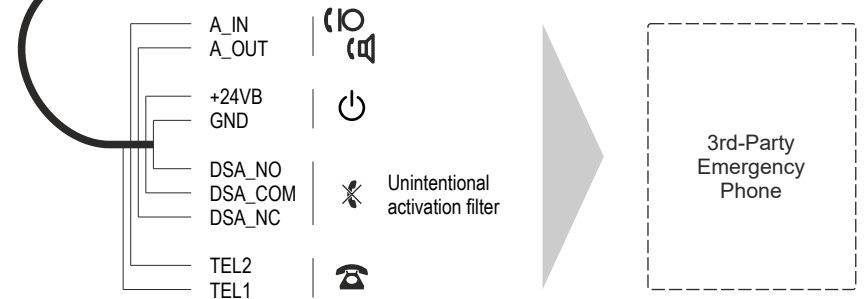
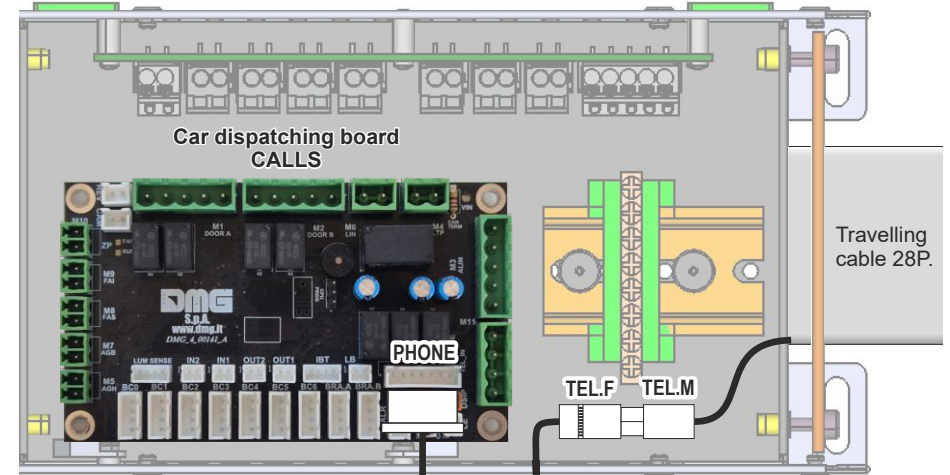

# INSTALLING THE LLEC7 LIFT LOAD ELECTRONIC CONTROL DEVICE

**DMG LLEC7 LIFT LOAD ELECTRONIC CONTROL**

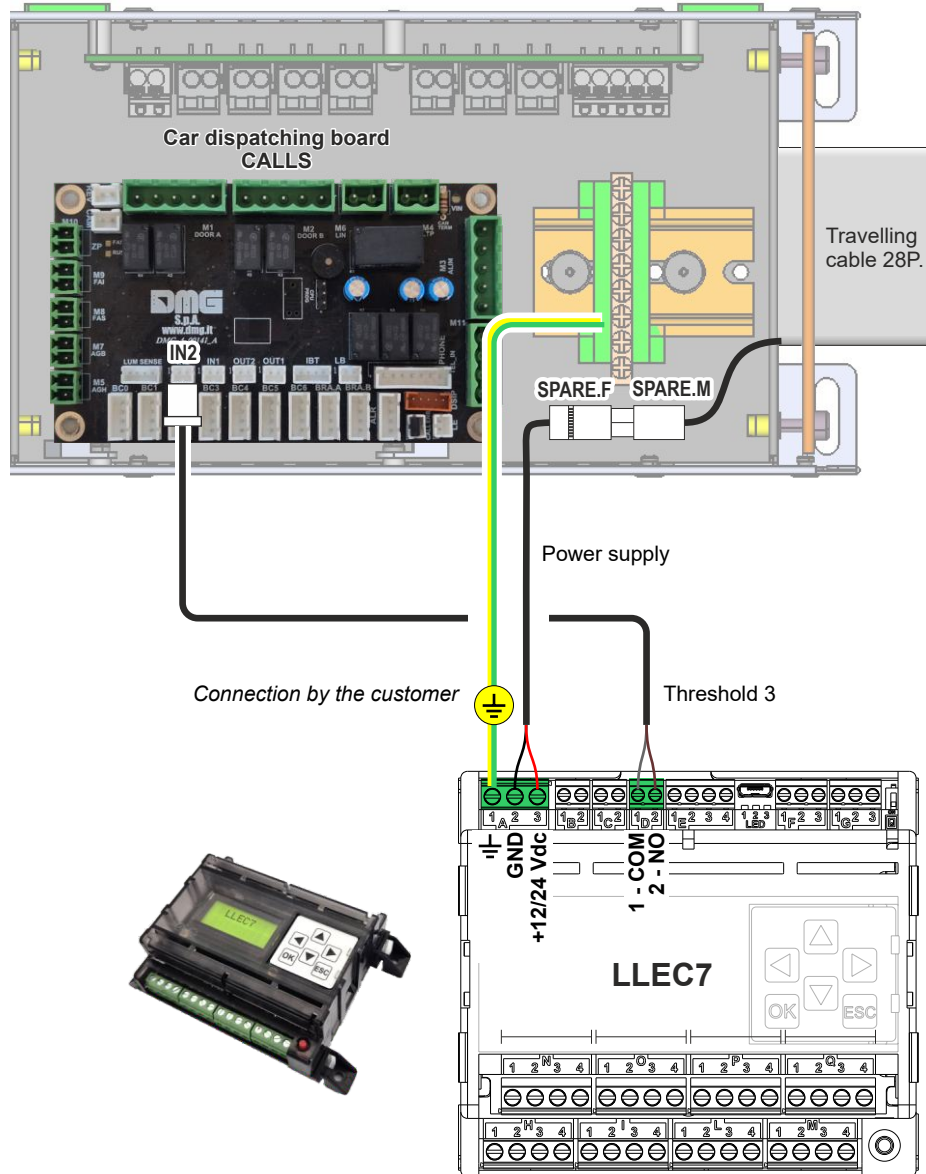

**3rd-PARTY LIFT LOAD ELECTRONIC CONTROL**

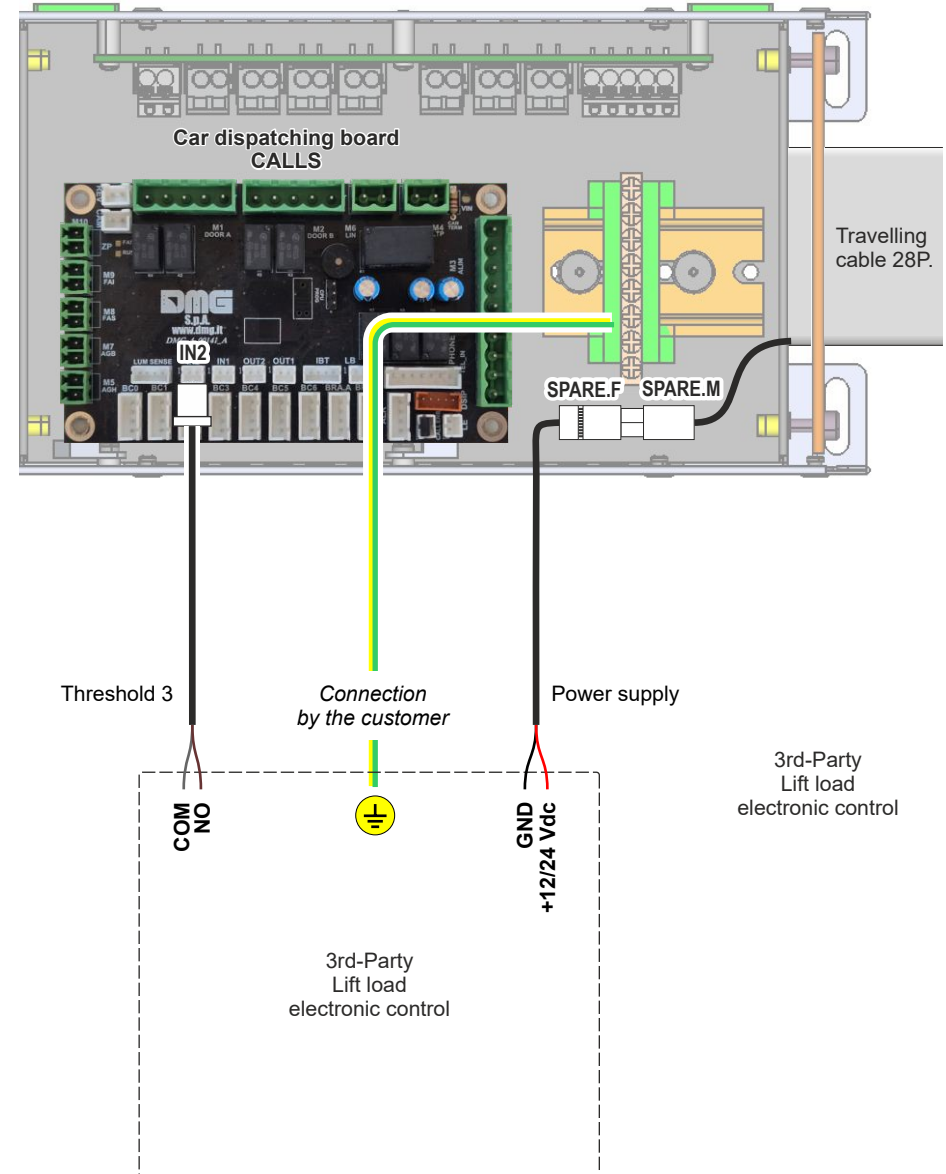

## PHASE 2 - NORMAL MODE & SYSTEM ADJUSTMENTS

### SWITCH TO NORMAL SERVICE MODE

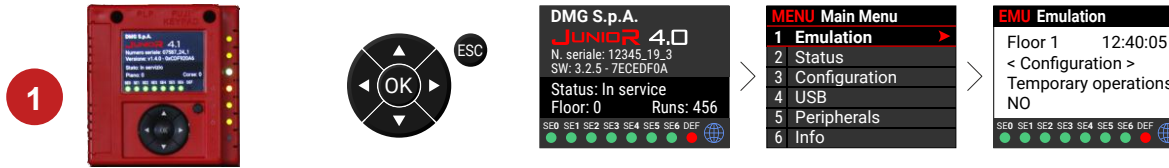

**2** Disconnect the temporary operations box

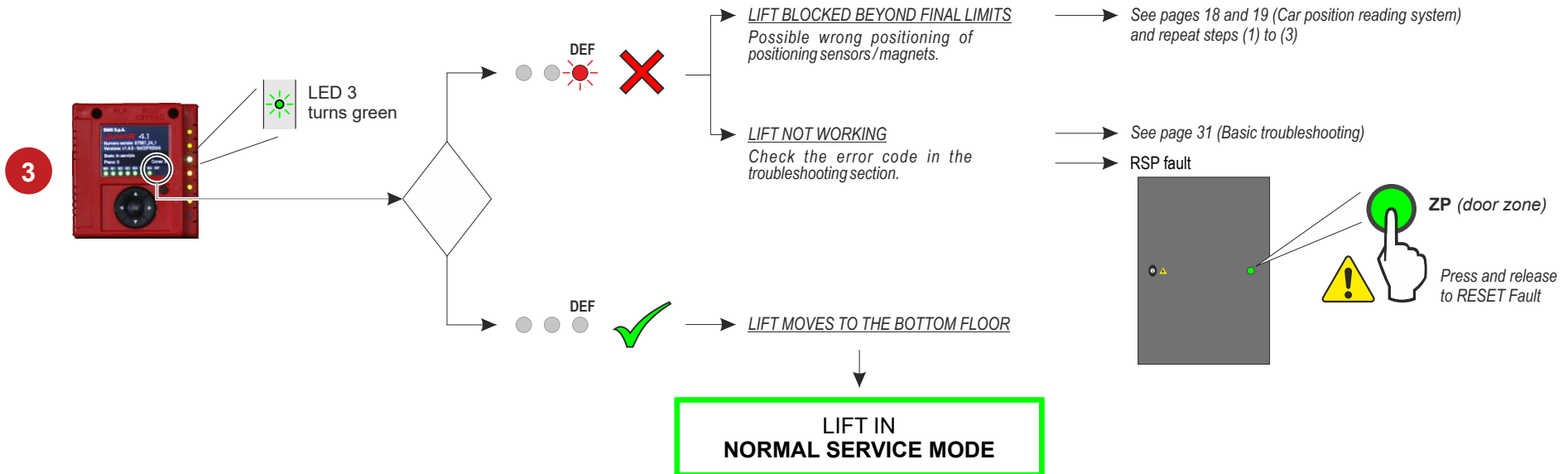

**4** Set the stopping accuracy (Fine tuning) at each floor  
See next page

**5** Perform final system test  
(check all lift functions)

## ADJUSTING FLOOR STOPPING ACCURACY

- 1 Read the gap between floor level and car floor edge.
- 2 Move **P** magnets in the shaft to adjust the stopping position.
- 3 Move **D** magnets to adjust the deceleration distance.

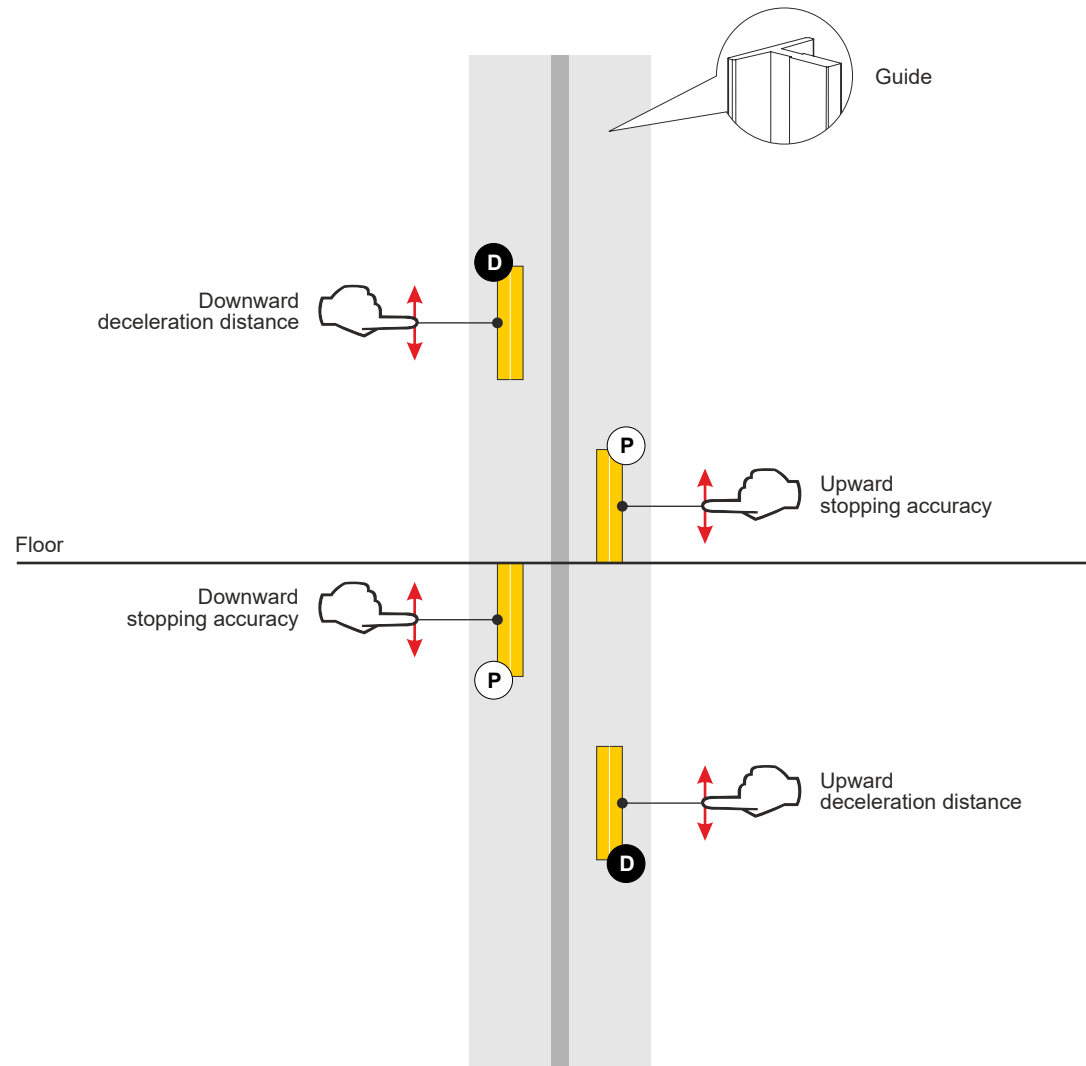

## CONNECTIVITY (FUSION APP)

### FUSION Dashboard

Before even seeing how to connect and interact with the installed device, you need to access the Fusion Dashboard cloud software.  
<https://fusiondashboard.dmg.it/>



On the Fusion Dashboard cloud, register the company, buildings, devices and operational technicians, as indicated in the video tutorials on the DMG DIDO site on the "Connectivity and Fusion app" page.  
<https://dido.dmg.it/knowledge-base/connectivity-fusion-app/>

### Connection mode

W-Fi connectivity to smartphones comes as a standard for all Junior 4.0 controllers, at no extra costs. To enable connectivity and benefits from the advantage of real-time monitoring of the lift, two solutions are available:

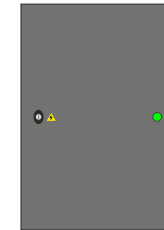

#### LOCAL connections

The local connection carry out on the installation site of the Pitagora system, via Wi-Fi HotSpot located in the TOC board and in the Junior 4.0.  
 Before connecting locally to the TOC and Playpad 4.0 devices via the Fusion app (described below), it is necessary to check that the Wi-Fi signal is enabled on these 2 devices.



| MENU Main Menu |               |
|----------------|---------------|
| 1              | Emulation     |
| 2              | Status        |
| 3              | Configuration |
| 4              | USB           |
| 5              | Peripherals   |
| 6              | Info          |

| NET Network configuration |                   |
|---------------------------|-------------------|
| 1                         | WiFi Access Point |
| 2                         | WiFi Remote       |



#### REMOTE connections

The remote connection allows you to access the devices connected via Telemaco II 4G modem.  
 Telemaco II 4G is supplied without a SIM; the choice of the SIM is at discretion of the customer.  
 Instructions for installing the Telemaco II 4G modem:  
<https://dido.dmg.it/knowledge-base/telemaco-modem-4g-new/>



Telemaco II 4G modem

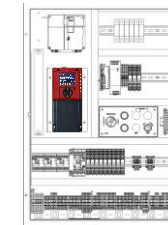

Junior 4.0

### Lift controller management via the Fusion app



Fusion is the application (IOS / Android) created by DMG for the direct management of compatible installed devices.

Download the Fusion app using the QR code on the side.



1



Start the FUSION app and login when the smartphone is still connected to internet.

You can reach devices locally without logging in (Select "Local Connection").

2



Select the type of device to manage.

3

#### Local connection

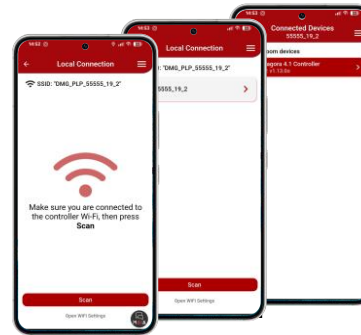

Make sure you are connected to the controller's Wi-Fi network:

- In the network settings of the smartphone, search and select the Wi-Fi network of the device to connect to (Playpad / TOC):
- DMG\_PLP\_xxx > PLAYPAD
- DMG\_TOC\_xxx > TOC

The login credentials are provided by DMG together with the documentation supplied with the product. Finally search for devices (press "Scan") and select the device to manage.

| WiFi PLAYPAD |                                 |
|--------------|---------------------------------|
|              | WiFi SSID<br>DMG_PLP_11776_22_1 |
|              | WiFi Key<br>xjyn\$VzRoe         |
| WiFi TOC     |                                 |
|              | WiFi SSID<br>DMG_TOC_11776_22_1 |
|              | WiFi Key<br>gh:p2e&_1           |

4

#### Remote connection

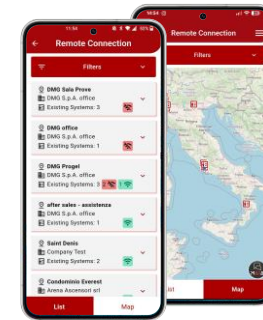

You can now choose the device to manage from either a device list or a device map.



## TEST AND MEASUREMENTS

**! MAIN PROTECTION SWITCH** OFF ON

The main switch of the controller must be switched off at every maintenance and at least 365 days after the last switch off and on.

To access the TESTS AND MEASUREMENTS section on the Playpad, set the display as indicated.



- MENU Main Menu
- 1 Emulation
- 2 Status
- 3 Configuration
- 4 USB
- 5 Peripherals
- 6 Info

**EMU Emulation**

- PLAYBOARD 4.0 -  
DMG S.p.A.  
S/N 12345\_19\_3  
3.3.7 r [EFBEADDE]



## FINAL LIMIT SWITCH TEST



This test is only used to check the functionality and position of the final limit switch; this test does not check the behaviour of the car after leaving the final limit switch.

- 1 TOP floor
- 2 **Final limit switch (IN)**
- 3 **Final limit switch (OUT)**
- 4
- 5 **OK (Reset Fault)**
- 6 Repeat 1 ÷ 5 but at the BOTTOM floor

## RE-LEVELLING TEST

- 1
- 2
- 3
- 4 Repeat 1 ÷ 3 at every floor

### BALANCING SYSTEM MEASUREMENT

**1** BOTTOM floor

**2** **EMU Emulation**  
Floor 0 12:30:56  
<Configuration>  
test  
**TEST 9**

**3** **EMU Emulation**  
Floor 0 12:30:56  
<Configuration>  
test  
^ 8,50A v 8,20A

Value of the current absorption of the motor, measured at half travel distance

**BALANCED CAR**  
Typically 50% capacity  
See the installation booklet

### DYNAMIC BRAKE TEST

**1** TOP floor  
 125% CAPACITY

**2** **EMU Emulation**  
Floor 2 12:30:56  
<Configuration>  
test  
**TEST 4**

**3** STOP

**4** **EMU Emulation**  
Floor 2 12:30:56  
<Configuration>  
test  
-123 mm 0,50 s

### MOTOR RUN TIME TEST

**1** BOTTOM floor

**2** **EMU Emulation**  
Floor 0 12:30:56  
<Configuration>  
Test  
**TEST 8**

**3** **EMU Emulation**  
Floor 0 12:30:56  
<Faults>  
Faults: 1  
Running UP time  
**DEF**

"DEF" ON

**EMU Emulation**  
Floor 0 12:30:56  
<Faults>  
Faults: 1  
Reset ?  
**DEF**

OK (Reset fault)

$V = 0 \text{ m/s}$

## ROPES CREEP TEST

## OVERSPEED GOVERNOR TEST

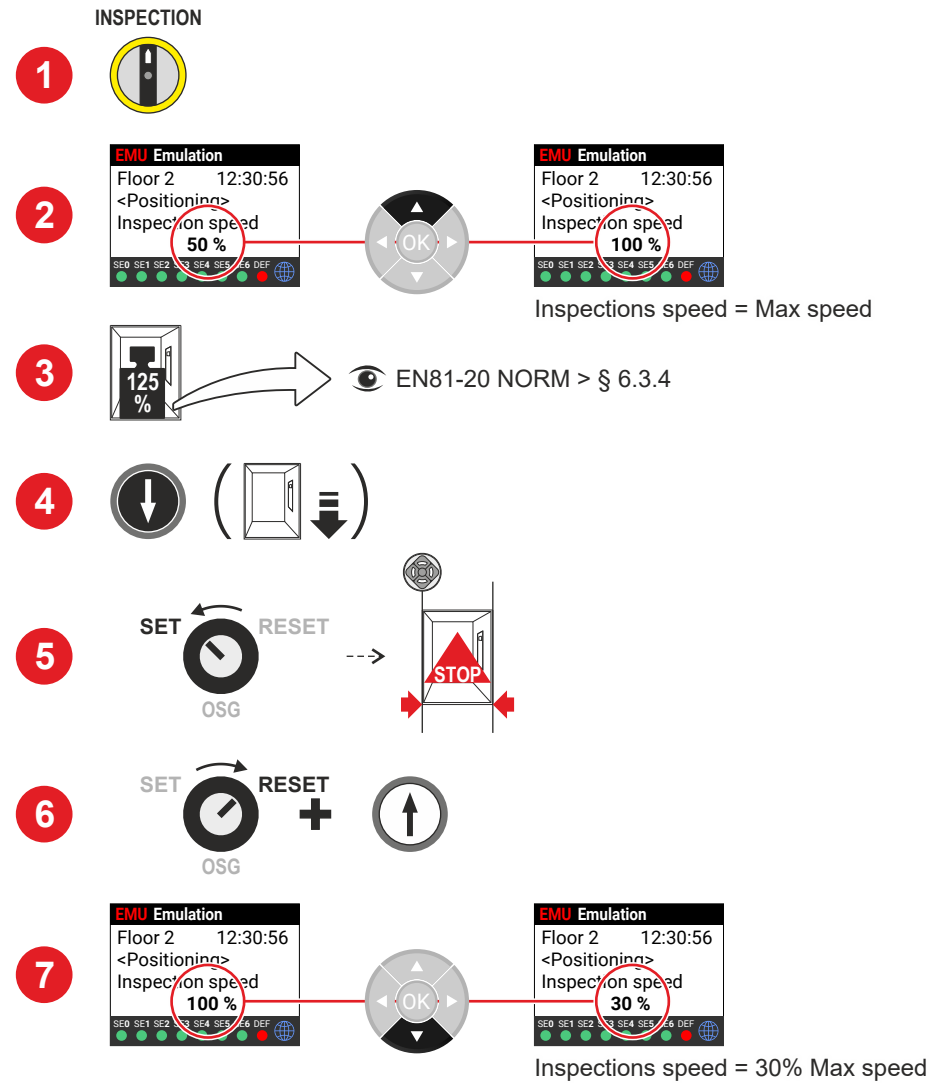
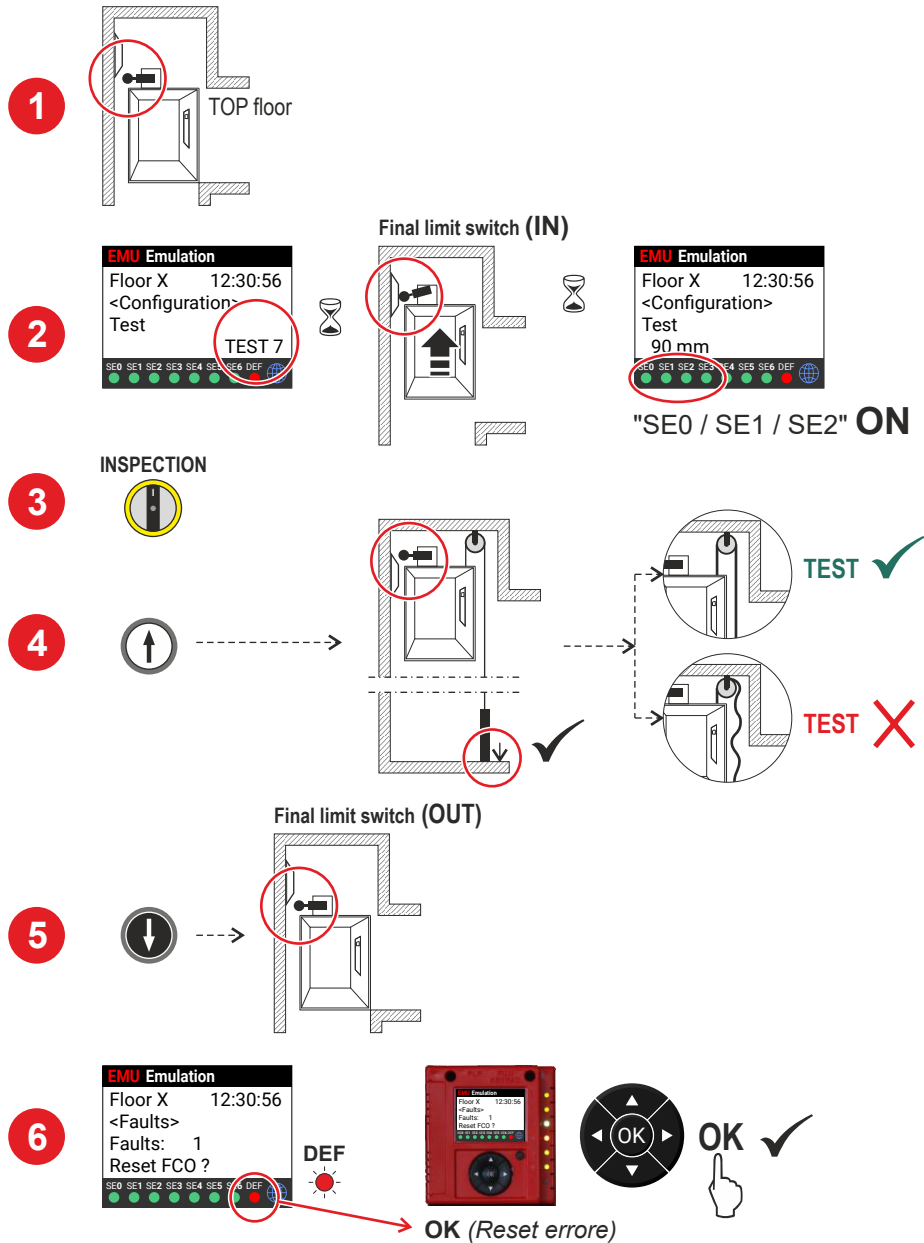

## BASIC TROUBLESHOOTING

Follow this first-level procedure to detect and remove the most common faults:

### 1 Check Diagnostic LEDs (VVVF unit)



|       |                    |   |
|-------|--------------------|---|
| LED 1 | LED1 (Green led):  | NOT used  |
| LED 2 | LED2 (Green led):  | CAN Cabin termination active: led switch off when an optional board (PIT8 / 16IO / 16RL) is connected to the controller (termination automatically moves on last optional board). |
| LED 3 | LED3 (RGB led):    | System status Led (see table):  |
|       | <u>Led Color</u>   | <u>Status</u>   |
|       | Led Off            | The system is performing the reset procedure  |
|       | Green              | The system is in normal operation mode  |
|       | Yellow             | The system is in inspection mode  |
|       | Pink               | The system is in temporary operations mode  |
|       | Purple             | The system is out of service (parking of cabin)   |
|       | Cyan               | The system is running in priority mode (LOP / CAR)  |
|       | Red                | The system is operating in Fire-fighters mode   |
|       | White              | The system is performing the emergency procedure  |
|       | Blue               | The system is performing the elevator car drift control procedure   |
| LED 4 | LED4 (Yellow led): | Led blinks when board is running.   |
| LED 5 | LED5 (Green led):  | Led on gives the status of SE5 safety chain   |
| LED 6 | LED6 (Green led):  | Led on indicates the presence of the lift car in the door zone area.  |
| LED 7 | LED7 (Red led):    |   |
|       | Led Off            | No fault active   |
|       | Led Flashing       | One (or more) fault active  |
|       | Led On             | Locking fault active  |

### 2 Read error messages on the PlayPad error menu / Fusion error page

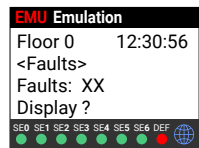
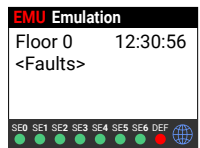

- Error X of XX total.
- **Code/description error.**
- Car position when the fault was detected.
- Number of repetitions of the same error.
- Additional code.
- Date and time of last detection.
- (\*) If the error is still active.

This Menu lists the last faults stored into the internal memory of the controller. All faults are described in the **Troubleshooting guide**. See leaflet on the back of this guide.

**WARNING:** In case of black out, the internal memory is saved only if the battery is connected.

### 3 If the car is blocked with people inside

Perform the RESCUE OPERATION as shown on the following page ----- >>>

## RESCUE OPERATION FOR TRACTION LIFTS

IF THE CAR IS BLOCKED ----->



After pressing the ZP button (door zone) you have 1 hour (default) to carry out the maneuver. If the procedure takes longer, press it again.

1

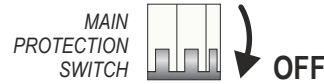

2

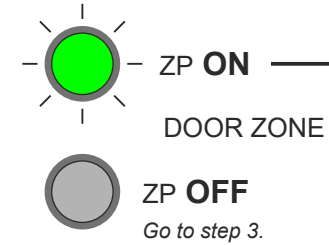
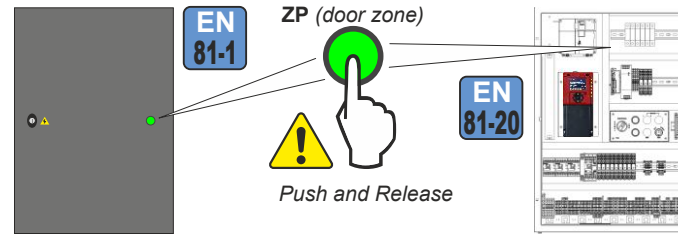

3

Open the brake using the special lever on the winch and at the same time turn the handwheel in the direction of easier movement or less effort. Move the car until reaching the first useful floor (green light on).

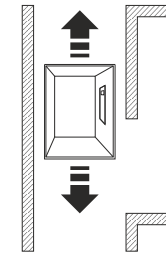

4



Stop the elevator maneuver when the green ZP warning light comes on.

5



6

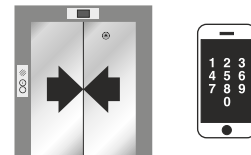

During and after the manual maneuver, make sure that all the landing doors are closed and locked and inform the maintenance company. If the system is to remain out of service for more than 14 hours, move the car to the lowest floor.

# ADVANCED SETTINGS



**1 Defining the position of the main floor**

**2 Setting date / time**

Da = Day  
Mo = Month  
Yr = Year  
D = Weekday (1=Mon)  
Hr = Hours  
Mn = Minutes

**3 Defining a protected floor**

**4 Changing door assignment / layout**

**5 Adjusting door parameters**

- All calls below this floor are served only upwards (only down collective).
- Lift not in use goes to Main Floor after xx seconds (this parameter can be set in the menu "Special features > Automatic return")

*If a protected floor is programmed, when the elevator car reaches the floor, the door does not open, instead the monitor will show images coming from the camera corresponding to that floor. Doors can be opened only by pressing the OPEN DOOR button; if this does not happen, the lift moves to the previous floor and then stops the protected floor mode (this operating mode is only possible with DMG's monitoring system).*

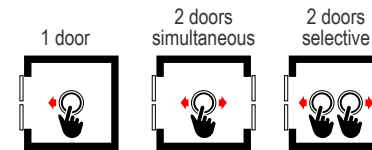

- Manual doors at floors / car doors manual or not present.
- Manual doors at floors / car doors independent.
- Manual doors at floors / car doors automatic.
- Automatic doors at floors and in the car.

- In the "Doors" menu it is possible to manage other parameters such as:*
- Time before activation of the retiring ramp and the lock fault
  - Time before door opening
  - Life car parking time with open doors
  - Time before door closes in case of registered calls
  - Many other settings



**DMG SpA** • Via delle Monachelle, 84/C • 00071 POMEZIA (ROMA) - ITALIA  
Tel. +39 06930251 • [www.dmg.it](http://www.dmg.it)